

**AXOR**<sup>®</sup>

AXOR

**KOMFORT LINE K-3**

Smart&Quick

Window hardware for PVC profiles



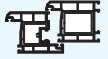

## Content

---

	General product information
1	Hinges
2	Gears
3	Corner transmissions / Middle locks
4	Stay arm
5	Additional elements
6	Hardware set combinations
7	Installation tools
8	Profile-dependent elements

## System KOMFORT LINE K-3 SMART&QUICK

General product information

### System KOMFORT LINE K-3 SMART&QUICK

**SMART&QUICK** is an updated KOMFORT LINE K-3 window hardware system of AXOR INDUSTRY company.

AXOR design engineers set themselves the goal of improving this line of hardware and making it even more versatile and convenient to use. As a result, we got the updated Komfort Line K-3, which provides even higher assembly speed, but completely preserves its basic characteristics: comfortable operation, high quality and safety for end users.

The main advantages of updated **K-3 SMART&QUICK**:

- The changed face plate provides a higher rigidity of the profile section, which increased its bending resistance, and the flawless appearance will satisfy even the most demanding consumers;
- The increased linear dimensions of gears and stay arm allow PVC window producers use cutting tools (punching machines) for both straight and eccentric cuts when installing hardware;
- Better connection of gears and stay arm with corner transmission due to location of the driving rod 0.25 mm lower;
- Locking pins are located 0.25 mm lower, which will improve the operation of hardware set with micro ventilation and safety locking plates;
- The presence of corner transmissions for eccentric cut will significantly facilitate the work of PVC window producers.



**SMART&QUICK** is the constant quality of AXOR Industry products, speed of assembly and versatility in using.

#### Application range

All window furniture in our catalogue is intended exclusively for the internal opening of windows and balcony doors.

The system K3 has been provided in such assemblies as, tilt and turn opening, single turn opening, single tilt opening and double sash opening as well.

#### Hardware elements

All sets of hardware, which were indicated in this catalogue, must consist only from original elements of AXOR INDUSTRY. Otherwise the producer won't be able to guarantee the work of hardware properly.

So, for each type of a sash, it is possible to set optional elements for additional functionality of one. These elements were marked with following colors:

**Red** – base safety;

**Grey** – possible equipment.

#### Quality

All products of AXOR INDUSTRY corresponds according to technical norms of DSTU Б B.2.6-39:2008, EN 13126-8 which regulate the main requirements of tilt and turn hardware.

#### Assembly

So, for accurate an assembly and for further correct work of hardware it is necessary to follow instructions of this catalogue.

Fixing of details:

The handle with screws M5 x 40mm.

The elements of a sash and the locking plates: self-tapping window chromated screws 4,0 x 25 mm or 3,9 x 26 mm.

The elements of hinges group: galvanized or alternatively chromated screws with flat head and cross-shaped slot, DIN 7982 3,9 x 32 mm or 3,9 x 38 mm.

Preliminary drilling is necessarily for these screws. Perforation instead of drilling is forbidden. Drill diameter for PVC profiles is 0,7, and for steel profiles is 0,8 diameter of a screw.

Settings of electric- or pneumatic screwdriver: maximum torque is 2.5 Nm, rotation speed: max 600 - 1000 rpm.

**In case of non-compliance of these catalogue's recommendations for assembly and exploitation, the producer AXOR INDUSTRY cannot guarantee properly work of separate elements, as well as, the work of hardware system in whole.**

**The AXOR INDUSTRY Company reserves the right, in a process of further an improvement and development, to make technical changes of product KOMFORT LINE K-3, and also to change packaging norms.**

## Locking pins

General product information

### Locking pins

The system of window hardware KOMFORT LINE K-3 SMART&QUICK was equipped with cylindrical pins of sliding.

Thus, as additional option it is possible to complement elements of a sash with a mushroom pin, to conform the base safety level according to AhS Standard.

In order to ensure air and water permeability of window and balcony door units in accordance with the DSTU Б B.2.6-39:2008 standards, the construction of turn, tilt and tilt&turn devices shall ensure that the contact between the sash (leaf) and the frame remains tight and even for the entire duration of service life, based on recommendations from the profile system manufacturers, the use of a certain type of gasket and observance of the required size of gap under the gasket, which means that when assembling a tilt-and-turn (turn) window, the manufacturer must receive recommendations regarding the number of and the distance between the locking points directly from the profile manufacturer, in writing and with the explanation of these requirements.

The adjustment range of locking pins is +/-1 mm. The diameter of pins is 11 mm.

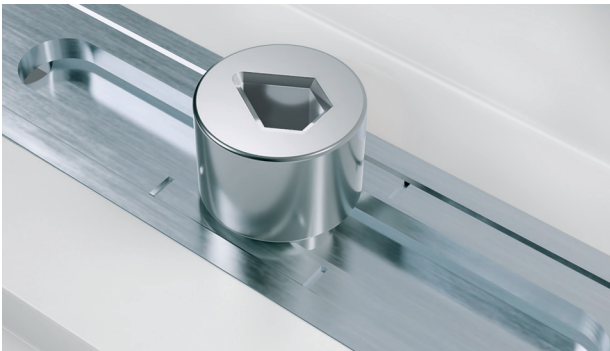

### Technical features

There is an opportunity to fix the finger of the corner bearing at the extreme bottom position under angle 180° in order to make an assembly more comfortable by a screw gun, so the finger is not falling down and hindering to screw the screws.

3) The holes of the corner bearing and stay arm bearing were designed thus all screws to pass through reinforcement profile inside of a frame.

4) The drill-in corner hinge has two pins following sizes: length 5 mm and diameter 3 mm to fix reliably this one before the moment of screwing by screws.

5) There is a plastic bush, of high-strength polymer, inside of the drill-in corner hinge, which prevents unscrewing of an adjustable screw during the turning of a sash. Thus there is not any creak during of the turning of a sash. The adjustable screw of the drill-in corner hinge was fixed primordially in the central position to exclude unscrewing during transportation and exploitation of end product.

6) The finger of the stay arm bearing gets the hard and reliable fixation thanks to a special bush of high-strength polymer, excluding the disconnection by itself.

7) The anti-theft locking plates with mushroom pins of the corner transmission and middle lock together allow equipping a window

according to requirements of the base safety according to AhS Standard.

8) The wrong operation safety device with sash lifter is universal for left and right opening. There is a fixation of the central position before a moment of assembly. It can work even the gap between the frame rebate and sash rebate is from 10,5 till 14 mm. Thus, if it is necessary there is an opportunity to adjust a lifting plate at +/- 1 mm by height. So, the setting of the lifting plate with a special telescopic jig provides the correct work this wrong operation safety device whole.

9) The bottom extension has "a ski-lift" which was integrated to this one, thus it excludes the sagging down of a sash when it is closed.

10) The junction of the middle lock to the stay arm is quite reliably thanks to a screw, which joins these ones.

11) The adjustment range of the stay arm by a gasket pressing is +/- 1 mm.

12) There are five types of middle locks thus, it is quite useful for an optimization of a warehouse and for logistics too.



### The protective plating of KOMFORT LINE K-3 SMART & QUICK

The quality of the plating of all hardware's elements affects at the work of accessories, durability and surface appearance very much.

Thus, the special technology of galvanizing allows getting the high-quality plating, which provides all elements of KOMFORT LINE K-3 required level of protect against corrosion.

Nevertheless, a silver color of the hardware's surface appearance fulfills a decorative function to allow it to combine successfully with the others elements of a window.



### The causes to appear the corrosion at hardware's surface.

- 1) The prolonged exposure of high wetness (more than 70%).
- 2) The polluted air with gas, comprising a connection of various acids, and an exposure of salt-mist.
- 3) The mechanical damages of surface during an assembly or maintenance, which disrupt wholeness of the plating.
- 4) Some cleaning agents include alkali, acid and so on.
- 5) Under the influence of different temperature there can appear the formation of condensate at the surface of hardware.
- 6) The pollution with some building materials, in particular by cement or gypsum plaster.

### Some instructions to keep the quality of surface plating

- 1) Avoid hits of building materials at the hardware surface, for example plaster, cement, different building solutes and building dust.
- 2) Avoid any exposure of aggressive acidic steam and salt-mists at the hardware surface.
- 3) Do not use any rubber gasket, which is able to soaks up and to hold some moisture.
- 4) The cleaning should be made with pH-neutral solute, before diluted.
- 5) Do not permit any mechanical damages of the hardware's surface by building, assembly and detergent instruments.

### Storage conditions







This applies to storage and transport, as well as for unloading and loading procedures. Where appropriate, plastic protective sheets or similar are to be used during outdoor transport when raining (i.e. on-site transport). Storage may only be carried out in suitable, closed rooms and not outdoors. Condensation is to be absolutely avoided during the entire transport and storage duration.

- 1) Always keep the hardware boxes closed, and always cover up hardware boxes which were opened and do not put boxes directly on the floor.
- 2) Transport the hardware always with suitable devices (if possible on pallets with stretch film).
- 3) The components may not get wet. The packaging must remain dry (it is recommended: Warehouse temperature – 15-25°C; Relative humidity – less then 50%).
- 4) If box becomes wet please immediately unpack the components from the wet bundles, dry the components and check for signs of corrosion. In any case repack the usable components when dry with new packing material.

# Basic notations and representation of the information

General product information

## Basic notations

	Maximum sash weight, kg		Cylindrical locking pin
	Screws (quantity/size)		Mushroom locking pin
	Packaging quantity (pcs)		Locking plate for double-sash window
	Drill-bit (diameter)		



Tilt and turn sash

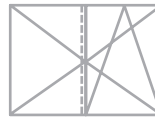

Tilt and turn double sash



Turn-only sash



Tilt-only sash



Arched tilt and turn sash



Tilt and turn sash for oblique windows



Sliding sash

## Representation of the information

All article numbers in this catalogue were afforded an alphanumeric form. The decipher of all article numbers you can find at the pages 8-9.

Thus, all sizes which were shown in that catalogue are nominal and contain general tolerances.

All sizes were conferred in mm.

The information about restriction of sashes' sizes should be taken from diagrams of this catalogue or a user's guide.



**The single sash constructions**

Sash rebate gap (A):	min. 12 mm
Sash overlap (C):	18 – 22 mm
Sash groove position (B):	9 mm

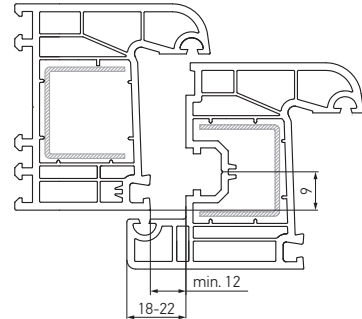

Sash rebate gap (A):	min. 12 mm
Sash overlap (C):	18 – 22 mm
Sash groove position (B):	13 mm

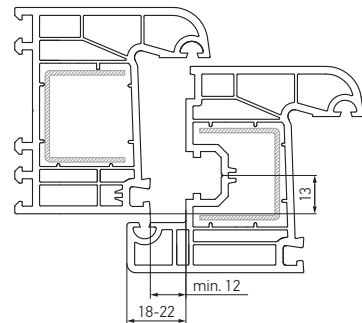

**The double sash constructions with opposite hardware groove**

Sash rebate gap (A):	min. 12 mm
Sash overlap (C):	18 – 22 mm
Sash groove position (B):	9 mm

The handling of a passive sash with double sash's gears K1002-XX-N03

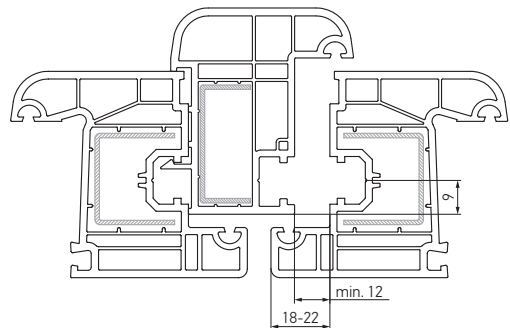

Sash rebate gap (A):	min. 12 mm
Sash overlap (C):	18 – 22 mm
Sash groove position (B):	13 mm

The handling of a passive sash with double sash's gears K1002-XX-N03

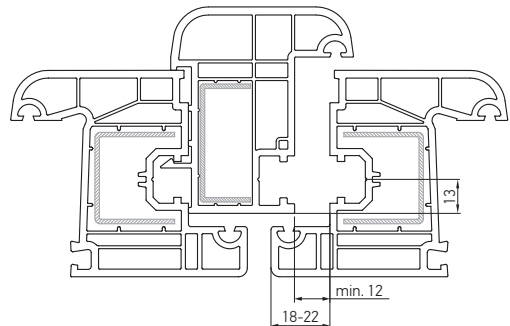

The information about profile-dependent elements you find at the profile list

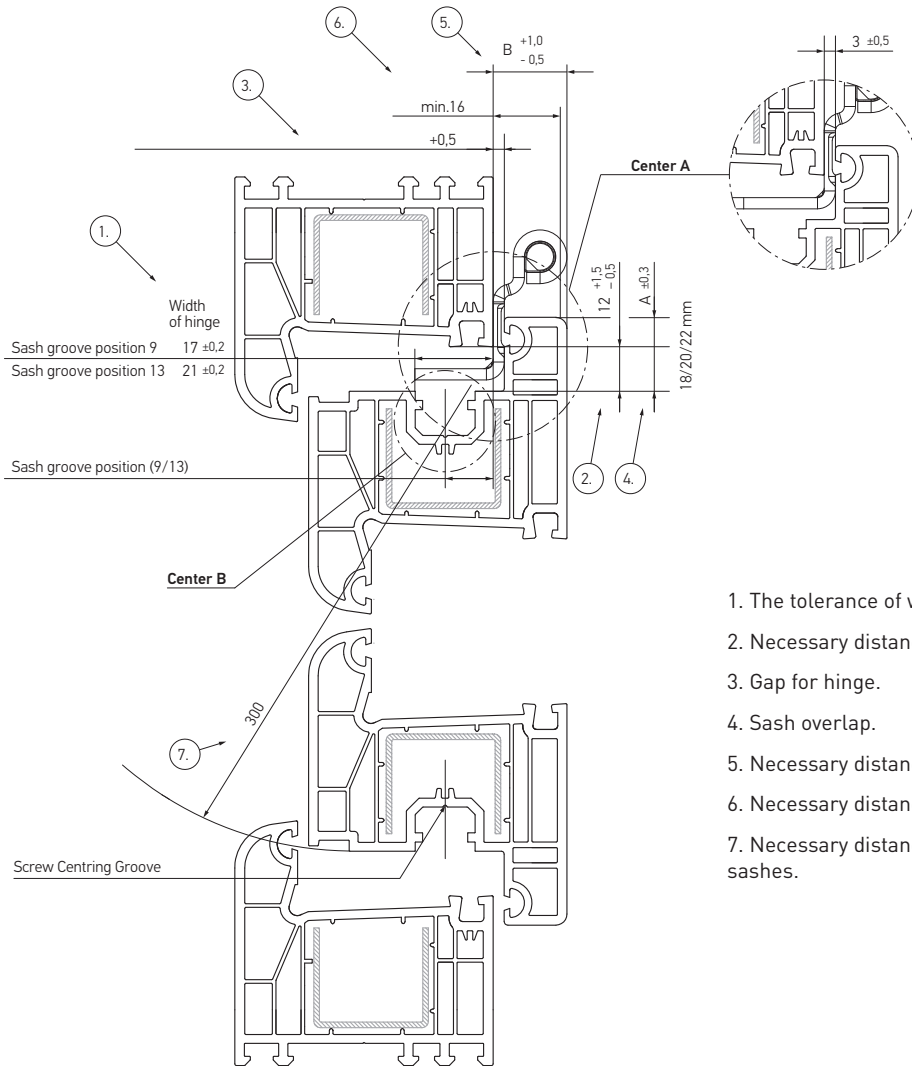

1. The tolerance of width for top sash's hinge.
2. Necessary distance for moving the hardware.
3. Gap for hinge.
4. Sash overlap.
5. Necessary distance for the clamping of gasket adjustment.
6. Necessary distance for inserting a hinge into sash overlap.
7. Necessary distance for operation of small turn and tilt-turn sashes.

Center B

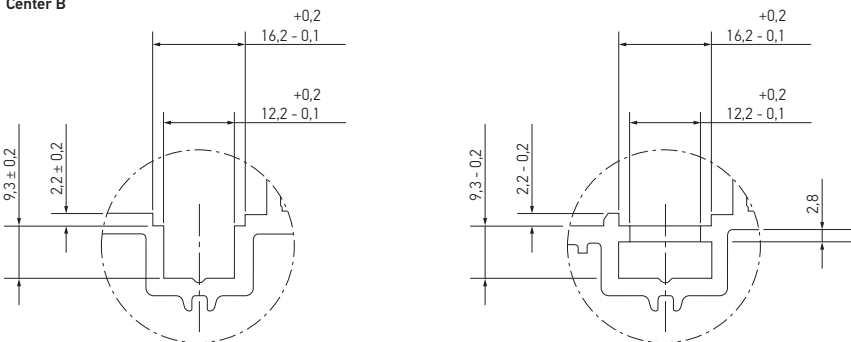

Dimensions for plastic profile according RAL as of February 1998.

Gütegemeinschaft Schlösser und Beschläge e.V.,  
Offerstr. 12, 42551 Velbert





Article structure

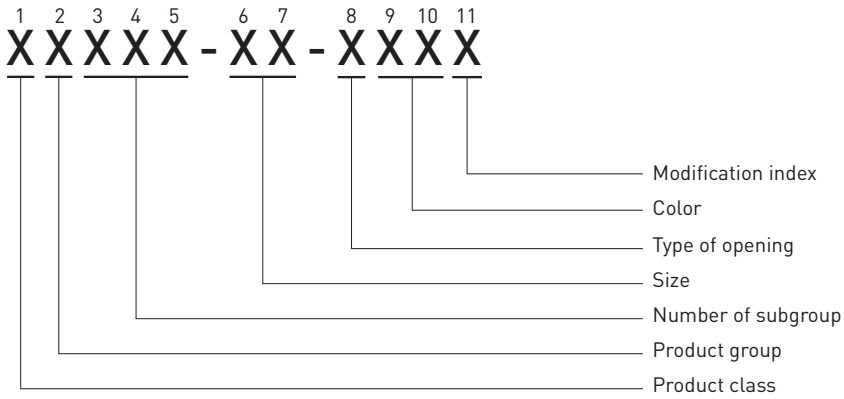

1. Product class  
(1st sign)

**X**XXXX-XX-XXXX

- "S" – smart line
- "K" – komfort line
- "A" – element refers to both classes

2. Product group  
(2nd sign)

X**X**XXX-XX-XXXX

- |                            |  |
|----------------------------|--|
| "0" – alternative value    | "6" – standart locking plates, tilt locking plates |
| "1" – gear variable        | "7" – locking plates and the other accessories     |
| "2" – corner transmissions | "8" – alternative value                            |
| "3" – stay arm             | "9" – alternative value                            |
| "4" – extensions           |  |
| "5" – hinges               |  |

3-5. Subgroup number  
(3rd, 4th, 5th sign)

Xx**XXX**-XX-XXXX

Additional information about product's subgroup.  
Example: group "gears", subgroup "double sash lever espagnolette variable".

6-7. Size  
(6th, 7th sign)

XXXXX-**XX**-XXXX

Important dimensions of the product such as the length of the axis, etc.



8. Type of opening  
(8th sign)

XXXXX-XX-**X**XXX

“N” – universal

“R” – right

“L” – left

9, 10. Color and plating  
(9th and 10th sign)

XXXXX-XX-X**XX**X

The ninth symbol indicates the color hue:

0 – basic color. For example, RAL9016 is the basic for white color, it is indicated by the code **01**; RAL8022 is the basic for brown color – **02**, etc.

1 – additional color. For example, RAL8019 for brown color – **12**.

2...9 – following additional colors.

0 – plating

4 – champagne

8 – steel surface

1 – white

5 – gold

9 – special colors

2 – brown

6 – bronze

3 – silver

7 – black

By default, all surfaces are glossy and this is not indicated separately in the article. Matte surfaces are marked with the letter **M** after the 10th symbol.

11. Modification index (A, B, C)  
(11th sign)



# Application range diagrams

General product information

## Tilt and turn

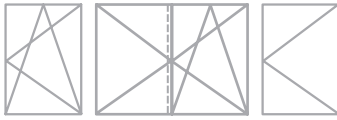

Valid sash's size  
Permissible sash's weight for this range is 130 kg max.  
1 mm / m<sup>2</sup> glass thickness = 2.5

### Allowable sash dimensions

Allowable sash weight for this range 100 kg  
1mm/m<sup>2</sup> glass thickness= 2.5kg

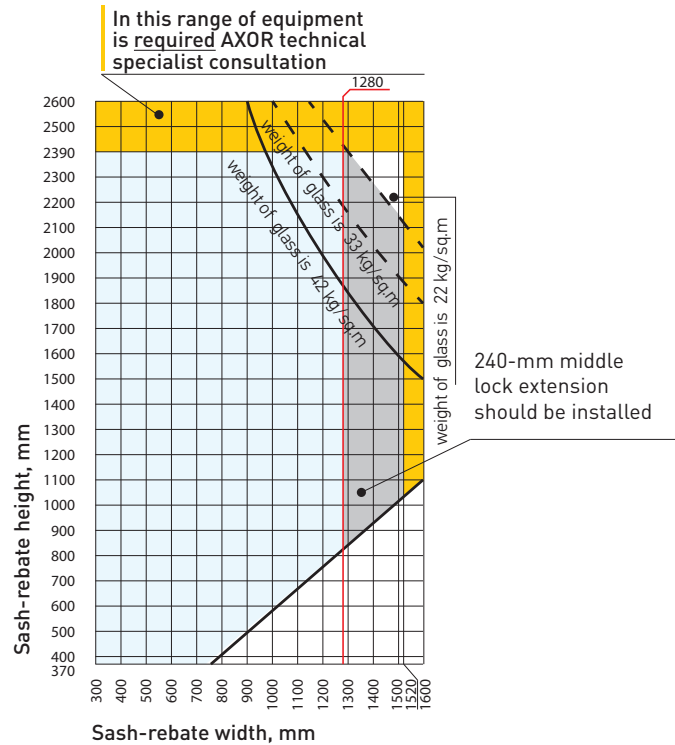
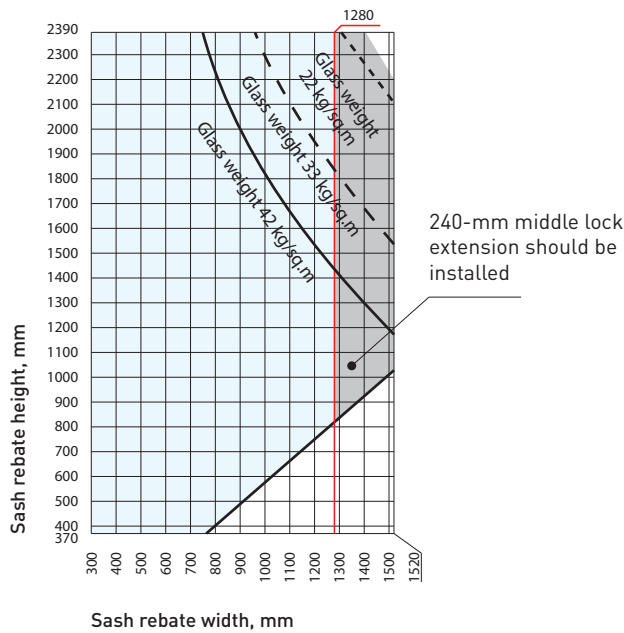

## Tilt sash



Sash dimensions limits  
Maximum sash weight is 50 kg

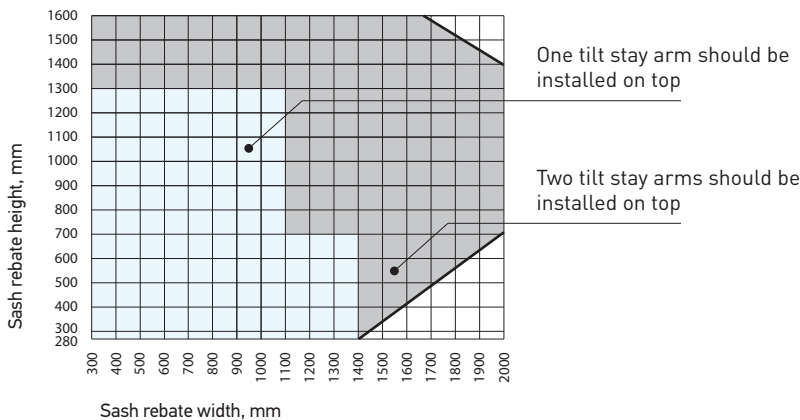

Safety conventional symbols

Conventional symbol	Meaning
	<p><b>Danger of injury through trapping of body parts</b></p> <ul style="list-style-type: none"> <li>• Never reach into the opening between the sash and the outer frame when closing windows/doors.</li> </ul>
	<p><b>Risk of injury from falling through open windows</b></p> <ul style="list-style-type: none"> <li>• Always use stable step ladders.</li> <li>• Protect yourself against falling out of windows.</li> <li>• Do not steady yourself or hold on to the opened sash.</li> </ul>
	<p><b>Risk of injury or damage from pressing the sash against the reveal</b></p> <ul style="list-style-type: none"> <li>• Do not press the sash against the window reveal.</li> </ul>
	<p><b>Risk of injury from trapping parts of the body between the sash and the frame</b></p> <ul style="list-style-type: none"> <li>• Do not insert obstructions into the opening between sash and frame.</li> </ul>
	<p><b>Risk of injury and material damage from overloading the sash</b></p> <ul style="list-style-type: none"> <li>• Do not overload the sash.</li> </ul>
	<p><b>Risk of injury from the effect of wind</b></p> <ul style="list-style-type: none"> <li>• Prevent wind from acting on the open sash.</li> <li>• During wind/drafts, close and lock windows.</li> </ul>

# Certificates

## General product information

### Certificate ISO 9001:2015

## Certificate

Standard **ISO 9001:2015**  
 Certificate Registr. No. **01 100 1519050**

**Certificate Holder:**   
**AXOR INDUSTRY**  
 Limited Liability Company  
 Truda av. 32  
 49041 Dnipro  
 Ukraine

**Scope:** Manufacture and supply of turn, tilt and tilt & turn hardware for windows and balcony doors.

Proof has been furnished by means of an audit that the requirements of ISO 9001:2015 are met.

**Validity:** The certificate is valid from 2021-03-31 until 2024-03-30.

2021-03-31

TÜV Rheinland Cert GmbH  
 Am Grauen Stein • 51105 Köln

www.tuv.com

### Certificate QM 328

## Zertifikat / Certificate

Zertifikatsnr. / Certificate No.: 228-9003481-1-8

**Dreh- und Drehkippbeschläge für Fenster und Fenstertüren**  
 Turn and tilt-turn hardware for windows and casement doors

**Produkt**  
 max. Flächgewicht 130 kg  
 max. Gesamtgewicht

**Einsatzbereich**  
 Systeme mit entsprechender Beschlagsaufnahme  
 Systems with suitable hardware groove

**Hersteller**  
 AXOR Industry  
 1, Sobinova Str., UA 49083 Dnepropetrovsk

**Produktionsstandort**  
 AXOR Industry  
 1, Sobinova Str., UA 49083 Dnepropetrovsk

**Grundlagen**  
 EN 1191  
 EN 12400  
 Klasse 2  
 EN ISO 9227  
 EN 1670  
 Klasse 5  
 class 5

**Dauerfunktion**  
 (QM 328)  
 Ausgabe / Issue: 2018

**Korrosionsschutz**  
 corrosion protection

Mit diesem Zertifikat wird bescheinigt, dass das benannte Bauelement den Anforderungen des zugrundeliegenden IQM-Zertifizierungsprogramms in der aktuellen Fassung entspricht.

This certificate attests that the building product mentioned fulfills the requirements of the underlying IQM-certification scheme in its current version.

Die Fertigstellung von Produktfamilien des aufgeführten Bauelementes und Entsprichtung durch eine akkreditierte Prüfstelle nach EN ISO 9001:2015 unter Berücksichtigung der Anwendungsbedingungen.

Implementation and maintenance of a factory production control by the manufacturer.

Erstellung und Aufrechterhaltung einer werkseigenen Produktionskontrolle durch den Hersteller.

Initial inspection of the production site and the factory production control by IFT.

Entspricht dem Wesen und der werkeigenen Produktionskontrolle durch IQM-Zert.

Continuous third-party control of the production site and the factory production control by IQM-Zert.

Dieses Zertifikat wurde erstmals am 21.05.2014 ausgestellt und gilt 3 Jahre, wenn sich zwischenzeitlich die Festlegungen in der oben angeführten technischen Spezifikation oder der Herstellerbedingungen im IQM oder in der werkseigenen Produktionskontrolle selbst nicht wesentlich verändert haben.

This certificate was first issued on 21.05.2014 and will remain valid for 3 years, as long as neither the conditions listed down in the technical specification listed above, nor the manufacturing conditions in the production site nor the factory production control itself are modified significantly.

Das Zertifikat darf nur verwendet werden, wenn alle Änderungen der Voraussetzungen für die Zertifizierung und dem IQM-Zert mit den erforderlichen Nachweisen unverzüglich mitgeteilt werden.

The reproduction of the certificate without any change from the original is permitted. Any changes to the pre-qualified certificate in conformity with the necessary evidence.

Das Unternehmen ist berechtigt, das benannte Bauelement gemäß der IQM-Zertifizierung und dem IQM-Zert für die Verwendung zu kennzeichnen.

The company is authorized to affix the "ift-certified" mark to the building product mentioned according to the rules for use of the "ift-certified" mark.

Dieses Zertifikat enthält 2 Anhänge.

This certificate contains 2 annexes.

ift Rosenheim  
04.10.2019

Christian Kehler  
 Leiter der IQM-Zertifizierung und Dokumentation  
 Head of IQM-Certification and Documentation

Gültig bis / Valid until: 20.05.2024

Prof. Dr. Udo Kasper  
 Institut für Bauprodukte  
 Director of Institute

228-9003481

ift ZERTIFIZIERT

### Corrosion resistance test report EN 1670:2007

## Nachweis

Korrosionsbeständigkeit gemäß EN 1670 : 2007 + AC:2008

**Prüfbericht**  
 Nr. 13-000677-PR02  
 (PB-G05-03-de-01)

**Auftraggeber**  
 AXOR Industry  
 1, Sobinova Str.  
 49083 Dnepropetrovsk  
 Ukraine

**Produkt**  
 Drehkippbeschlag für Fenster

**Bezeichnung**  
 Einzelteile gemäß Typenliste

**Leistungsrelevante Produkteigenschaften**  
 Material: Stahl mit verzinkter Oberfläche

**Besonderheiten**  
 keine

**Ergebnis**  
 Klassifizierung gemäß EN 1670 : 2007 + AC:2008

Klasse 5

Stahl mit verzinkter Oberfläche

ift Rosenheim  
03.02.2014

Alexander Sauer, Dipl.-Ing. (FH)  
 Produktingenieur  
 Stahlbau

Gregor Steiner  
 Laborleitung  
 Stahlbau

**Grundlagen**  
 EN 1670 : 2007 + AC:2008

**Prüfnormen**  
 ISO 9227 : 2008

**Entsprechende nationale Festlegungen (z.B. DIN EN)**  
 Darstellung

**Verwendungshinweise**  
 Dieser Prüfbericht dient zum Nachweis der Korrosionsbeständigkeit nach EN 1670 : 2007 + AC:2008

**Gültigkeit**  
 Die genannten Daten und Einzelergebnisse beziehen sich ausschließlich auf die genau für beschriebenen Prüfbedingungen. Die Klassifizierung gilt so lange das Produkt unverändert ist und die o.g. Grundlagen sich nicht geändert haben. Das Ergebnis kann unter Beachtung entsprechender Festlegungen der Produktnorm in Eigenverantwortung des Herstellers übertragen werden. Diese Prüfungsbewertung ermöglicht keine Aussagen über weitere Leistungs- und qualitätsbestimmende Eigenschaften des vorliegenden Konstruktion, insbesondere Mängel- und Abmurrungsrisse wurden nicht berücksichtigt.

**Veröffentlichungshinweise**  
 Es gilt das (R-)Markblatt "Verwendung und Prüfsituationen". Das Druckblatt mit Typenliste kann als Kurzfassung verwendet werden.

**Der Nachweis umfasst insgesamt 20 Seiten.**

ift ZERTIFIZIERT

12

**AXOR**<sup>®</sup>

**KOMFORT LINE K-3**  
Smart&Quick

Hinges

AXOR



**Corner bearing**

Hinges

**Corner bearing 3x3**

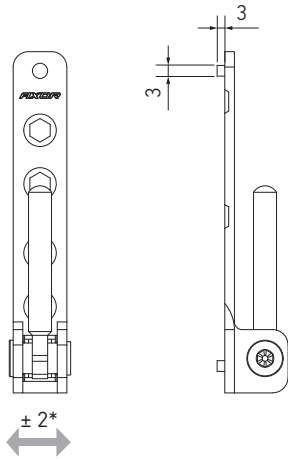

- maximum tilting of pin inclination - 180 deg.;
- for appropriate sash hinge look at p. 15;
- for decorative covers in other colors look at p. 27.

\* horizontal adjustment, mm

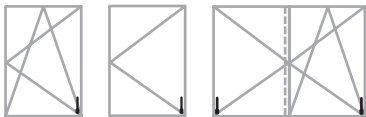

**Covers of corner bearing**

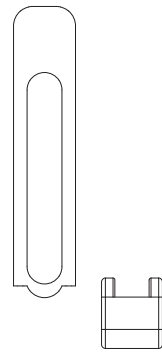

Sash overlap	Size "A"
18	18,5
20	20,5
21	21,5

The groove for glazing bead

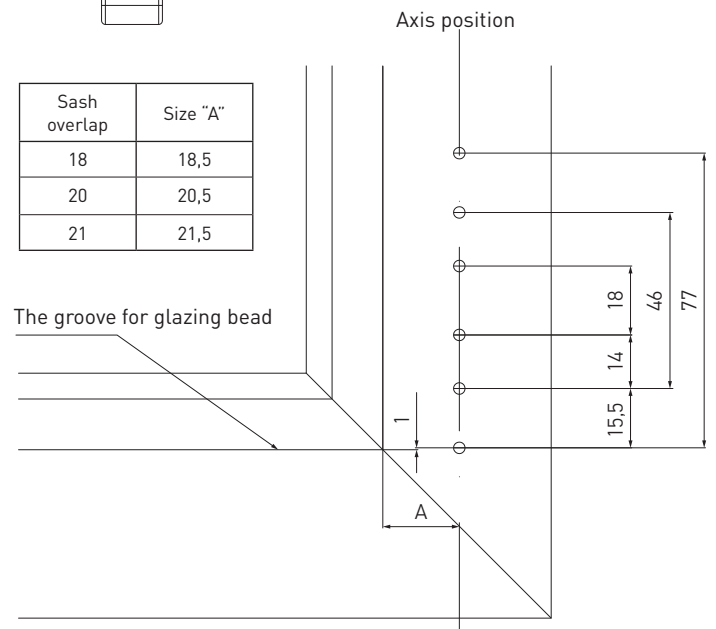

Description	Side opening	A	C	B	kg			Part No.
Corner bearing 3x3	L/R	12	—	—	100	4 / 3,9x40*	250	A5002-00-N03
Description	Side opening	A	C	B	kg			Part No.
Drilling jig for frame hinges	L/R	12	20	—	—	Ø3	50	A7002-00-N09
Drilling jig for frame hinges	L/R	12	21	—	—	Ø3	50	A7002-20-N09
Description	Side opening	A	C	B	kg			Part No.
Bottom cover of corner bearing	L/R	—	—	—	—	—	500	A7007-10-N**
Top cover of corner bearing	L/R	—	—	—	—	—	500	A7008-10-N**

A - sash rebate gap / C - sash overlap / B - sash groove position

\* - quantity/size

\*\* - for decorative covers in other colors look at p. 27



# Corner bearing

## Hinges

### Corner bearing 6x22

### Covers of corner bearing

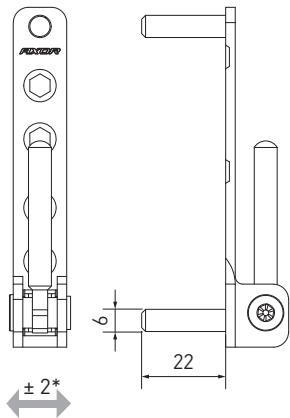

- maximum tilting of pin inclination - 180 deg.;
- for appropriate sash hinge look at p. 17;
- for decorative covers in other colors look at p. 27.

\* horizontal adjustment, mm

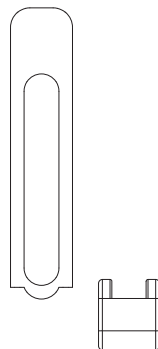

Sash overlap	Size "A"
18	18,5
20	20,5
21	21,5

The groove for glazing bead

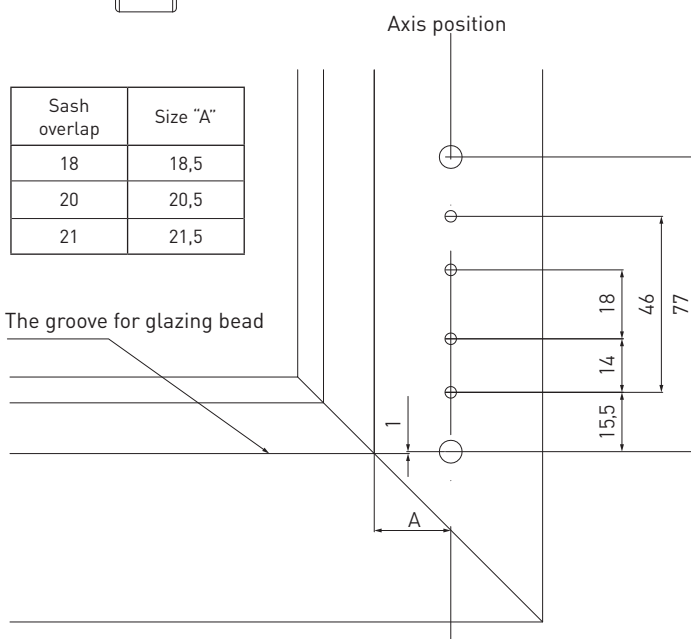

Description	Side opening	A	C	B	kg			Part No.
Corner bearing 6x22 130 kg	L/R	12	—	—	130	4 / 3,9x40	250	A5004-00-N03
Description	Side opening	A	C	B	kg			Part No.
Drilling jig for frame hinges	L/R	12	20	—	—	Ø3/6	50	A7002-10-N09
Drilling jig for frame hinges	L/R	12	21	—	—	Ø3/6	50	A7002-30-N09
Description	Side opening	A	C	B	kg			Part No.
Bottom cover of corner bearing	L/R	—	—	—	—	—	500	A7007-10-N**
Top cover of corner bearing	L/R	—	—	—	—	—	500	A7008-10-N**

A - sash rebate gap / C - sash overlap / B - sash groove position  
 \*\* - for decorative covers in other colors look at p. 27





**Corner bearing**

Hinges

Corner bearing, 100 kg,  
with installation on mullion

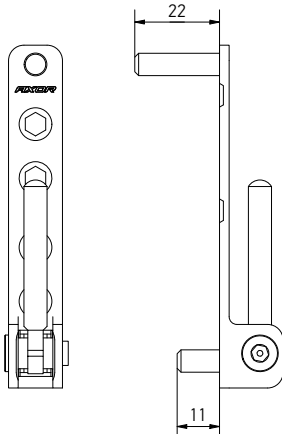

- maximum tilting of pin inclination - 180 deg.;
- for appropriate sash hinge look at p. 18;
- or decorative covers in other colors look at p. 27.

\* horizontal adjustment, mm

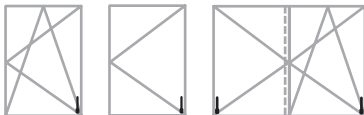

Covers of corner bearing

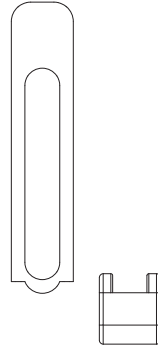

Sash overlap	Size "A"
18	18,5
20	20,5
21	21,5

The groove for glazing bead

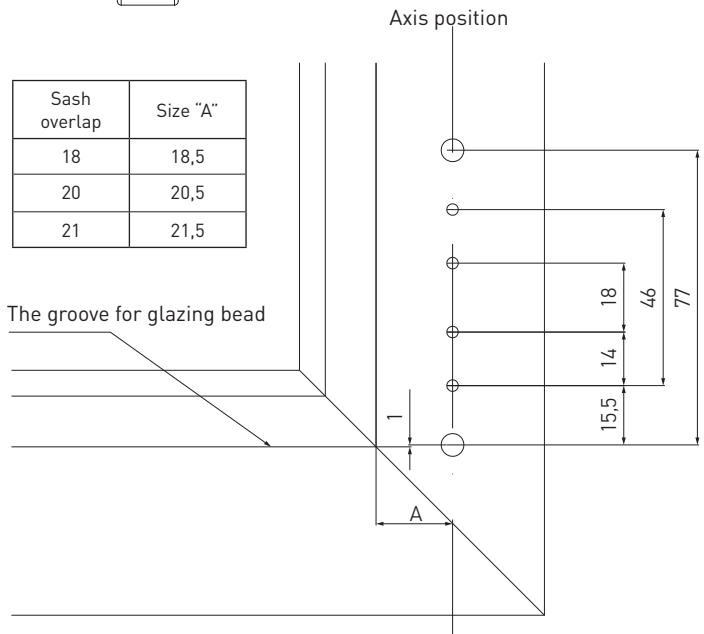

Description	Side opening	A	C	B	kg			Part No.
Corner bearing, 100 kg, with installation on mullion	L/R	12	—	—	100	4 / 3,9x40	250	A5045-00-N03
Description	Side opening	A	C	B	kg			Part No.
Drilling jig for frame hinges	L/R	12	20	—	—	Ø3/6	50	A7002-10-N09
Drilling jig for frame hinges	L/R	12	21	—	—	Ø3/6	50	A7002-30-N09
Description	Side opening	A	C	B	kg			Part No.
Bottom cover of corner bearing	L/R	—	—	—	—	—	500	A7007-10-N**
Top cover of corner bearing	L/R	—	—	—	—	—	500	A7008-10-N**

A - sash rebate gap / C - sash overlap / B - sash groove position  
\*\* - for decorative covers in other colors look at p. 27



# Drill-in corner hinge

## Hinges

Drill-in corner hinge

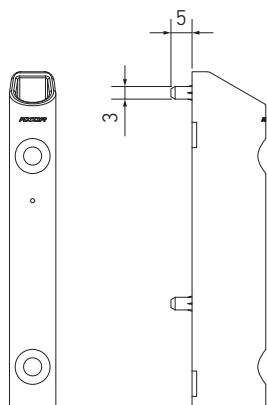

± 2\*

- used for 18-22 mm sash overlap;
- for appropriate sash hinge look at p. 13;
- for decorative covers in other colors look at p. 27.

\* vertical adjustment, mm

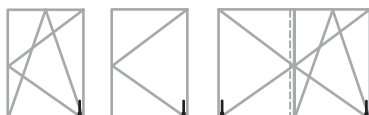

Cover of the drill-in corner hinge



Axis of sash groove position

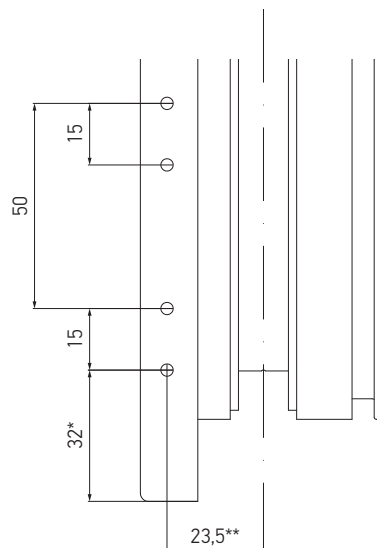

- \* for 20-mm sash overlap
- \*\* for 13-mm sash groove position

Description	Side opening	A	C	B	kg			Part No.
Drill-in corner hinge 3x5	L/R	—	—	—	100	2 / 4x40	250	A5003-00-N03
Description	Side opening	A	C	B	kg			Part No.
Drilling jig for sash hinges	L/R	12	20	13/9	—	∅3	80	A7003-00-N09
Drilling jig for sash hinges	L/R	12	21	13/9	—	∅3	80	A7003-20-N09
Description	Side opening	A	C	B	kg			Part No.
Cover of the drill-in corner hinge	L/R	—	—	—	—	—	500	A7006-10-N**

A - sash rebate gap / C - sash overlap / B - sash groove position  
 \*\* - for decorative covers in other colors look at p. 27



**Drill-in corner hinge**

Hinges

Drill-in corner hinge  
with gasket pressure adjustment

Cover of the drill-in corner hinge

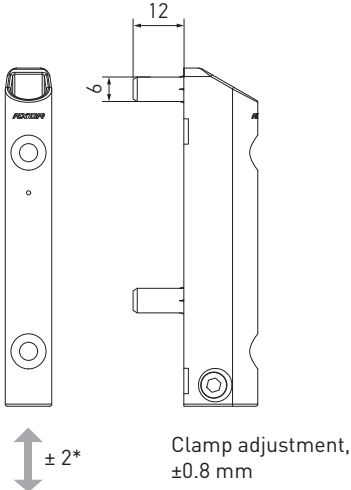

- used for 18-22 mm sash overlap;
- for appropriate sash hinge look at p. 13, 14;
- for decorative covers in other colors look at p. 27.

\* vertical adjustment, mm

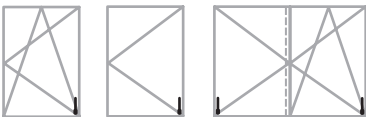

Axis of sash groove position

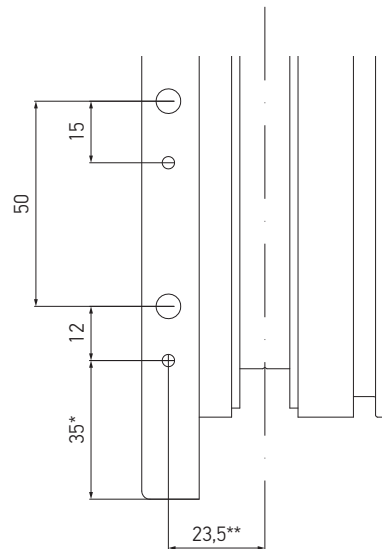

- \* for 20-mm sash overlap
- \*\* for 13-mm sash groove position

Description	Side opening	A	C	B	kg			Part No.
Drill-in corner hinge AD 6x12	L/R	—	—	—	100	2 / 4x40	250	A5007-00-N03
Description	Side opening	A	C	B	kg			Part No.
Drilling jig for sash hinges AD	L/R	12	20	13/9	—	∅3/6	80	A7003-10-N09
Drilling jig for sash hinges AD	L/R	12	21	13/9	—	∅3/6	80	A7003-30-N09
Description	Side opening	A	C	B	kg			Part No.
Cover of the drill-in corner hinge	L/R	—	—	—	—	—	500	A7006-10-N**

A - sash rebate gap / C - sash overlap / B - sash groove position  
\*\* - for decorative covers in other colors look at p. 27



# Drill-in corner hinge

## Hinges

Drill-in corner hinge 6x16/26 with gasket pressure adjustment

Cover of the drill-in corner hinge

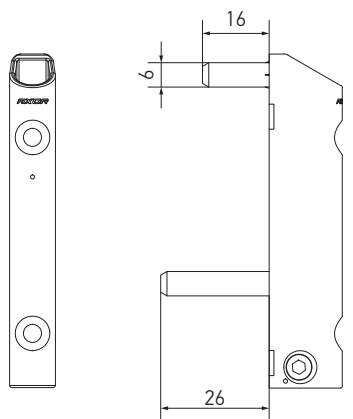

Clamp adjustment, ±0.8 mm

- used for 18-22 mm sash overlap;
- for appropriate sash hinge look at p. 14;
- for decorative covers in other colors look at p. 27.

\* vertical adjustment, mm

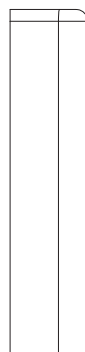
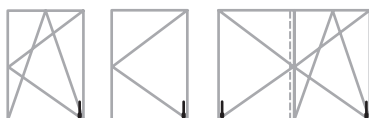

Axis of sash groove position

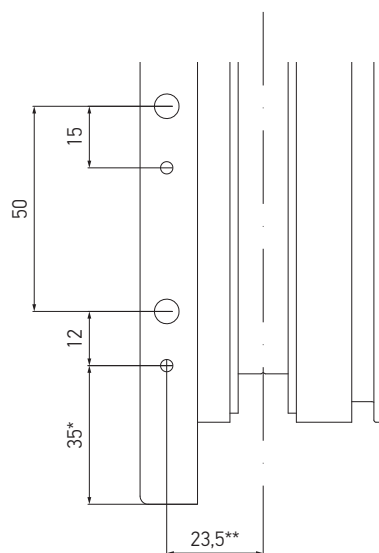

- \* for 20-mm sash overlap
- \*\* for 13-mm sash groove position

Description	Side opening	A	C	B	kg			Part No.
Drill-in corner hinge AD 6x16/26	L/R	—	—	—	130	2 / 4x40	250	A5006-00-N03
Description	Side opening	A	C	B	kg			Part No.
Drilling jig for sash hinges AD	L/R	12	20	13/9	—	Ø3/6	80	A7003-10-N09
Drilling jig for sash hinges AD	L/R	12	21	13/9	—	Ø3/6	80	A7003-30-N09
Description	Side opening	A	C	B	kg			Part No.
Cover of the drill-in corner hinge	L/R	—	—	—	—	—	500	A7006-10-N**

A - sash rebate gap / C - sash overlap / B - sash groove position  
 \*\* - for decorative covers in other colors look at p. 27



**Drill-in corner hinge**

Hinges

Drill-in corner hinge 6x16/26

Cover of the drill-in corner hinge

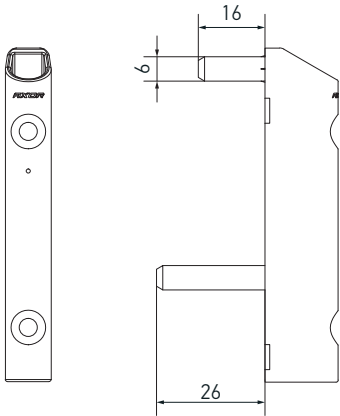

- used for 18-22 mm sash overlap;
- for appropriate sash hinge look at p. 13, 14;
- for decorative covers in other colors look at p. 27.

\* vertical adjustment, mm

Axis of sash groove position

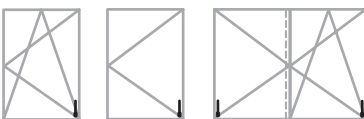
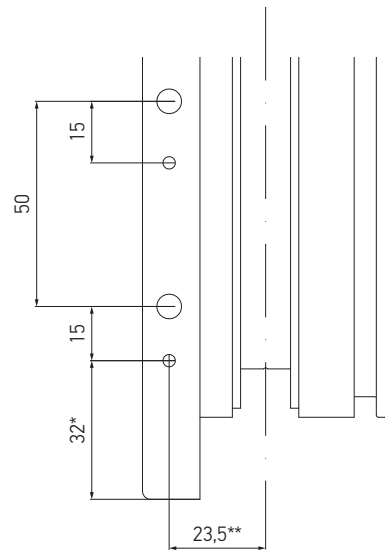

- \* for 20-mm sash overlap
- \*\* for 13-mm sash groove position

Description	Side opening	A	C	B	kg			Part No.
Drill-in corner hinge 6x16/26	L/R	—	—	—	100	2 / 4x40	250	A5008-00-N03
Description	Side opening	A	C	B	kg			Part No.
Drilling jig for sash hinges	L/R	12	20	13/9	—	∅3/6	80	A7003-40-N09
Description	Side opening	A	C	B	kg			Part No.
Cover of the drill-in corner hinge	L/R	—	—	—	—	—	500	A7006-10-N**

A - sash rebate gap / C - sash overlap / B - sash groove position  
 \*\* - for decorative covers in other colors look at p. 27



**Rebate corner hinge**

Hinges

Rebate corner hinge

Cover of rebate corner hinge

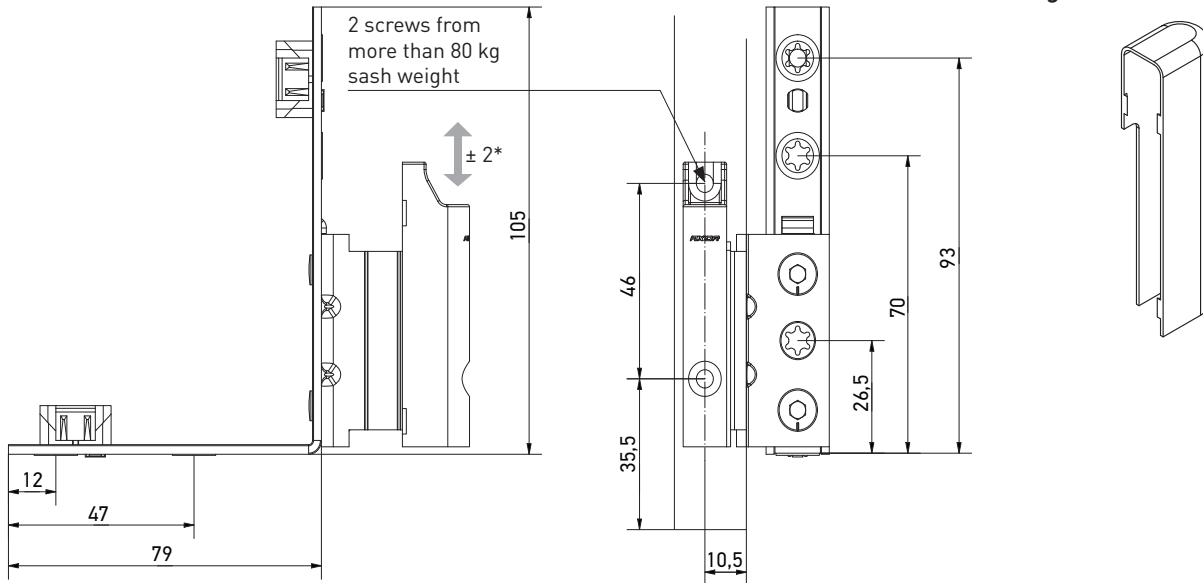

- used for 18, 20 mm sash overlap;
  - for appropriate sash hinge look at p. 13, 14;
  - for decorative covers in other colors look at p. 27.
- \* vertical adjustment, mm

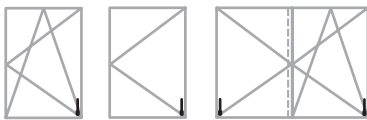

Description	Side opening	A	C	B	kg			Part No.
Rebate corner hinge 20/9 left/right	L/R	12	20	9	130	7	50	A5009-09-L/R03
Rebate corner hinge 18/9 left/right	L/R	12	18	9	130	7	50	A5010-09-L/R03
Rebate corner hinge 20/13 left/right	L/R	12	20	13	130	7	50	A5009-13-L/R03
Rebate corner hinge 18/13 left/right	L/R	12	18	13	130	7	50	A5010-13-L/R03
Cover of rebate corner hinge, left	L	—	—	—	—	—	500	A7009-00-L**
Cover of rebate corner hinge, right	R	—	—	—	—	—	500	A7009-00-R**

A - sash rebate gap / C - sash overlap / B - sash groove position  
 \*\* - for decorative covers in other colors look at p. 27



**Stay arm bearing**

Hinges

Stay arm bearing

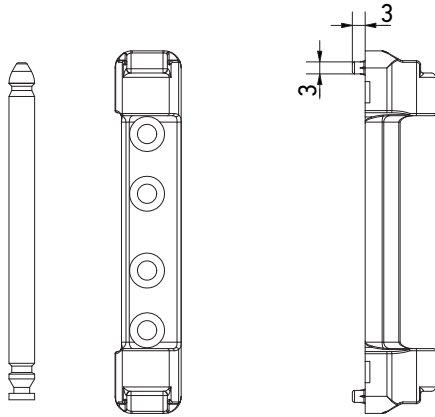

Cover of stay arm bearing

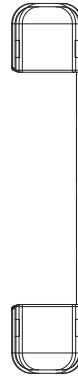

- for appropriate sash hinge look at p. 23;
- for decorative covers in other colors look at p. 27;
- the pin is supplied with hinge.

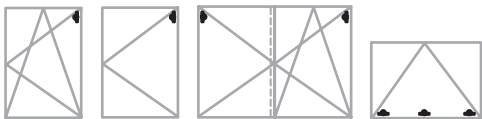
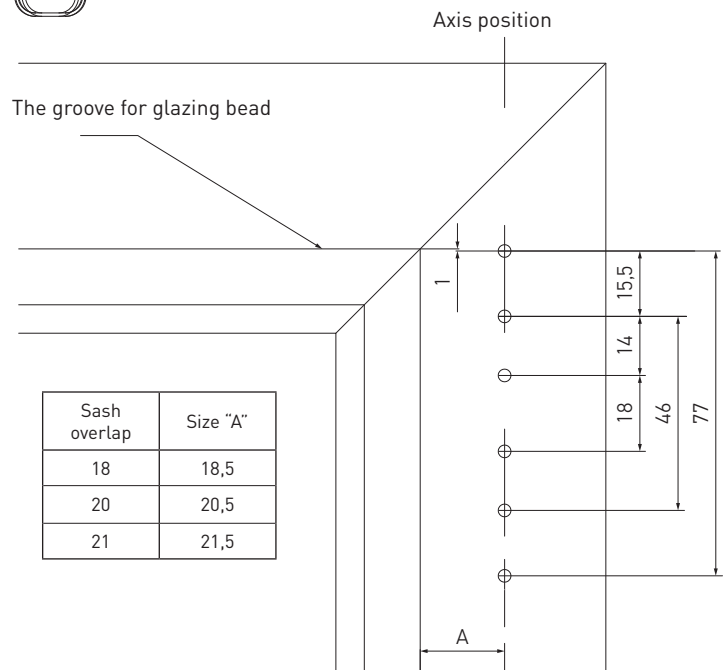

Description	Side opening	A	C	B	kg			Part No.
Stay arm bearing 3x3	L/R	12	—	—	100	4 / 3,9x40	250	A5001-00-N03
Description	Side opening	A	C	B	kg			Part No.
Drilling jig for frame hinges	L/R	12	20	—	—	∅3	50	A7002-00-N09
Drilling jig for frame hinges	L/R	12	21	—	—	∅3	50	A7002-20-N09
Description	Side opening	A	C	B	kg			Part No.
Cover of stay arm bearing	L/R	—	—	—	—	—	500	A7005-10-N**

A - sash rebate gap / C - sash overlap / B - sash groove position  
 \*\* - for decorative covers in other colors look at p. 27



**Stay arm bearing**

Hinges

Stay arm bearing 6x12

Cover of stay arm bearing

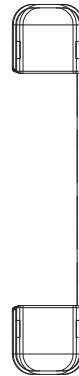
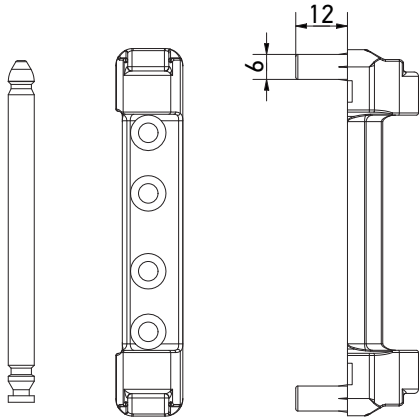

- for appropriate sash hinge look at p. 23;
- for decorative covers in other colors look at p. 27;
- the pin is supplied with hinge.

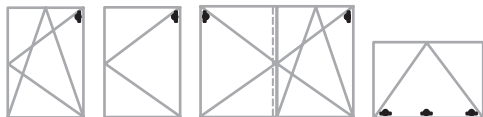
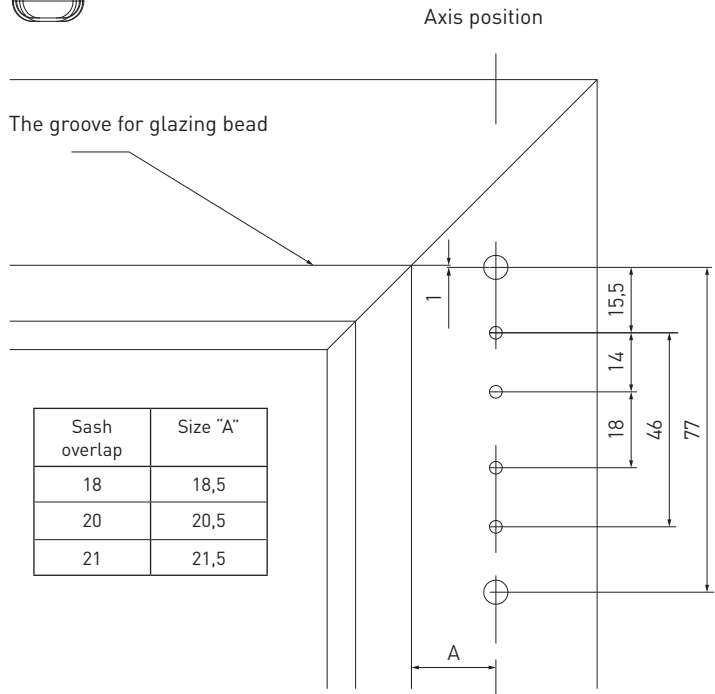

Description	Side opening	A	C	B	kg			Part No.
Stay arm bearing 6x12 mm	L/R	12	—	—	100	4 / 3,9x40	250	A5016-00-N03
Description	Side opening	A	C	B	kg			Part No.
Drilling jig for frame hinges	L/R	12	20	—	—	∅3/6	50	A7002-10-N09
Drilling jig for frame hinges	L/R	12	21	—	—	∅3/6	50	A7002-30-N09
Description	Side opening	A	C	B	kg			Part No.
Cover of stay arm bearing	L/R	—	—	—	—	—	500	A7005-10-N**

A - sash rebate gap / C - sash overlap / B - sash groove position  
 \*\* - for decorative covers in other colors look at p. 27





**Stay arm bearing**

Hinges

Stay arm bearing 6x24

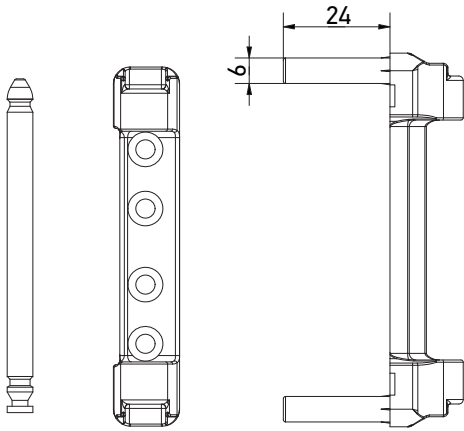

Cover of stay arm bearing



- for appropriate sash hinge look at p. 23;
- for decorative covers in other colors look at p. 27;
- the pin is supplied with hinge.

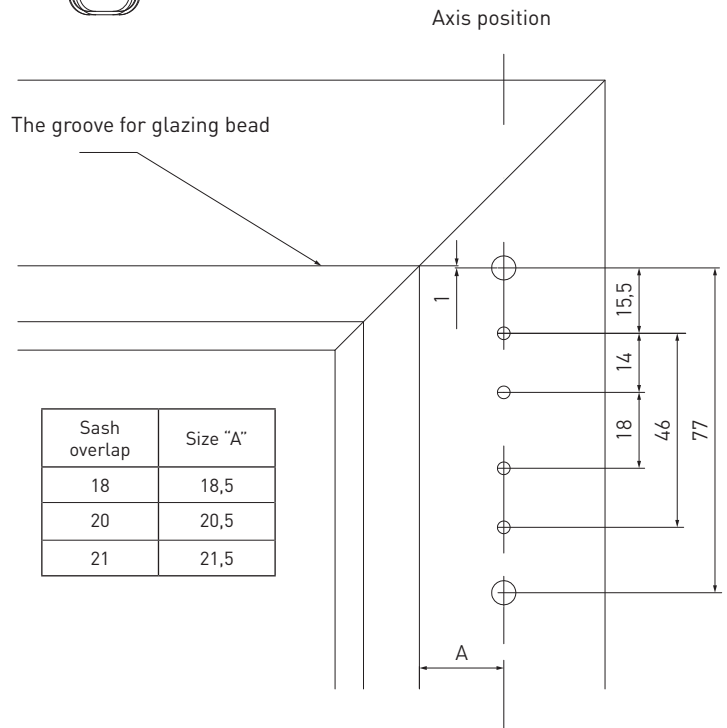
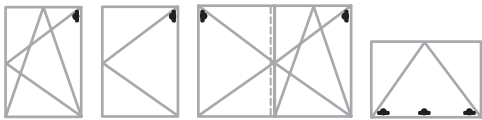

Description	Side opening	A	C	B	kg			Part No.
Stay arm bearing 6x24	L/R	12	—	—	130	4 / 3,9x40	250	A5005-00-N03
Description	Side opening	A	C	B	kg			Part No.
Drilling jig for frame hinges	L/R	12	20	—	—	Ø3/6	50	A7002-10-N09
Drilling jig for frame hinges	L/R	12	21	—	—	Ø3/6	50	A7002-30-N09
Description	Side opening	A	C	B	kg			Part No.
Cover of stay arm bearing	L/R	—	—	—	—	—	500	A7005-10-N**

A - sash rebate gap / C - sash overlap / B - sash groove position  
 \*\* - for decorative covers in other colors look at p. 27



**Top sash hinge**

Hinges

Top sash hinge

Cover of top sash hinge

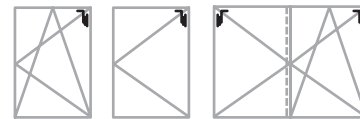
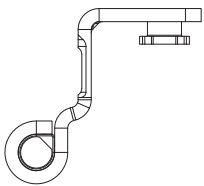
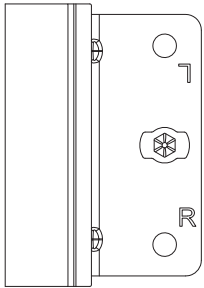

- for appropriate sash hinge look at p. 20-22;
- for decorative covers in other colors look at p. 27;
- installation with 4-mm hexagonal key.

Description	Side opening	A	C	B	kg			Part No.
Top sash hinge 12/20-9	L/R	12	20	9	130	—	150	K5001-09-N03
Top sash hinge 12/20-10	L/R	12	20	9	130	—	150	K5001-10-N03
Top sash hinge 12/20-13	L/R	12	20	13	130	—	150	K5001-13-N03
Top sash hinge 12/20-14	L/R	12	20	13	130	—	150	K5001-14-N03
Top sash hinge 12/21-13	L/R	12	21	13	130	—	150	K5004-13-N03
Top sash hinge 12/18-09	L/R	12	18	9	130	—	150	K5006-09-N03
Top sash hinge 12/18-13	L/R	12	18	13	130	—	150	K5006-13-N03
Description	Side opening	A	C	B	kg			Part No.
Cover of top sash hinge	L/R	—	—	—	—	—	500	A7004-10-N**

A - sash rebate gap / C - sash overlap / B - sash groove position  
 \*\* - for decorative covers in other colors look at p. 27



**Bottom hinges for tilt sash**

Hinges

Bottom hinges for tilt sash

Cover of top sash hinge

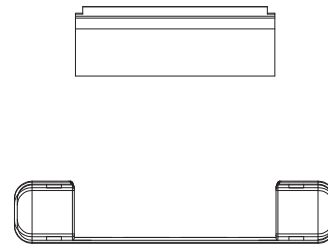
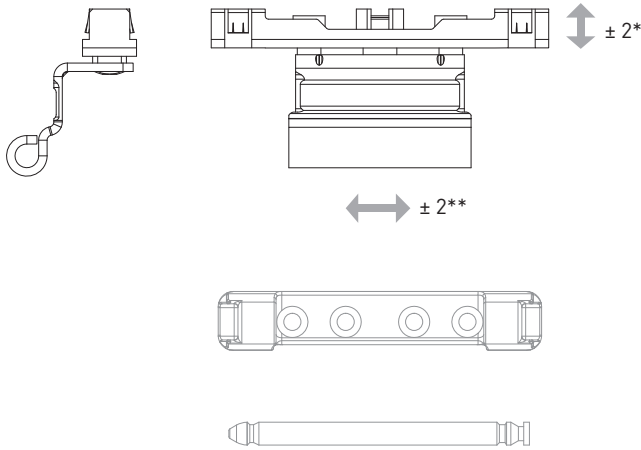

- \* vertical adjustment, mm;
- \*\* horizontal adjustment, mm;
- \*\*\* ONLY FOR TILT SASH

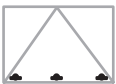

Description	Side opening	A	C	B	kg			Part No.
Bottom hinges for tilt sash 12/20-9	L/R	12	20	9	50*	2 / 4×25	100	A7014-09-N03
Bottom hinges for tilt sash 12/20-12	L/R	12	20	12	50*	2 / 4×25	100	A7014-12-N03
Bottom hinges for tilt sash 12/20-13	L/R	12	20	13	50*	2 / 4×25	100	A7014-13-N03
Bottom hinges for tilt sash 12/20-14	L/R	12	20	14	50*	2 / 4×25	100	A7014-14-N03
Description	Side opening	A	C	B	kg			Part No.
Cover of top sash hinge	L/R	—	—	—	—	—	500	A7004-10-N**

A - sash rebate gap / C - sash overlap / B - sash groove position  
 \* - for 2-hinges set  
 \*\* - for decorative covers in other colors look at p. 27



**Middle hinge**

Hinges

Middle hinge

Cover of top sash hinge

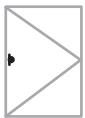
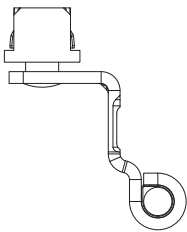
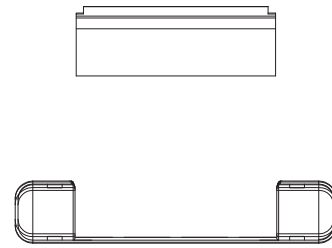
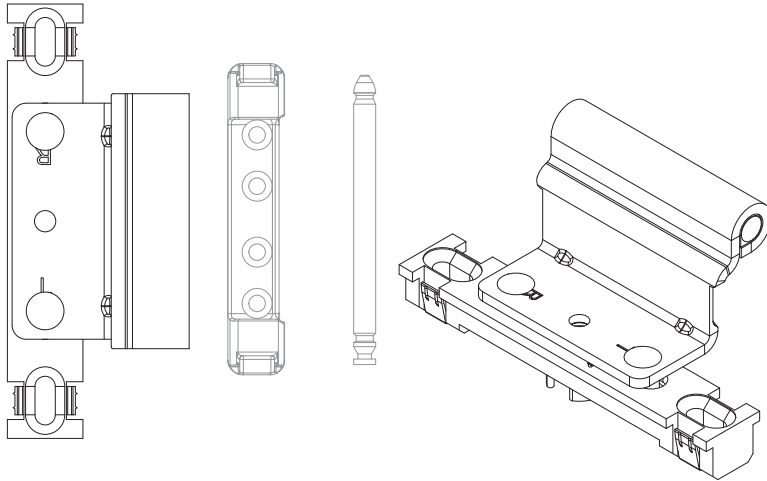

Description	SRH (mm)		A	C	B	kg			Part No.
Middle hinge 12/20-9	751-1710	1	12	20	9	50*	2 / 4x25	100	A7030-09-N03
	1711-2360	2							
Middle hinge 12/20-12	751-1710	1	12	20	12	50*	2 / 4x25	100	A7030-12-N03
	1711-2360	2							
Middle hinge 12/20-13	751-1710	1	12	20	13	50*	2 / 4x25	100	A7030-13-N03
	1711-2360	2							
Middle hinge 12/20-14	751-1710	1	12	20	14	50*	2 / 4x25	100	A7030-14-N03
	1711-2360	2							
Description	SRH (mm)		A	C	B	kg			Part No.
Cover of top sash hinge	751-1710	1	—	—	—	—	—	500	A7004-10-N**
	1711-2360	2	—	—	—	—	—		

A - sash rebate gap / C - sash overlap / B - sash groove position  
\* - for 2-hinges set

\*\* - for decorative covers in other colors look at p. 27

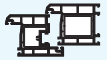
**Covers**
**Hinges**

Description	Sketch	Color		Part No.
Cover of top sash hinge		White RAL 9016	500	A7004-10-N01
		Brown RAL 8022	500	A7004-10-N02
		Silver F1	500	A7004-10-N03
		Cream RAL 9001	500	A7004-10-N04
		Gold F3	500	A7004-10-N05
		Bronze F4	500	A7004-10-N06
		Black RAL 9005	500	A7004-10-N07
Cover of stay arm bearing		White RAL 9016	500	A7005-10-N01
		Brown RAL 8022	500	A7005-10-N02
		Silver F1	500	A7005-10-N03
		Cream RAL 9001	500	A7005-10-N04
		Gold F3	500	A7005-10-N05
		Bronze F4	500	A7005-10-N06
		Black RAL 9005	500	A7005-10-N07
Cover of the drill-in corner hinge		White RAL 9016	500	A7006-10-N01
		Brown RAL 8022	500	A7006-10-N02
		Silver F1	500	A7006-10-N03
		Cream RAL 9001	500	A7006-10-N04
		Gold F3	500	A7006-10-N05
		Bronze F4	500	A7006-10-N06
		Black RAL 9005	500	A7006-10-N07
Bottom cover of corner bearing		White RAL 9016	500	A7007-10-N01
		Brown RAL 8022	500	A7007-10-N02
		Silver F1	500	A7007-10-N03
		Cream RAL 9001	500	A7007-10-N04
		Gold F3	500	A7007-10-N05
		Bronze F4	500	A7007-10-N06
		Black RAL 9005	500	A7007-10-N07
Top cover of corner bearing		White RAL 9016	500	A7008-10-N01
		Brown RAL 8022	500	A7008-10-N02
		Silver F1	500	A7008-10-N03
		Cream RAL 9001	500	A7008-10-N04
		Gold F3	500	A7008-10-N05
		Bronze F4	500	A7008-10-N06
		Black RAL 9005	500	A7008-10-N07
Cover of rebate corner hinge		White RAL 9016	500	A7009-10-L01/R01
		Brown RAL 8022	500	A7009-10-L02/R02
		Silver F1	500	A7009-10-L03/R03
		Cream RAL 9001	500	A7009-10-L04/R04
		Gold F3	500	A7009-10-L05/R05
		Bronze F4	500	A7009-10-L06/R06
		Black RAL 9005	500	A7009-10-L07/R07

**AXOR**<sup>®</sup>

**KOMFORT LINE** **K-3**  
Smart&Quick

Gears

AXOR



**Drilling and milling a sash  
for 7.5-mm backset gear**

Gears

Drilling and milling a sash for 7.5-mm backset gear

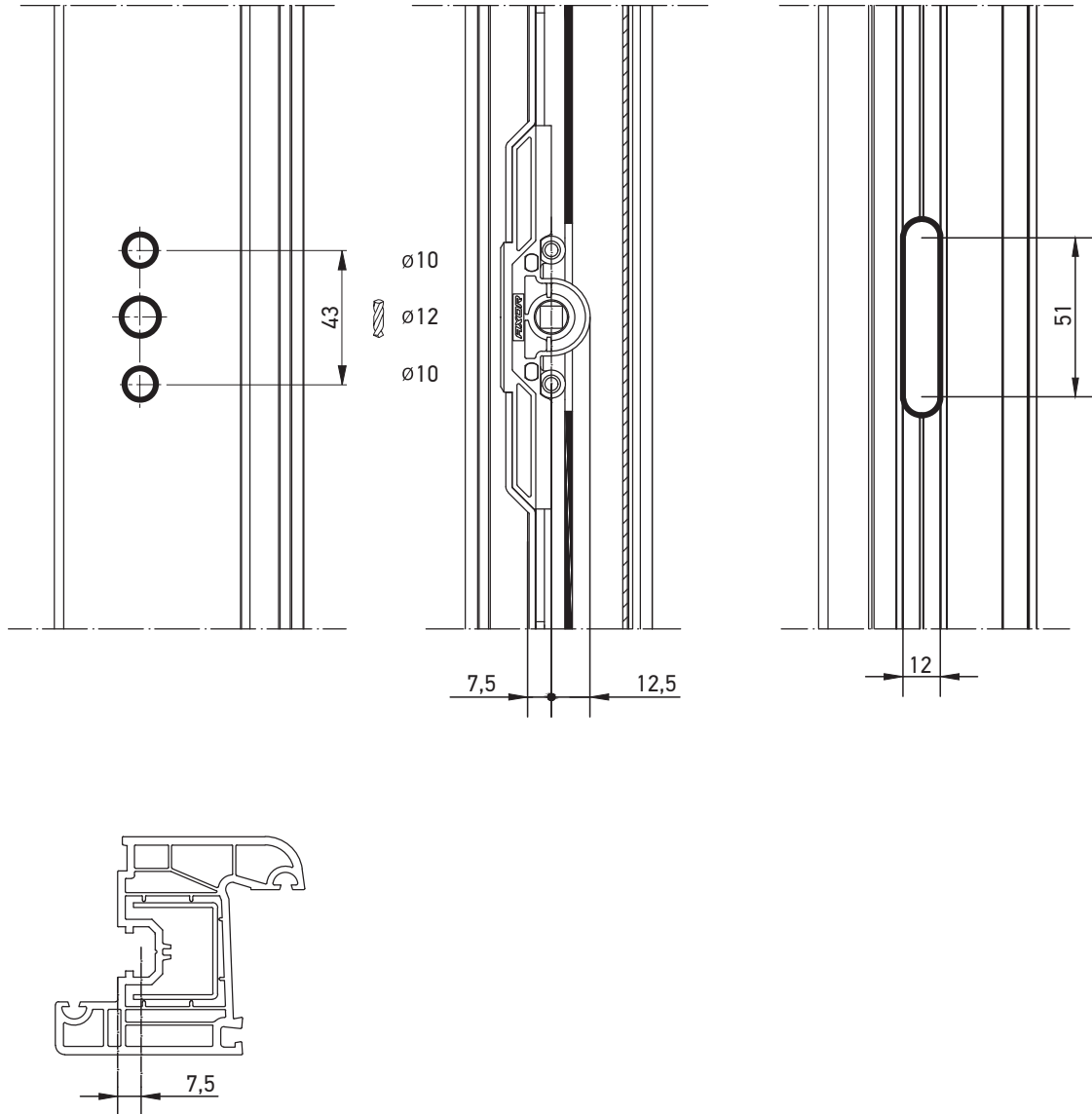



# Drilling and milling a sash for 15-mm backset gear

Gears

Drilling and milling a sash for 15-mm backset gear

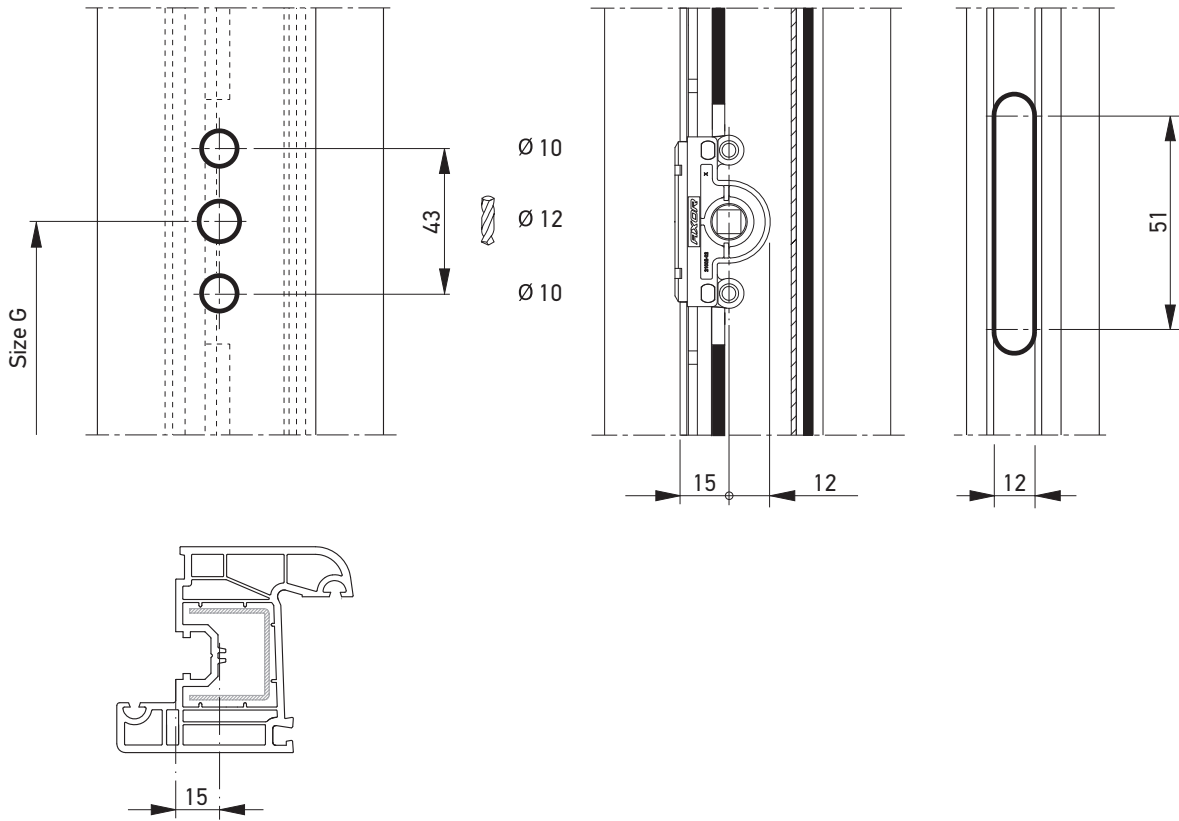





## Drilling and milling a sash for 25, 30, 35-mm backset gear

Gears

Drilling and milling a sash for 25, 30, 35-mm backset gear,  
handle position is central

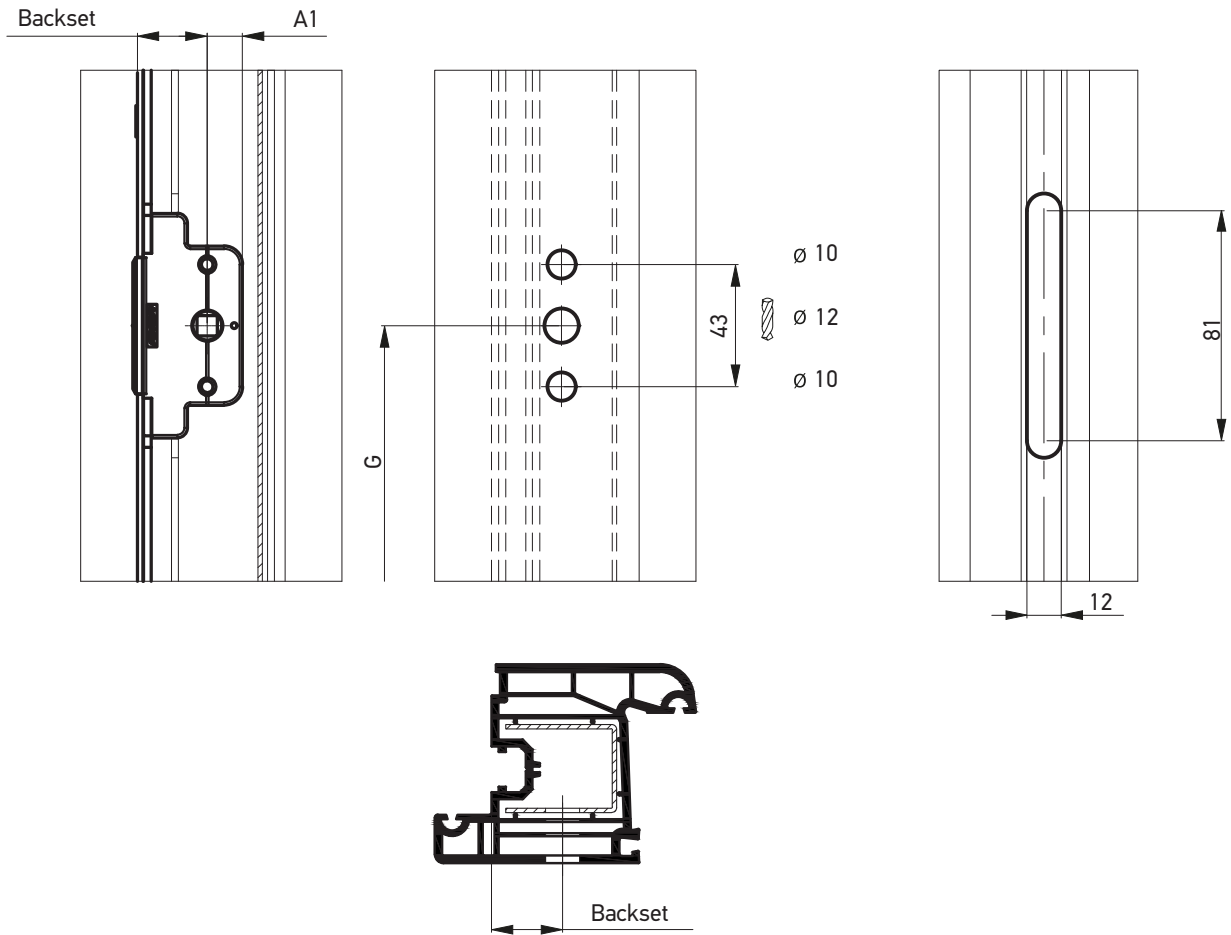

Backset	A1, mm
25	12,4
30	12,4
35	12,4



# Drilling and milling a sash for 25, 30, 35-mm backset gear

Gears

Drilling and milling a sash for 25, 30, 35-mm backset gear,  
lockable, handle position is central

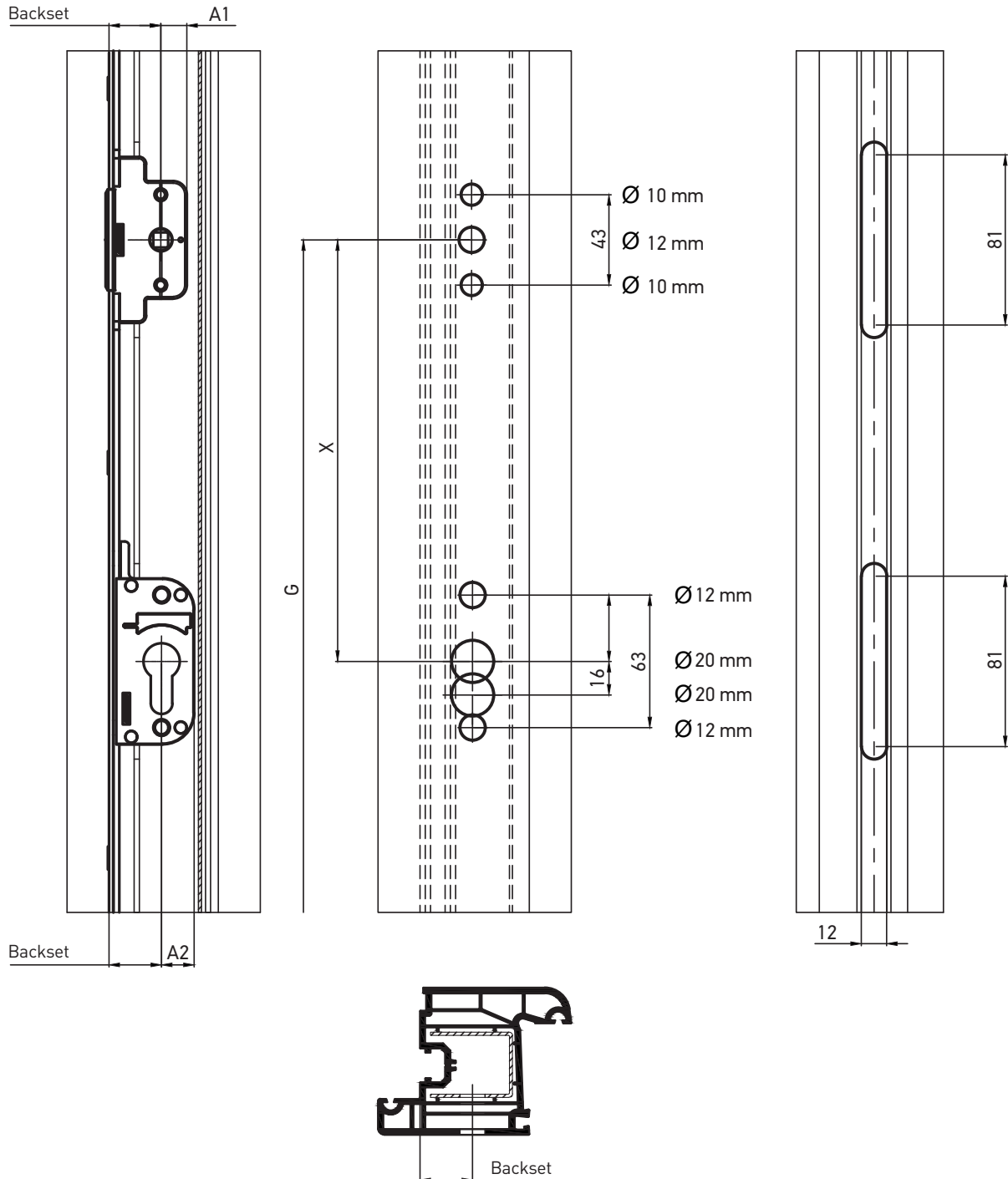

Backset	A1, mm	A2, mm
25	12,4	15,5
30	12,4	15,5
35	12,4	15,5

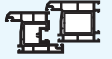

**Drilling and milling a sash for sliding system gear for sliding system gear**

Gears

Drilling and milling a sash for sliding system gear lockable, backset 15 mm.

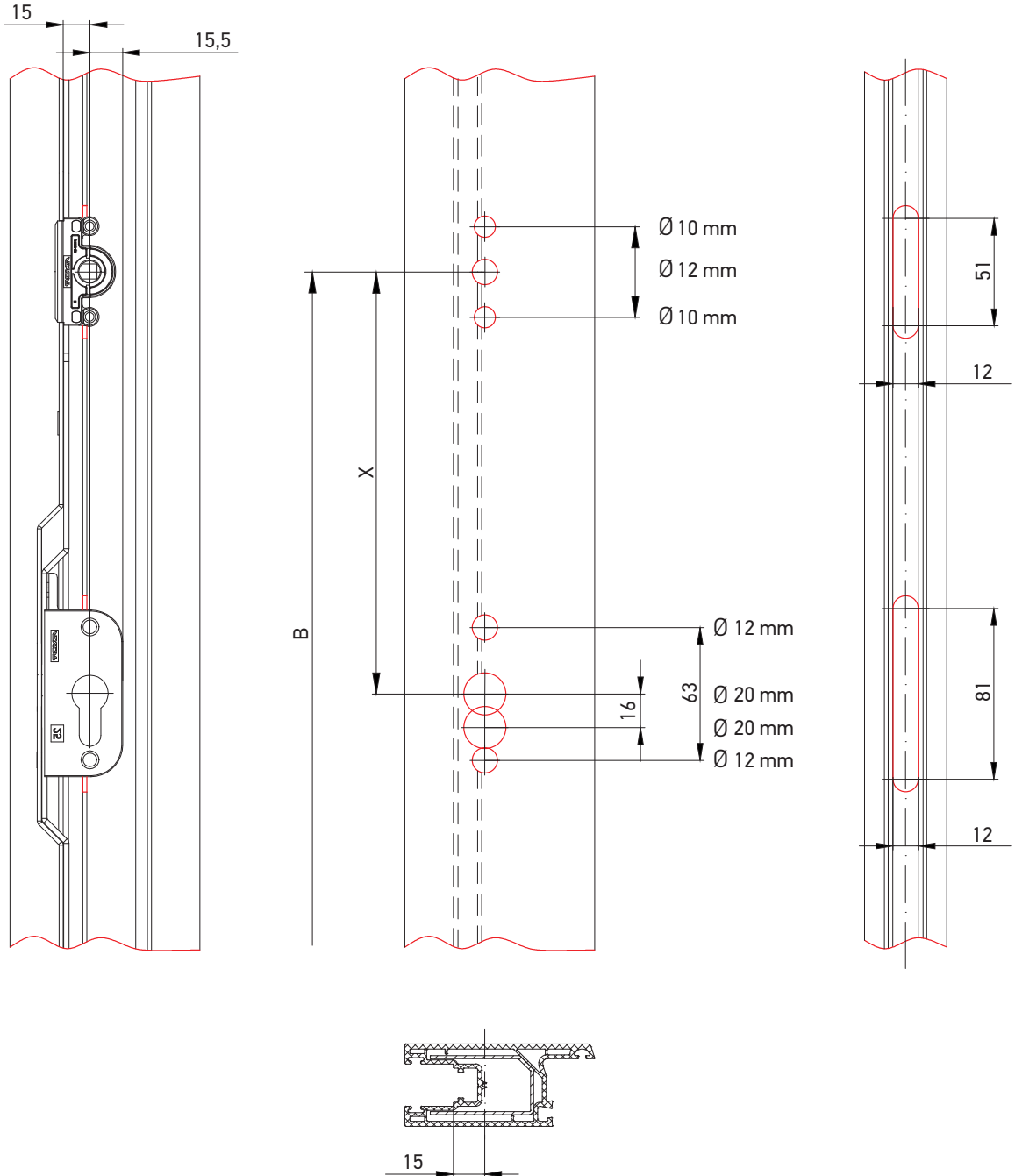



**Tilt and turn variable gear**

Gears

Tilt and turn variable gear, backset 15 mm.

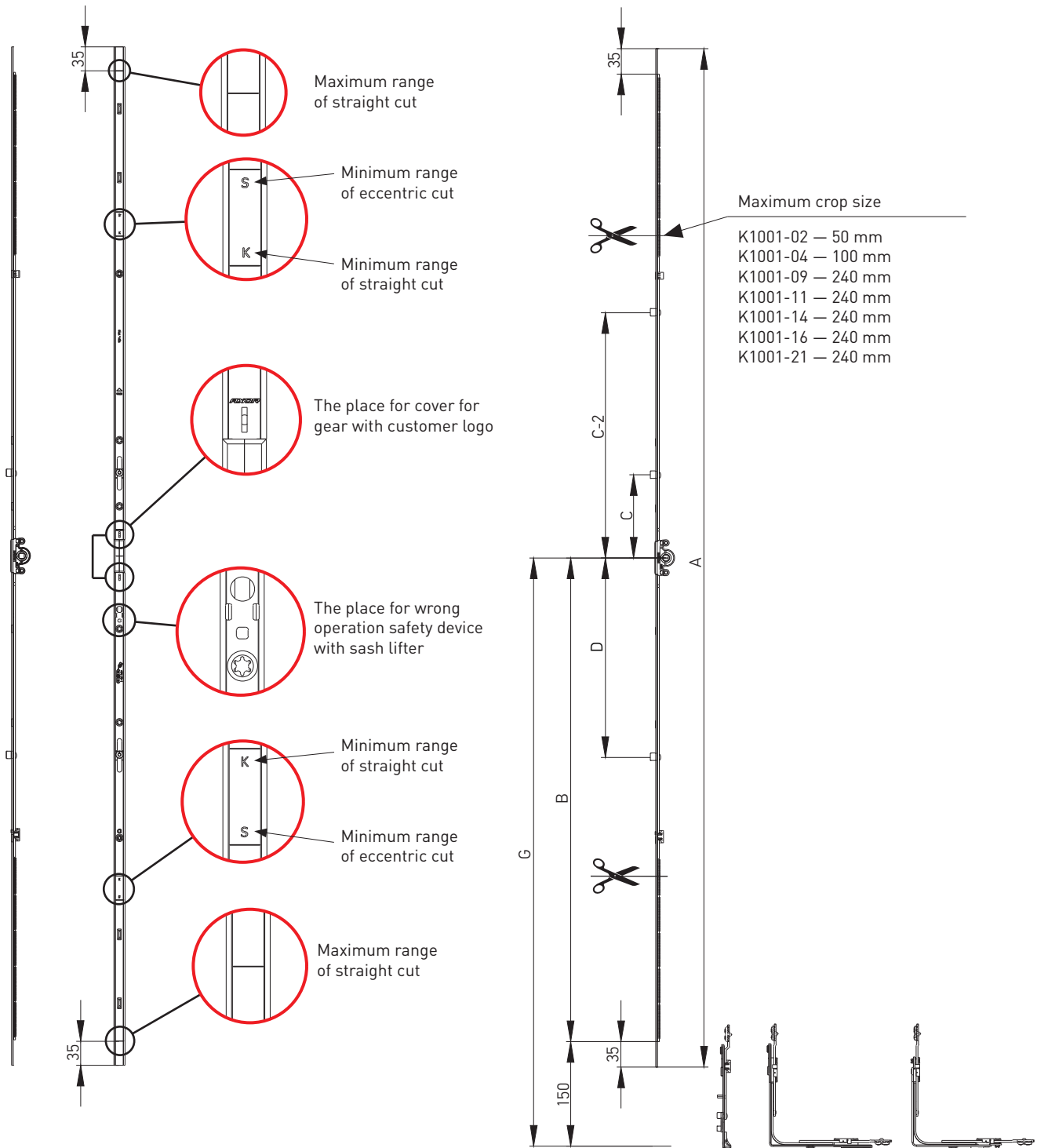

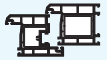

## Tilt and turn variable gear

### Gears

Description	SRH (mm)	Dimensions										Part No.
		G	A	B	C	C-2	D					
Tilt and turn variable gear 0, L=320, 450-550*	450-550	225-275	320	125	—	—	—	—	—	—	20	K1001-02-N03
Tilt and turn variable gear 1, L=520, 551-750*	551-750	275-375	520	225	—	—	—	—	—	2	20	K1001-04-N03
Tilt and turn variable gear 2, L=1000, 751-1230, 1 ML	751-1230	375-615	1000	465	120	—	—	1	—	4	20	K1001-09-N03
Tilt and turn variable gear 3, L=1200, 950-1430, 1 ML	950-1430	475-715	1200	565	120	—	—	1	—	5	20	K1001-11-N03
Tilt and turn variable gear 4, L=1480, 1231-1710, 2 ML	1231-1710	615-855	1480	705	120	—	290	2	—	6	20	K1001-14-N03
Tilt and turn variable gear 5, L=1680, 1431-1910, 2 ML	1431-1910	715-955	1680	805	265	—	390	2	—	7	10	K1001-16-N03
Tilt and turn variable gear 6, L=2160, 1911-2390, 3 ML	1911-2390	955-1195	2160	1045	120	595	490	3	—	11	10	K1001-21-N03
Tilt and turn variable gear 2, L=1000, 751-1230, 1 MR	751-1230	375-615	1000	465	120	—	—	—	1	4	20	K1031-09-N03
Tilt and turn variable gear 3, L=1200, 950-1430, 1 MR	950-1430	475-715	1200	565	120	—	—	—	1	5	20	K1031-11-N03
Tilt and turn variable gear 4, L=1480, 1231-1710, 2 MR	1231-1710	615-855	1480	705	120	—	290	—	2	6	20	K1031-14-N03
Tilt and turn variable gear 5, L=1680, 1431-1910, 2 MR	1431-1910	715-955	1680	805	265	—	390	—	2	7	10	K1031-16-N03
Tilt and turn variable gear 6, L=2160, 1911-2390, 3 MR	1911-2390	955-1195	2160	1045	120	595	490	—	3	11	10	K1031-21-N03

\* there is not a place for the micro lift

- handle position is central;

- backset 15 mm.



**Constant tilt & turn gear**

Gears

Constant tilt & turn gear

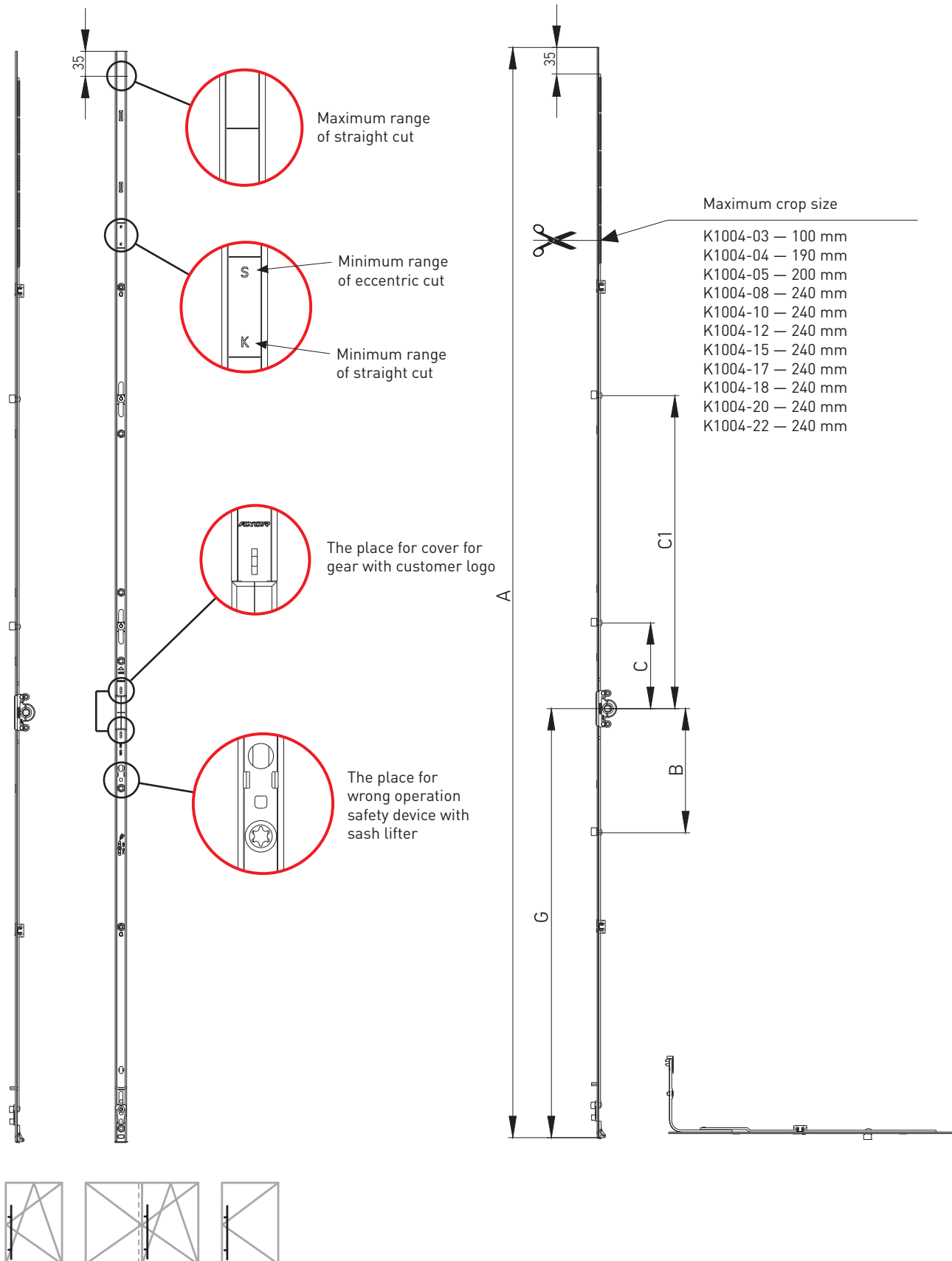



## Constant tilt &amp; turn gear

## Gears

Description	SRH (mm)	Dimensions									Part No.
		G	A	B	C	C-1					
Constant gear 0**, L=435, 360-550	360-550	140	435	0	0	0	—	—	1	20	K1004-04-N03
Constant gear 1, L=385, G=175, 400-500*	400-500	175	385	—	—	—	—	—	2	20	K1004-03-N03
Constant gear 2, L=565, G=200, 480-680*	480-680	200	565	—	—	—	—	—	3	20	K1004-05-N03
Constant gear 3, L=805, G=300, 681-920, 1 ML	681-920	300	805	—	120	—	1	—	5	20	K1004-08-N03
Constant gear 4, L=1045, G=450, 921-1160, 1 ML	921-1160	450	1045	—	120	—	1	—	5	20	K1004-10-N03
Constant gear 5, L=1285, G=600, 1161-1400, 1 ML	1161-1400	600	1285	—	120	—	1	—	7	20	K1004-12-N03
Constant gear 6, L=1525, G=600, 1401-1640, 2 ML	1401-1640	600	1525	—	120	438	2	—	8	20	K1004-15-N03
Constant gear 7, L=1765, G=600, 1641-1880, 2 ML	1641-1880	600	1765	—	120	643	2	—	9	10	K1004-17-N03
Constant gear 8, L=1765, G=1000, 1641-1880, 2 ML	1641-1880	1000	1765	280	263	—	2	—	10	10	K1004-18-N03
Constant gear 9, L=2005, G=1000, 1881-2120, 2 ML	1881-2120	1000	2005	280	387	—	2	—	11	10	K1004-20-N03
Constant gear 10, L=2245, G=1000, 2121-2360, 3 ML	2120-2360	1000	2245	280	120	723	3	—	13	10	K1004-22-N03
Constant gear 3, L=805, G=300, 681-920, 1 MR	681-920	300	805	—	120	—	—	1	5	20	K1034-08-N03
Constant gear 4, L=1045, G=450, 921-1160, 1 MR	921-1160	450	1045	—	120	—	—	1	5	20	K1034-10-N03
Constant gear 5, L=1285, G=600, 1161-1400, 1 MR	1161-1400	600	1285	—	120	—	—	1	7	20	K1034-12-N03
Constant gear 6, L=1525, G=600, 1401-1640, 2 MR	1401-1640	600	1525	—	120	438	—	2	8	20	K1034-15-N03
Constant gear 7, L=1765, G=600, 1641-1880, 2 MR	1641-1880	600	1765	—	120	643	—	2	9	10	K1034-17-N03
Constant gear 8, L=1765, G=1000, 1641-1880, 2 MR	1641-1880	1000	1765	280	263	—	—	2	10	10	K1034-18-N03
Constant gear 9, L=2005, G=1000, 1881-2120, 2 MR	1881-2120	1000	2005	280	387	—	—	2	11	10	K1034-20-N03
Constant gear 10, L=2245, G=1000, 2121-2360, 3 MR	2120-2360	1000	2245	280	120	723	—	3	13	10	K1034-22-N03

\* there is not a place for the micro lift;

\*\*gear 0 can't be connected with middle lock;

- backset 15 mm.



Constant tilt & turn gear

Gears

Constant tilt & turn gear

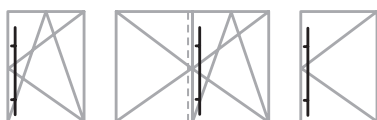
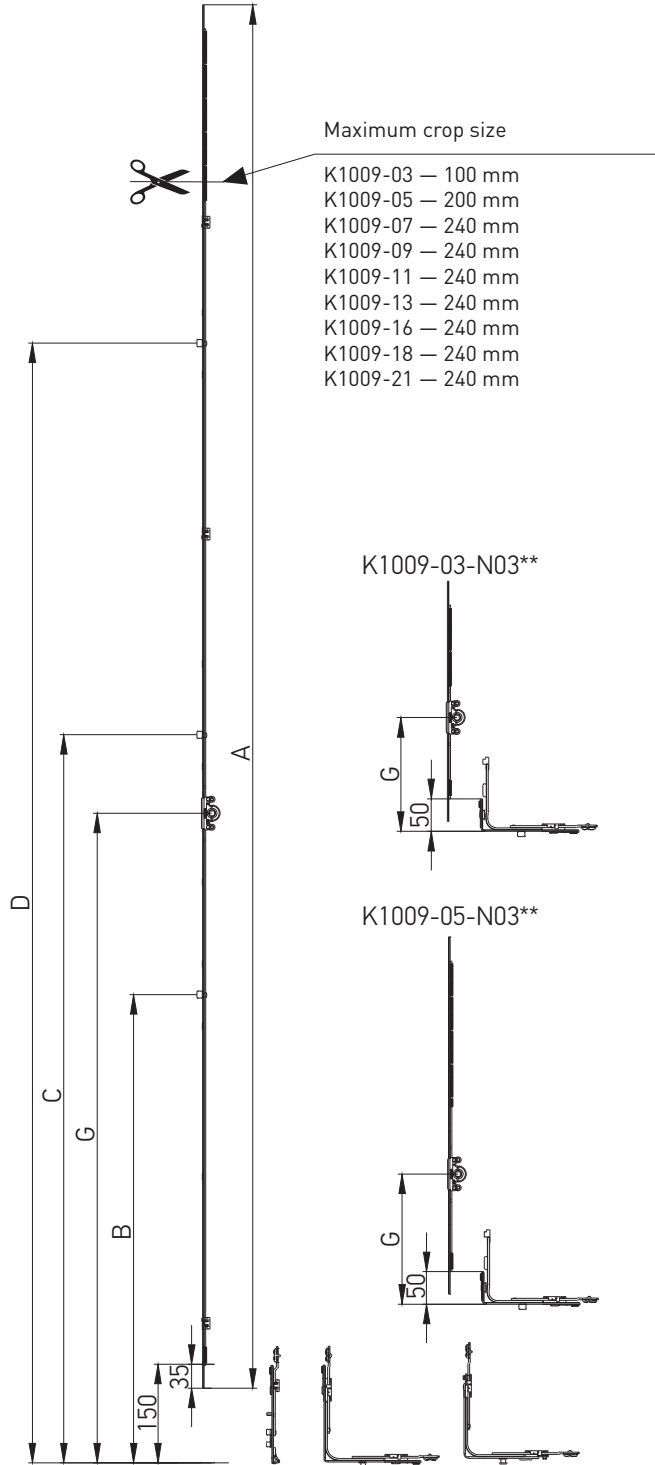
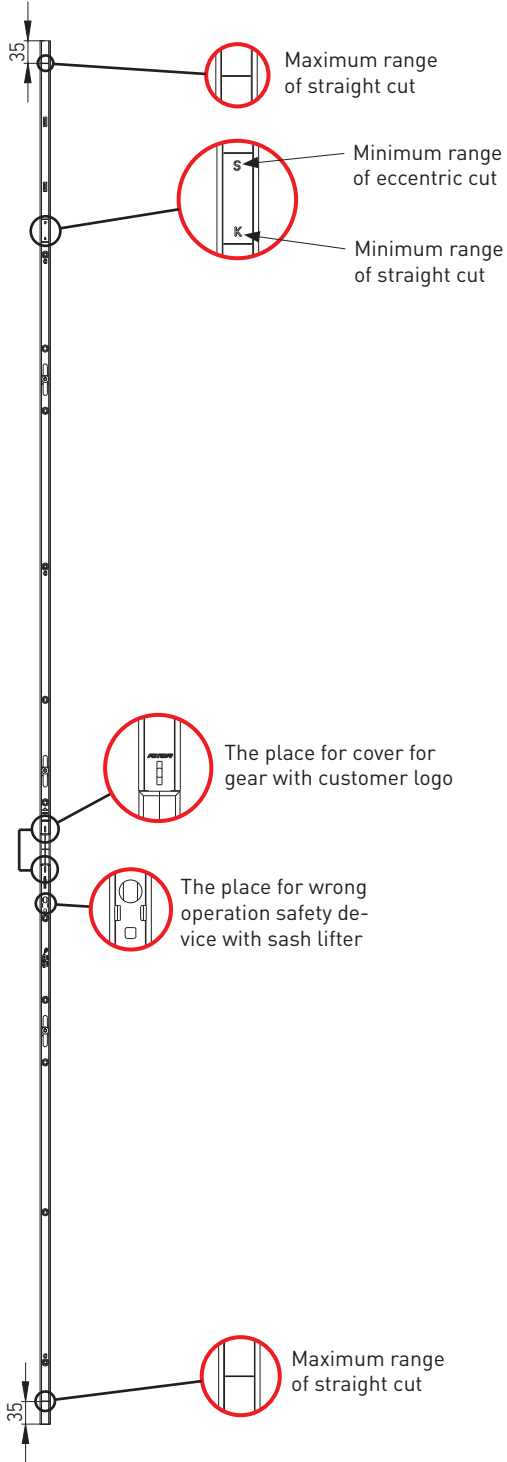





## Constant tilt &amp; turn gear

## Gears

Description	SRH (mm)	Dimensions								Part No.
		G	A	B	C	D				
Constant gear 0**, L=370, 400-500	400-500	175	370	—	—	—	—	—	20	K1009-03-N03
Constant gear 1**, L=550, 480-680*	480-680	200	550	—	—	—	—	2	20	K1009-05-N03
Constant gear 2, L=690, 681-920*	681-920	300	690	—	431	—	1	3	20	K1009-07-N03
Constant gear 3, L=930, 921-1160	921-1160	450	930	—	571	—	1	4	20	K1009-09-N03
Constant gear 4, L=1170, 1161-1400	1161-1400	600	1170	—	721	—	1	6	20	K1009-11-N03
Constant gear 5, L=1410, 1401-1640	1401-1640	600	1410	—	721	1039	2	7	20	K1009-13-N03
Constant gear 6, L=1650, 1641-1880	1641-1880	600	1650	—	721	1244	2	8	10	K1009-16-N03
Constant gear 7, L=1650, 1641-1880	1641-1880	1000	1650	721	1264	—	2	8	10	K1009-17-N03
Constant gear 8, L=1890, 1881-2120	1881-2120	1000	1890	721	1388	—	2	9	10	K1009-18-N03
Constant gear 9, L=2130, 2121-2360	2121-2360	1000	2130	721	1121	1724	3	11	10	K1009-21-N03

\* there is not a place for the micro lift;

\*\* connecting with narrow corner transmission

- Backset 15 mm.



**Constant tilt & turn gear**

Gears

**Constant tilt & turn gear**

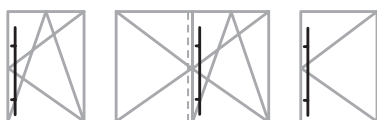
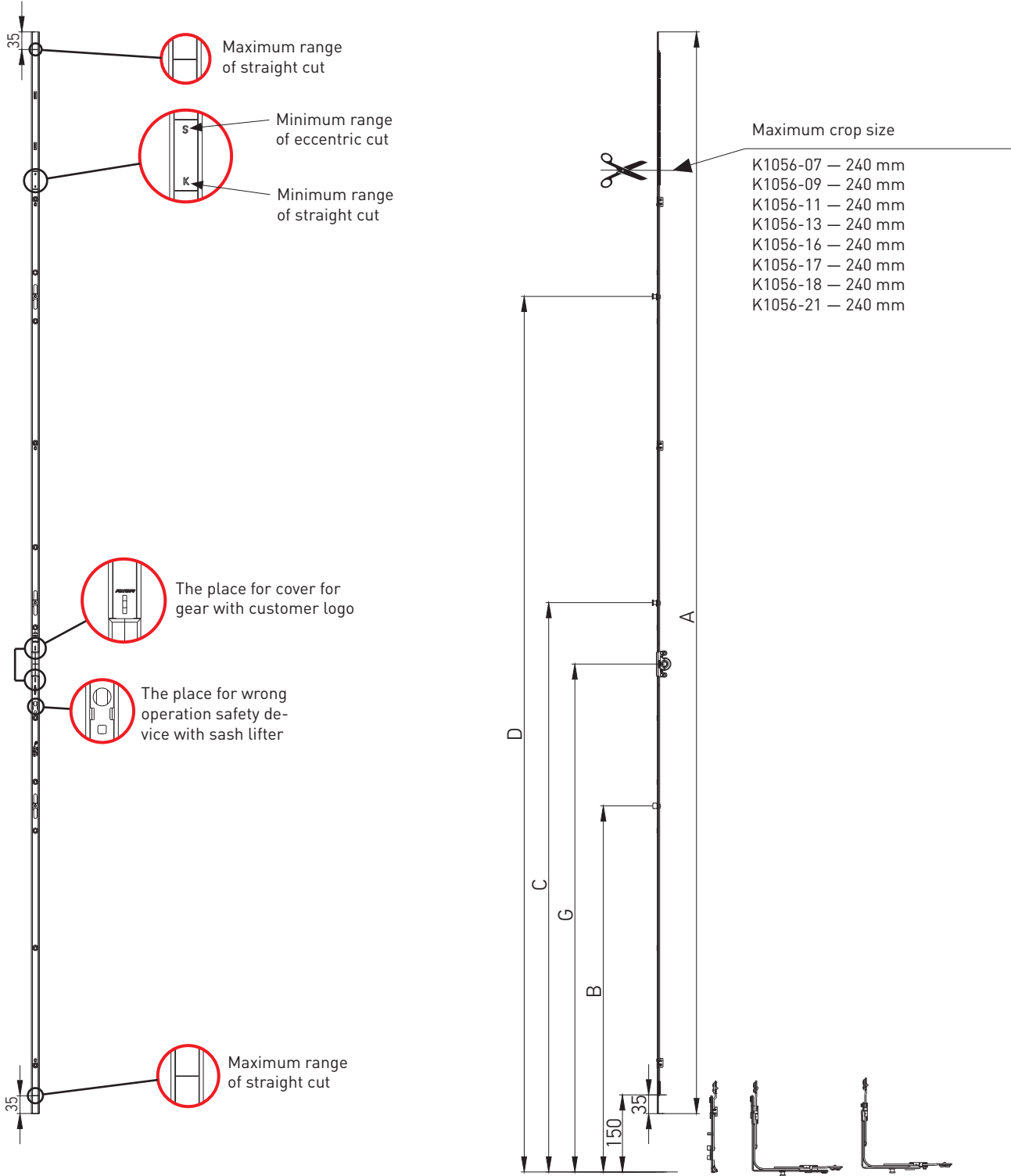

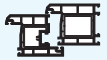
**Constant tilt & turn gear**

## Gears

Description	SRH (mm)	Dimensions								Part No.
		G	A	B	C	D				
Constant gear 2 L=690, G=300, 681-920, MR*	681-920	300	690	—	431	—	1	3	20	K1056-07-N03
Constant gear 3, L=930, G=450, 921-1160, MR	921-1160	450	930	—	571	—	1	4	20	K1056-09-N03
Constant gear 4, L=1170, G=600, 1161-1400, MR	1161-1400	600	1170	—	721	—	1	6	20	K1056-11-N03
Constant gear 5, L=1410, G=600, 1401-1640, MR	1401-1640	600	1410	—	721	1039	2	7	20	K1056-13-N03
Constant gear 6, L=1650, G=600, 1641-1880, MR	1641-1880	600	1650	—	721	1244	2	8	10	K1056-16-N03
Constant gear 7, L=1650, G=1000, 1641-1880, MR	1641-1880	1000	1650	721	1264	—	2	8	10	K1056-17-N03
Constant gear 8, L=1890, G=1000, 1881-2120, MR	1881-2120	1000	1890	721	1388	—	2	9	10	K1056-18-N03
Constant gear 9, L=2130, G=1000, 2121-2360, MR	2121-2360	1000	2130	721	1121	1724	3	11	10	K1056-21-N03

\* there is not a place for the micro lift;

- Backset 15 mm.



**Constant tilt & turn gear**

Gears

Constant tilt & turn gear

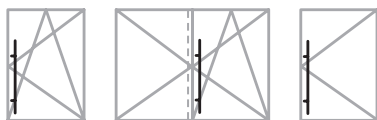
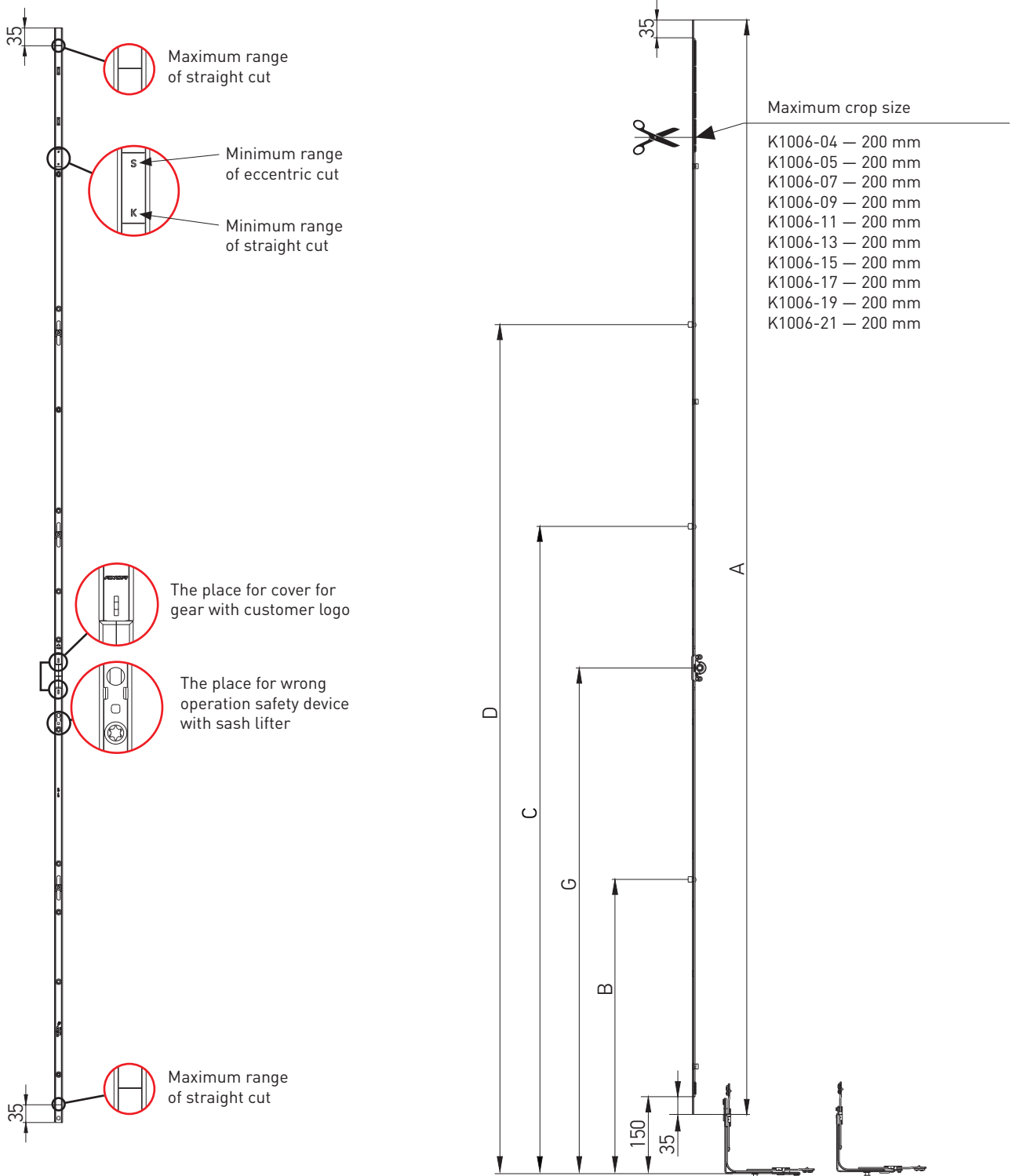

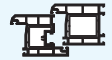

## Constant tilt &amp; turn gear

## Gears

Description	SRH (mm)	Dimensions								Part No.
		G	A	B	C	D				
Constant gear L=470, G=180, 400-600*	400-600	180	470	—	—	—	—	0	20	K1006-04-N03
Constant gear L=570, G=300, 601-800**	601-800	300	570	—	—	—	—	2	20	K1006-05-N03
Constant gear L=770, G=400, 801-1000, 1 ML	801-1000	400	770	—	480	—	1	3	20	K1006-07-N03
Constant gear L=970, G=500, 1001-1200, 1 ML	1001-1200	500	970	—	680	—	1	5	20	K1006-09-N03
Constant gear L=1170, G=500, 1201-1400, 1 ML	1201-1400	500	1170	—	680	—	1	6	20	K1006-11-N03
Constant gear L=1370, G=500, 1401-1600, 1 ML	1401-1600	500	1370	—	780	—	1	7	20	K1006-13-N03
Constant gear L=1570, G=500, 1601-1800, 2 ML	1601-1800	700	1570	—	780	1280	2	7	20	K1006-15-N03
Constant gear L=1770, G=1000, 1801-2000, 2 ML	1801-2000	1000	1770	780	1280	—	2	10	10	K1006-17-N03
Constant gear L=1970, G=1000, 2001-2200, 2 ML	2001-2200	1000	1970	780	1580	—	2	11	10	K1006-19-N03
Constant gear L=2170, G=1000, 2201-2400, 3 ML	2201-2400	1000	2170	580	1280	1680	3	11	10	K1006-21-N03

\* connecting with narrow corner transmission

\*\* there is not a place for the micro lift



**Tilt and turn variable gear  
handle position is central**

Gears

Tilt and turn variable gear, handle position is central, backset 7,5 mm.

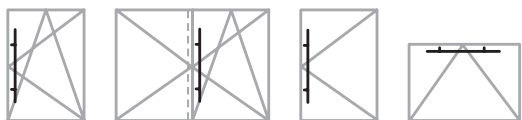
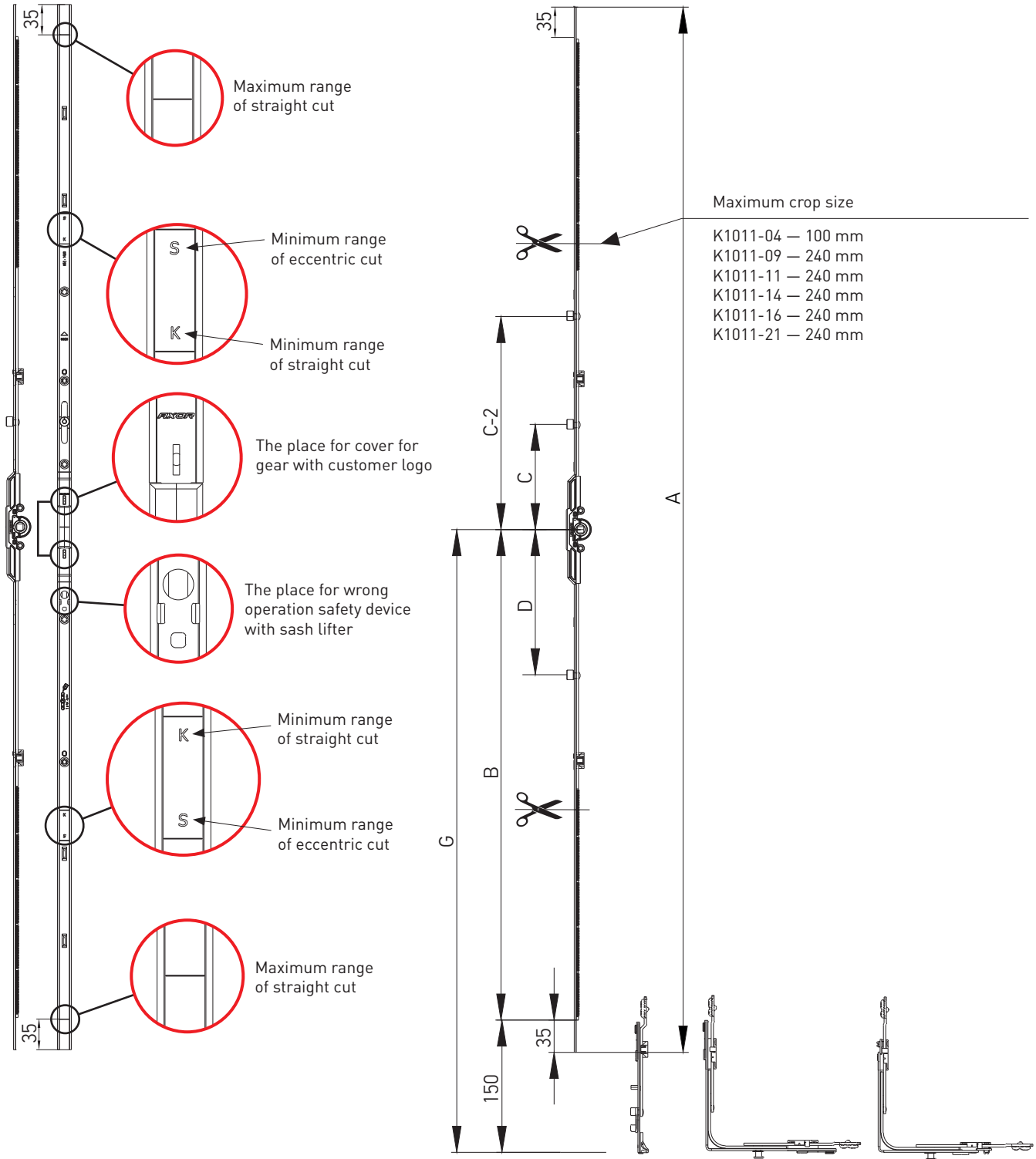



## Tilt and turn variable gear handle position is central

## Gears

Description	SRH (mm)	Dimensions										Part No.
		G	A	B	C	C-2	D					
Gear variable L= 520, 551-750, backset 7,5 mm* **	551-750	275-375	520	225	—	—	—	—	—	2	20	K1011-04-N03
Gear variable L= 1000, 751-1230, 1 ML, backset 7,5 mm**	751-1230	375-615	1000	465	120	—	—	1	—	4	20	K1011-09-N03
Gear variable L= 1200, 950-1430, 1 ML, backset 7,5 mm	950-1430	475-715	1200	565	120	—	—	1	—	5	20	K1011-11-N03
Gear variable L= 1480, 1231-1710, 2 ML, backset 7,5 mm	1231-1710	615-855	1480	705	120	—	290	2	—	6	10	K1011-14-N03
Gear variable L= 1680, 1431-1910, 2 ML, backset 7,5 mm	1431-1910	715-955	1680	805	265	—	390	2	—	7	10	K1011-16-N03
Gear variable L= 2160, 1911-2390, 3 ML, backset 7,5 mm	1911-2390	955-1195	2160	1045	120	595	490	3	—	11	10	K1011-21-N03
Gear variable L= 1000, 751-1230, 1 MR, backset 7,5 mm**	751-1230	375-615	1000	465	120	—	—	—	1	4	20	K1041-09-N03
Gear variable L= 1200, 950-1430, 1 MR, backset 7,5 mm	950-1430	475-715	1200	565	120	—	—	—	1	5	20	K1041-11-N03
Gear variable L= 1480, 1231-1710, 2 MR, backset 7,5 mm	1231-1710	615-855	1480	705	120	—	290	—	2	6	20	K1041-14-N03
Gear variable L= 1680, 1431-1910, 2 MR, backset 7,5 mm	1431-1910	715-955	1680	805	265	—	390	—	2	7	10	K1041-16-N03
Gear variable L= 2160, 1911-2390, 3 MR, backset 7,5 mm	1911-2390	955-1195	2160	1045	120	595	490	—	3	11	10	K1041-21-N03

\* there is not a place for the micro lift;

\*\* not used for double sash windows



**Tilt and turn variable gear  
handle position is central**

Gears

Tilt and turn variable gear, handle position is central, backset 25, 30, 35 mm.

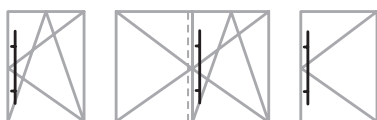
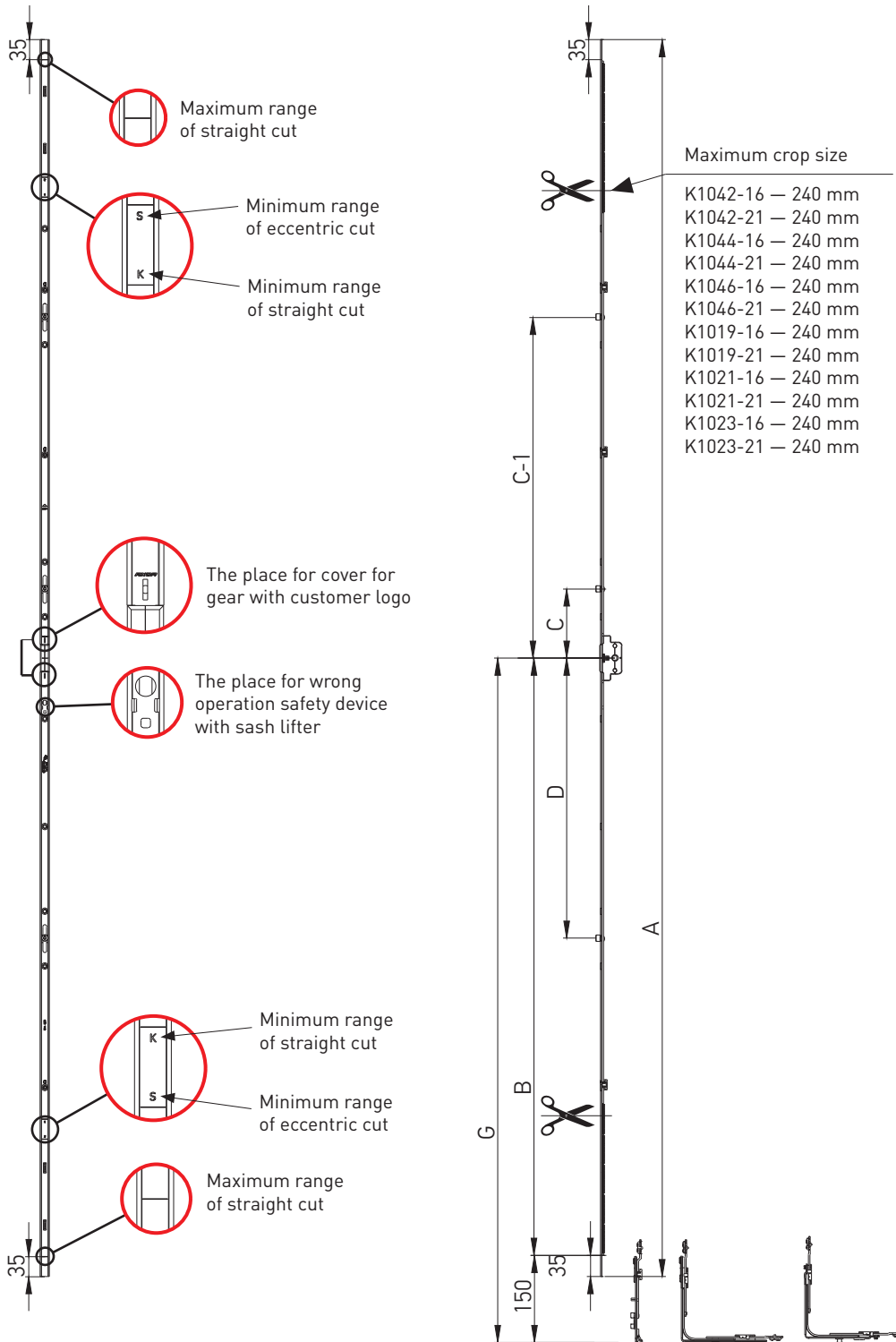



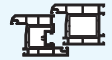

## Tilt and turn variable gear handle position is central

## Gears

Description	SRH (mm)	Dimensions									Part No.
		A	B	C	C-1	D	G				
Gear variable L= 1680, 1431-1910, backset 25 mm*, 2 ML	1431-1910	1680	805	—	265	390	715-955	2	7	10	K1042-16-N03
Gear variable L= 2160, 1911-2390, backset 25 mm*, 3 ML	1911-2390	2160	1045	120	595	490	955-1195	3	11	10	K1042-21-N03
Gear variable L= 1680, 1431-1910, backset 30 mm*, 2 ML	1431-1910	1680	805	—	265	390	715-955	2	7	10	K1044-16-N03
Gear variable L= 2160, 1911-2390, backset 30 mm*, 3 ML	1911-2390	2160	1045	120	595	490	955-1195	3	11	10	K1044-21-N03
Gear variable L= 1680, 1431-1910, backset 35 mm*, 2 ML	1431-1910	1680	805	—	265	390	715-955	2	7	10	K1046-16-N03
Gear variable L= 2160, 1911-2390, backset 35 mm*, 3 ML	1911-2390	2160	1045	120	595	490	955-1195	3	11	10	K1046-21-N03
Gear variable L= 1680, 1431-1910, backset 25 mm**, 2 ML	1431-1910	1680	805	—	265	390	715-955	2	7	10	K1019-16-N03
Gear variable L= 2160, 1911-2390, backset 25 mm**, 3 ML	1911-2390	2160	1045	120	595	490	955-1195	3	11	10	K1019-21-N03
Gear variable L= 1680, 1431-1910, backset 30 mm**, 2 ML	1431-1910	1680	805	—	265	390	715-955	2	7	10	K1021-16-N03
Gear variable L= 2160, 1911-2390, backset 30 mm**, 3 ML	1911-2390	2160	1045	120	595	490	955-1195	3	11	10	K1021-21-N03
Gear variable L= 1680, 1431-1910, backset 35 mm**, 2 ML	1431-1910	1680	805	—	265	390	715-955	2	7	10	K1023-16-N03
Gear variable L= 2160, 1911-2390, backset 35 mm**, 3 ML	1911-2390	2160	1045	120	595	490	955-1195	3	11	10	K1023-21-N03

\* 2-side handle, locking parts with through holes with a diameter of 6.5 mm;

\*\* locking parts with threaded holes M5.

- handle position is central.



# Tilt and turn variable gear

Gears

Tilt and turn variable gear, the handle position is constant, backset 7,5 mm.

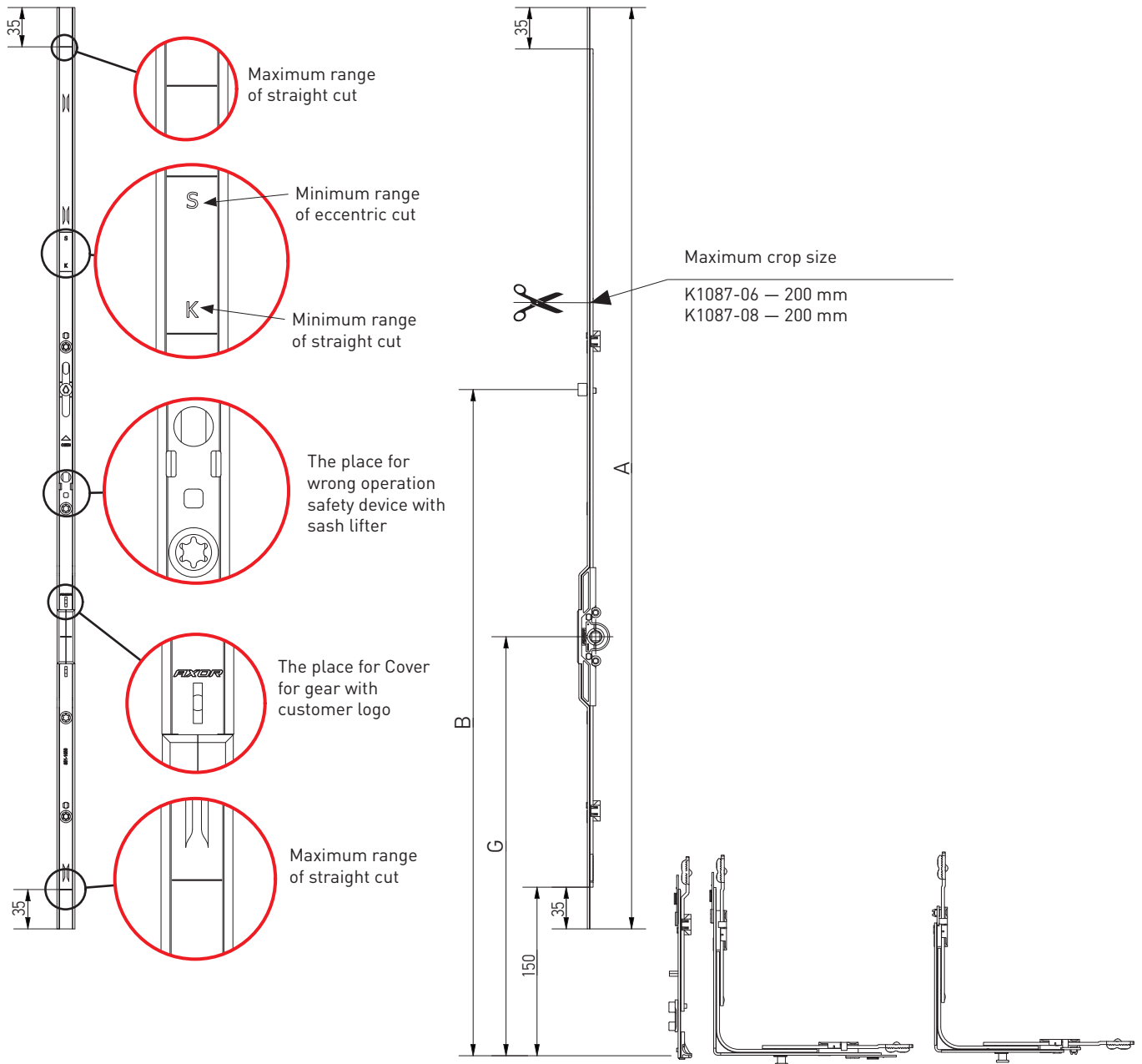

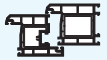

**Tilt and turn variable gear**

## Gears

Description	SRH (mm)	Dimensions						Part No.
		A	B	G				
Gear variable L= 620, 650-850, backset 7,5 mm	650-850	620	805	—	—	3	20	K1087-06-N03
Gear variable L= 820, 851-1050, backset 7,5 mm, 1 ML	851-1050	820	595	375	1	4	20	K1087-08-N03

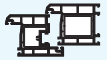



## Tilt and turn variable gear PZ

### Gears

Description	SRH (mm)	Dimensions										Part No.
		A	B	C	C-1	D	G	X				
Gear variable L= 1680, 1431-1910, backset 25 mm*, 2 ML	1431-1910	1680	805	—	265	390	715-955	200	2	7	10	K1043-16-N03
Gear variable L= 2160, 1911-2390, backset 25 mm*, 3 ML	1911-2390	2160	1045	120	595	490	955-1195	200	3	11	10	K1043-21-N03
Gear variable L= 1680, 1431-1910, backset 30 mm*, 2 ML	1431-1910	1680	805	—	265	390	715-955	200	2	7	10	K1045-16-N03
Gear variable L= 2160, 1911-2390, backset 30 mm*, 3 ML	1911-2390	2160	1045	120	595	490	955-1195	200	3	11	10	K1045-21-N03
Gear variable L= 1680, 1431-1910, backset 35 mm*, 2 ML	1431-1910	1680	805	—	265	390	715-955	200	2	7	10	K1047-16-N03
Gear variable L= 2160, 1911-2390, backset 35 mm*, 3 ML	1911-2390	2160	1045	120	595	490	955-1195	200	3	11	10	K1047-21-N03
Gear variable L= 1680, 1431-1910, backset 25 mm**, 2 ML	1431-1910	1680	805	—	265	390	715-955	200	2	7	10	K1020-16-N03
Gear variable L= 2160, 1911-2390, backset 25 mm**, 3 ML	1911-2390	2160	1045	120	595	490	955-1195	200	3	11	10	K1020-21-N03
Gear variable L= 1680, 1431-1910, backset 30 mm**, 2 ML	1431-1910	1680	805	—	265	390	715-955	200	2	7	10	K1022-16-N03
Gear variable L= 2160, 1911-2390, backset 30 mm**, 3 ML	1911-2390	2160	1045	120	595	490	955-1195	200	3	11	10	K1022-21-N03
Gear variable L= 1680, 1431-1910, backset 35 mm**, 2 ML	1431-1910	1680	805	—	265	390	715-955	200	2	7	10	K1024-16-N03
Gear variable L= 2160, 1911-2390, backset 35 mm**, 3 ML	1911-2390	2160	1045	120	595	490	955-1195	200	3	11	10	K1024-21-N03

\* 2-side handle, locking parts with through holes with a diameter of 6.5 mm;  
 \*\* locking parts with threaded holes M5.

- lockable;
- handle position is central.



# Turn gear

Turn gear

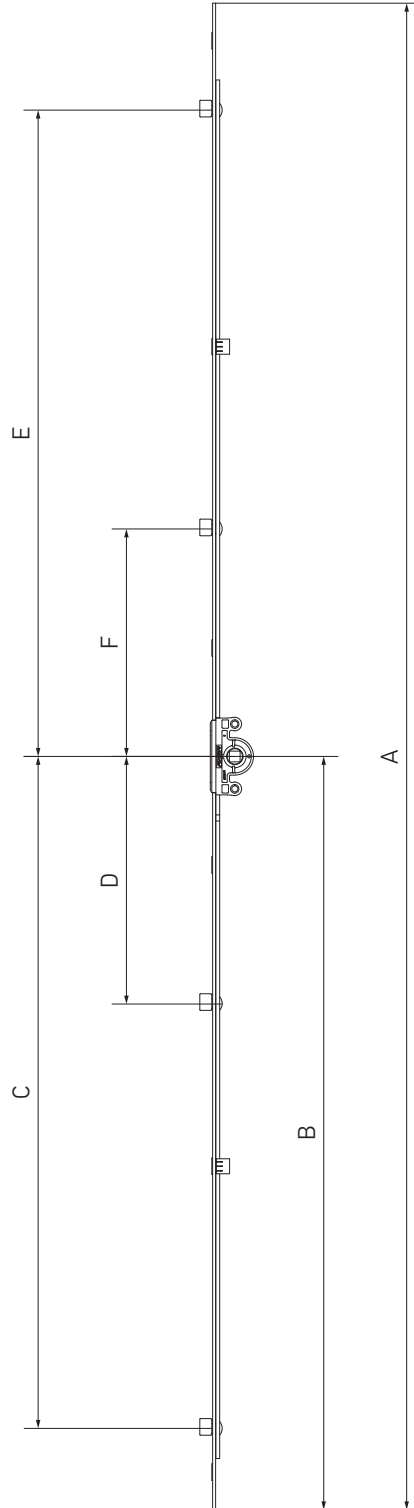



## Turn gear

## Gears

Description	SRH (mm)	Dimensions										Part No.
		A	B	C	D	E	F					
Turn gear 1 L=300, 300 - 500, 2 ML	300-500	300	150	96	—	79	—	2	—	2	20	K1003-03-N03
Turn gear 2 L=400, 401 - 600, 2 ML	401-600	400	200	146	—	129	—	2	—	2	20	K1003-04-N03
Turn gear 3 L=600, 601 - 800, 2 ML	601-800	600	300	246	—	229	—	2	—	4	20	K1003-06-N03
Turn gear 4 L=800, 801 - 1000, 2 ML	801-1000	800	400	346	—	329	—	2	—	4	20	K1003-08-N03
Turn gear 5 L=1000, 1001 - 1200, 3 ML	1001-1200	1000	500	446	—	429	101	3	—	8	20	K1003-10-N03
Turn gear 6 L=1200, 1201 - 1400, 3 ML	1201-1400	1200	600	546	—	530	101	3	—	8	20	K1003-12-N03
Turn gear 7 L=1400, 1401 - 1600, 3 ML	1401-1600	1400	700	646	—	629	101	3	—	8	20	K1003-14-N03
Turn gear 8 L=1600, 1601 - 1800, 4 ML	1601-1800	1600	800	746	318	729	301	4	—	8	10	K1003-16-N03
Turn gear 9 L=1800, 1801 - 2000, 4 ML	1801-2000	1800	900	846	318	829	301	4	—	10	10	K1003-18-N03
Turn gear 10 L=2000, 2001 - 2200, 4 ML	2001-2200	2000	1000	946	318	929	301	4	—	10	10	K1003-20-N03
Turn gear 11 L=2200, 2201 - 2400, 4 ML	2201-2400	2200	1100	1046	318	1029	301	4	—	11	10	K1003-22-N03
Turn gear 1 L=300, 300 - 500, 2 MR	300-500	300	150	96	—	79	—	—	2	2	20	K1033-03-N03
Turn gear 2 L=400, 401 - 600, 2 MR	401-600	400	200	146	—	129	—	—	2	2	20	K1033-04-N03
Turn gear 3 L=600, 601 - 800, 2 MR	601-800	600	300	246	—	229	—	—	2	4	20	K1033-06-N03
Turn gear 4 L=800, 801 - 1000, 2 MR	801-1000	800	400	346	—	329	—	—	2	4	20	K1033-08-N03
Turn gear 5 L=1000, 1001 - 1200, 3 MR	1001-1200	1000	500	446	—	429	101	—	3	8	20	K1033-10-N03
Turn gear 6 L=1200, 1201 - 1400, 3MR	1201-1400	1200	600	546	—	530	101	—	3	8	20	K1033-12-N03
Turn gear 7 L=1400, 1401 - 1600, 3MR	1401-1600	1400	700	646	—	629	101	—	3	8	20	K1033-14-N03
Turn gear 8 L=1600, 1601 - 1800, 4MR	1601-1800	1600	800	746	318	729	301	—	4	8	10	K1033-16-N03
Turn gear 9 L=1800, 1801 - 2000, 4MR	1801-2000	1800	900	846	318	829	301	—	4	10	10	K1033-18-N03
Turn gear 10 L=2000, 2001 - 2200, 4MR	2001-2200	2000	1000	946	318	929	301	—	4	10	10	K1033-20-N03
Turn gear 11 L=2200, 2201 - 2400, 4MR	2201-2400	2200	1100	1046	318	1029	301	—	4	11	10	K1033-22-N03

**Turn gear**

Gears

Turn gear, backset 7,5 mm.

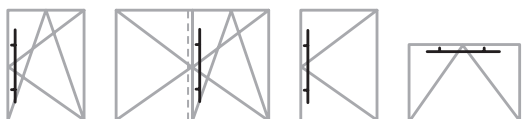
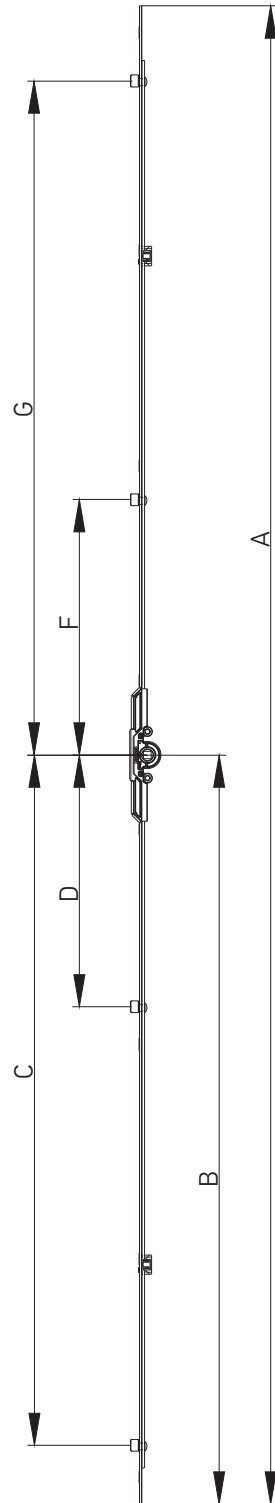
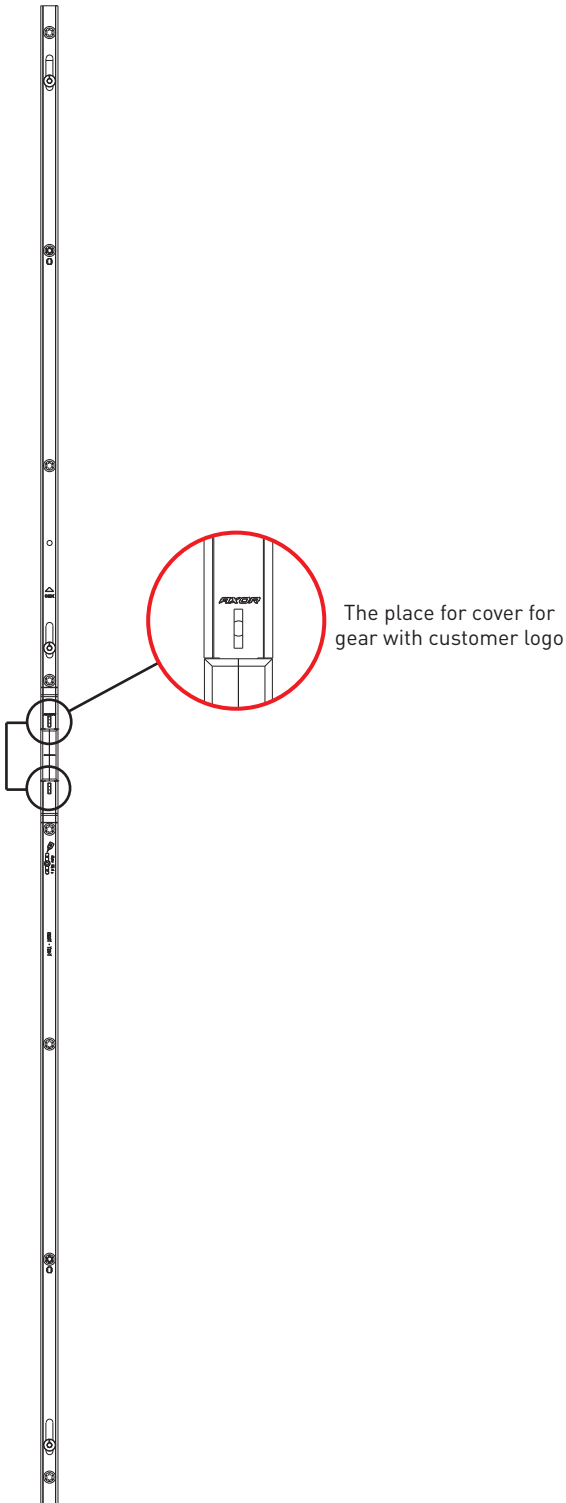





## Turn gear

## Gears

Description	SRH (mm)	Dimensions									Part No.
		A	B	C	D	F	G				
Turn gear 2, L=400, 401-600, backset 7,5 mm, 2 ML	400-600	394	197	—	143	—	126	2	4	20	K1049-04-N03
Turn gear 3, L=600, 601-800, backset 7,5 mm, 2 ML	601-800	594	297	—	243	—	226	2	4	20	K1049-06-N03
Turn gear 4, L=800, 801-1000, backset 7,5 mm, 2 ML	800-1000	794	397	—	343	—	326	2	6	20	K1049-08-N03
Turn gear 5, L=1000, 1001-1200, backset 7,5 mm, 3 ML	1001-1200	994	497	—	443	98	426	3	6	20	K1049-10-N03
Turn gear 6, L=1200, 1201-1400, backset 7,5 mm, 3 ML	1201-1400	1194	597	—	543	98	526	3	8	20	K1049-12-N03
Turn gear 7, L=1400, 1401-1600, backset 7,5 mm, 3 ML	1401-1600	1394	697	—	643	98	626	3	8	20	K1049-14-N03
Turn gear 8, L=1600, 1601-1800, backset 7,5 mm, 4 ML	1601-1800	1594	797	743	315	298	726	4	10	10	K1049-16-N03
Turn gear 9, L=1800, 1801-2000, backset 7,5 mm, 4 ML	1801-2000	1794	897	843	315	298	826	4	10	10	K1049-18-N03
Turn gear 10, L=2000, 2001-2200, backset 7,5 mm, 4 ML	2001-2200	1994	997	943	315	298	926	4	12	10	K1049-20-N03
Turn gear 11, L=2200, 2201-2400, backset 7,5 mm, 4 ML	2201-2400	2194	1097	1043	315	298	1026	4	12	10	K1049-22-N03



**Double-sash gear with integrated locking plates**

Gears

Double-sash gear with integrated locking plates (used with tilt & turn variable gear with central handle position, Part No. K1001...)

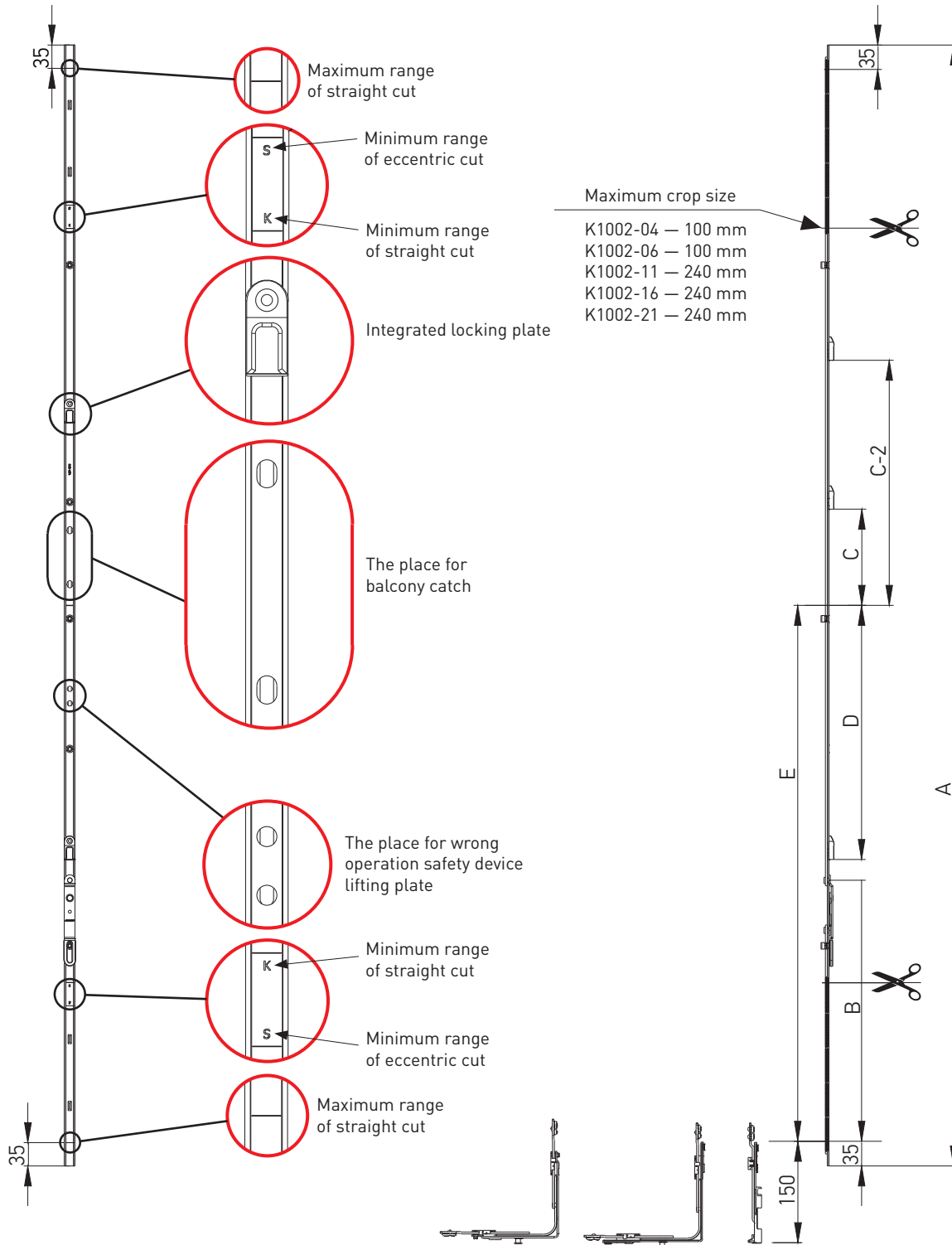

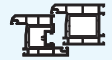

## Double-sash gear with integrated locking plates

Gears

Description	SRH (mm)	Dimensions									Part No.
		A	B	C	D	C-2	E				
Double-sash gear 1 <sup>**</sup> <sup>***</sup> L=520, 551-750	551-750	520	265	—	—	—	225	0	3	20	K1002-04-N03
Double-sash gear 2 <sup>**</sup> L=720, 751-950	751-950	720	393	129,5	—	—	325	1	4	20	K1002-06-N03
Double-sash gear 3 L=1200, 951-1430	951-1430	1200	393	129,5	—	—	565	1	6	20	K1002-11-N03
Double-sash gear 4 <sup>***</sup> L=1680, 1431-1910	1431-1910	1680	393	274,5	380,5	—	805	2	8	10	K1002-16-N03
Double-sash gear 5 <sup>***</sup> L=2160, 1911-2390	1911-2390	2160	393	129,5	480,5	604,5	1045	3	11	10	K1002-21-N03

- for double-sash profile with opposite hardware groove;
- gear with opposite motion;
- locking plates were installed.

\* there is not a place for the micro lift

\*\* not used with 7.5 mm backset

\*\*\* there is a place for balcony catch available

PERFORM THE CUT IN THE OPEN POSITION OF THE HANDLE!



**Constant double-sash gear**

Gears

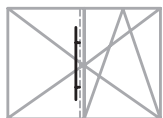
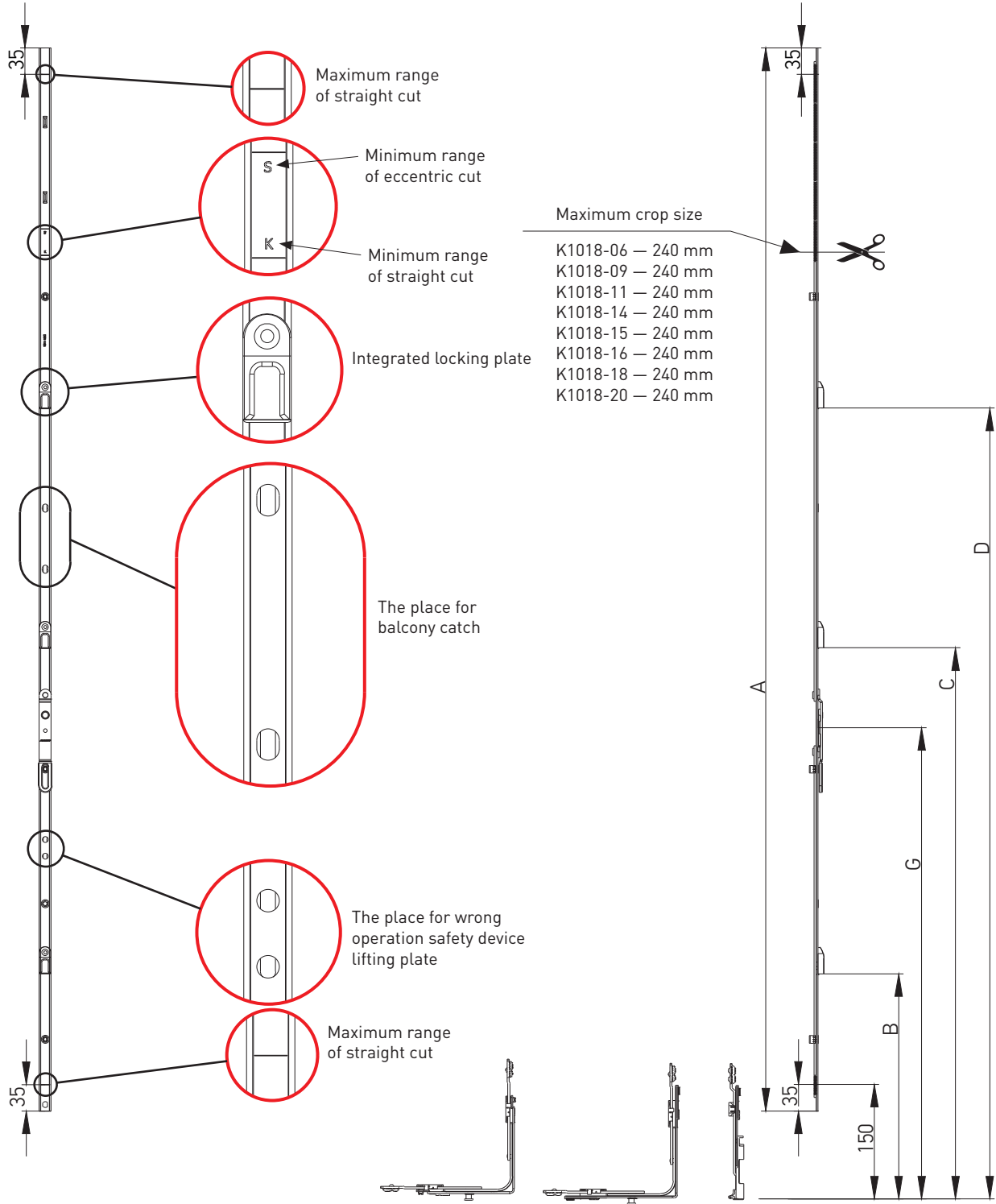

Constant double-sash gear  
(used with constant tilt & turn gear, Part No. K1004...)

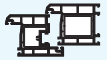



## Constant double-sash gear

### Gears

Description	SRH (mm)	Dimensions								Part No.
		G	A	B	C	D				
Constant double-sash gear G=300, L=690 mm*	681-920	300	690	—	439,5	—	1	4	20	K1018-06-N03
Constant double-sash gear G=450, L=930 mm	921-1160	450	930	—	579,5	—	1	7	20	K1018-09-N03
Constant double-sash gear G=600, L=1170 mm	1161-1400	600	1170	—	729,5	—	1	8	20	K1018-11-N03
Constant double-sash gear G=600, L=1410 mm	1401-1640	600	1410	—	729,5	1047,5	2	10	20	K1018-14-N03
Constant double-sash gear G=600, L=1650 mm	1641-1880	600	1650	—	729,5	1252,5	2	10	10	K1018-15-N03
Constant double-sash gear G=1000, L=1650 mm**	1641-1880	1000	1650	729,5	1272,5	—	2	10	10	K1018-16-N03
Constant double-sash gear G=1000, L=1890 mm**	1881-2120	1000	1890	729,5	1396,5	—	2	11	10	K1018-18-N03
Constant double-sash gear G=1000, L=2130 mm**	2121-2360	1000	2130	729,5	1129,5	1732,5	3	13	10	K1018-20-N03

- for double-sash profile with opposite hardware groove;
- gear with opposite motion;
- locking plates were installed.

\* there is not a place for the micro lift

\*\* there is a place for balcony catch available

PERFORM THE CUT IN THE OPEN POSITION OF THE HANDLE!



**Constant double-sash gear**

Gears

Constant double-sash gear  
(used with constant tilt & turn gear, Part No. K1006...)

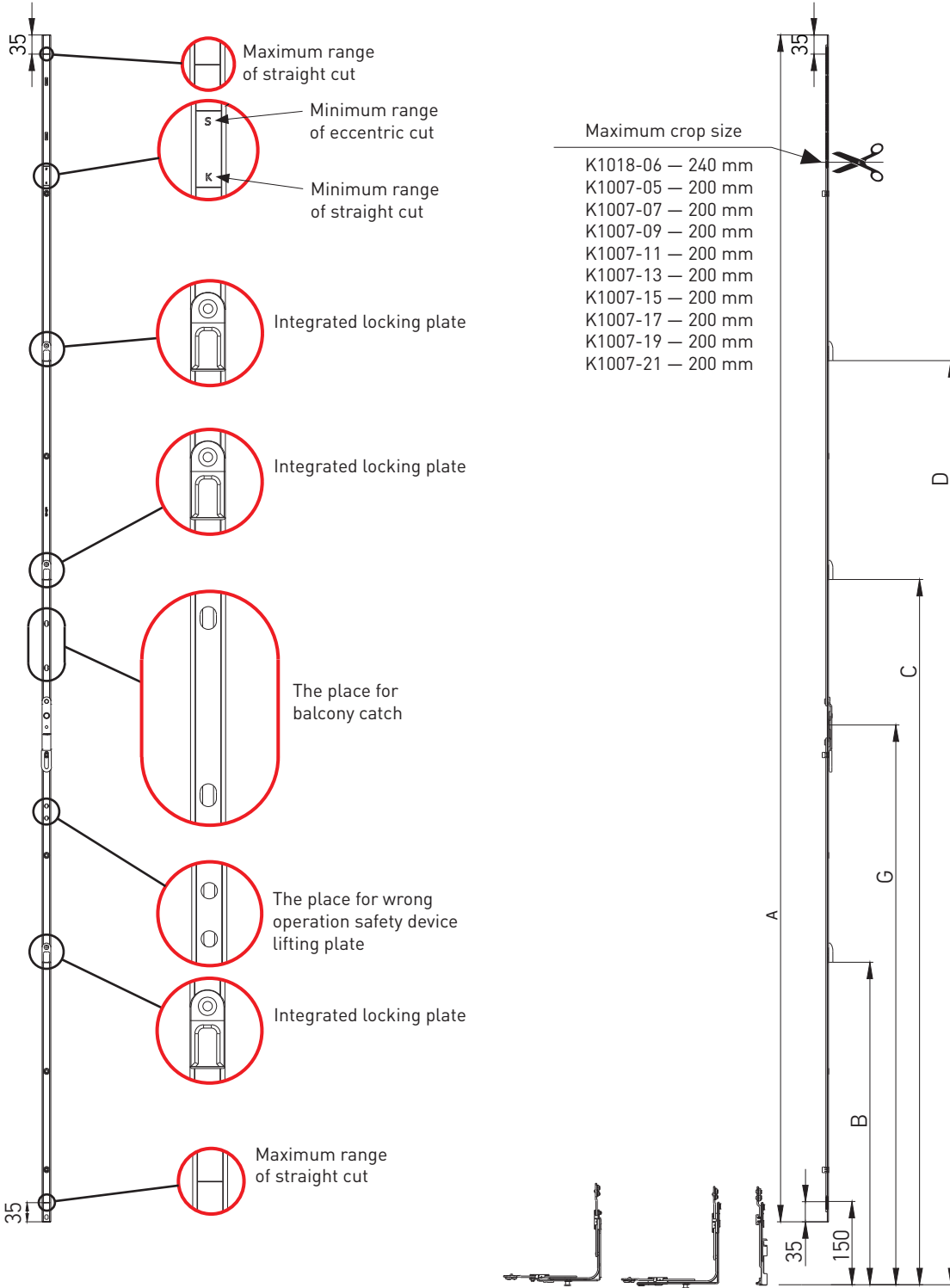



## Constant double-sash gear

### Gears

Description	SRH (mm)	Dimensions								Part No.
		G	A	B	C	D				
Constant double-sash gear L=570, G=300, 600-800*	600-800	300	570	—	—	—	—	3	20	K1007-05-N03
Constant double-sash gear L=770, G=400, 801-1000	801-1000	360	770	—	489,5	—	1	5	20	K1007-07-N03
Constant double-sash gear L=970, G=500, 1001-1200	1001-1200	500	970	—	689,5	—	1	5	20	K1007-09-N03
Constant double-sash gear L=1170, G=500, 1201-1400	1201-1400	500	1170	—	689,5	—	1	6	20	K1007-11-N03
Constant double-sash gear L=1370, G=500, 1401-1600	1401-1600	500	1370	—	789,5	—	1	7	10	K1007-13-N03
Constant double-sash gear L=1570, G=500, 1601-1800	1601-1800	400	1570	—	789,5	1289,5	2	9	10	K1007-15-N03
Constant double-sash gear L=1770, G=1000, 1801-2000**	1801-2000	1000	1770	789,5	1289,5	—	2	8	10	K1007-17-N03
Constant double-sash gear L=1970, G=1000, 2001-2200**	2001-2200	1000	1970	789,5	1589,5	—	2	9	10	K1007-19-N03
Constant double-sash gear L=2170, G=1000, 2201-2400**	2201-2400	1000	2170	589,5	1289,5	1689,5	3	10	10	K1007-21-N03

- for double-sash profile with opposite hardware groove;
- Gear with opposite motion;
- locking plates were installed.

\* there is not a place for the micro lift

\*\* there is a place for balcony catch available

PERFORM THE CUT IN THE OPEN POSITION OF THE HANDLE!



**Constant double-sash gear**

Gears

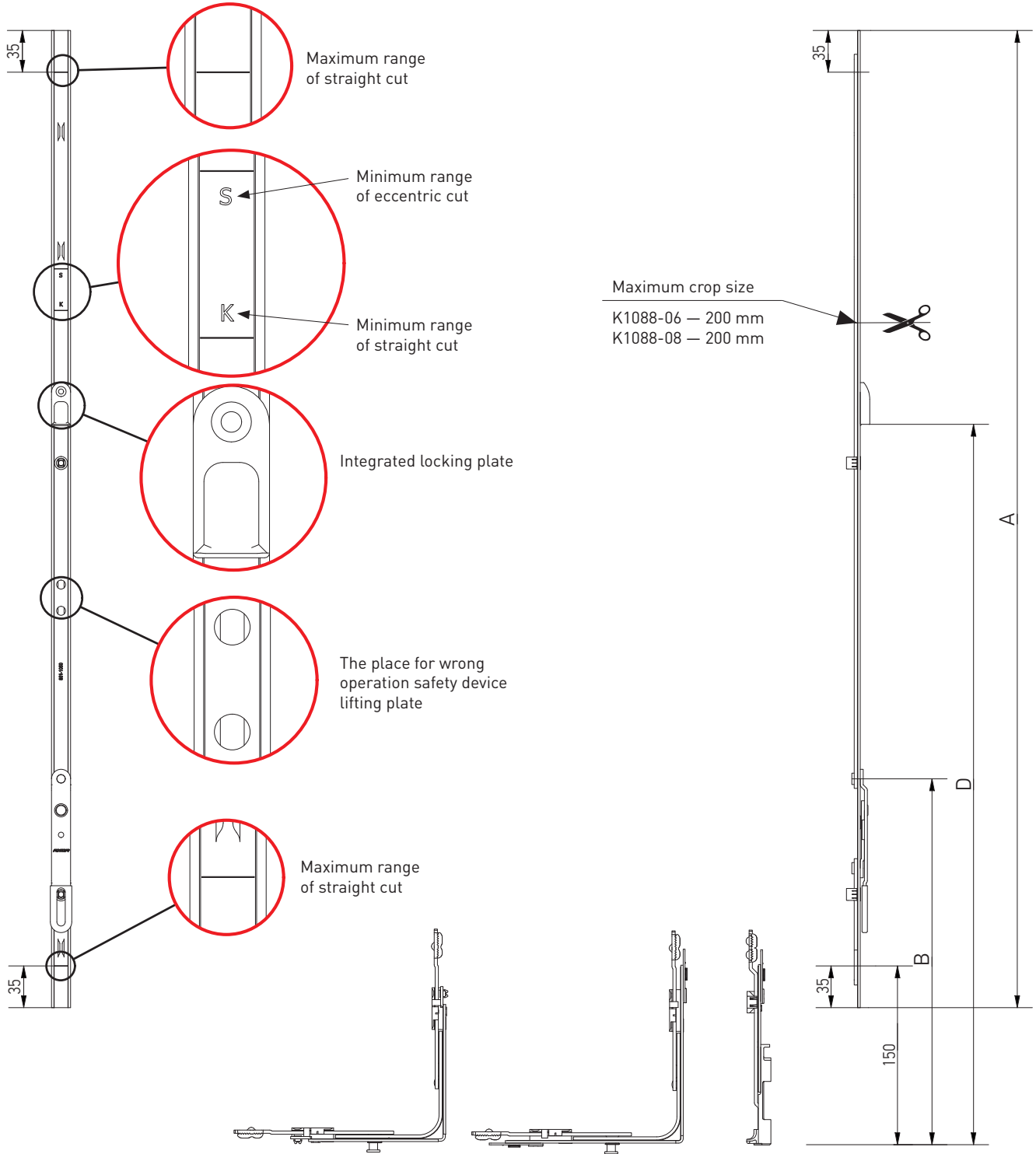

Constant double-sash gear  
(used with constant tilt & turn gear, Part No. K1087...)





**Constant double-sash gear**

Gears

Description	SRH (mm)	Dimensions						Part No.
		A	B	G				
Constant double-sash gear L= 620, 650-850	650-850	620	307	—	—	4	20	K1088-06-N03
Constant double-sash gear L= 820, 851-1050, 1 ML	851-1050	820	307	604,5	1	6	20	K1088-08-N03



**Gear for sliding system, backset 15 mm**

Gears

Gear for sliding system, backset 15 mm

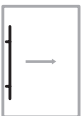
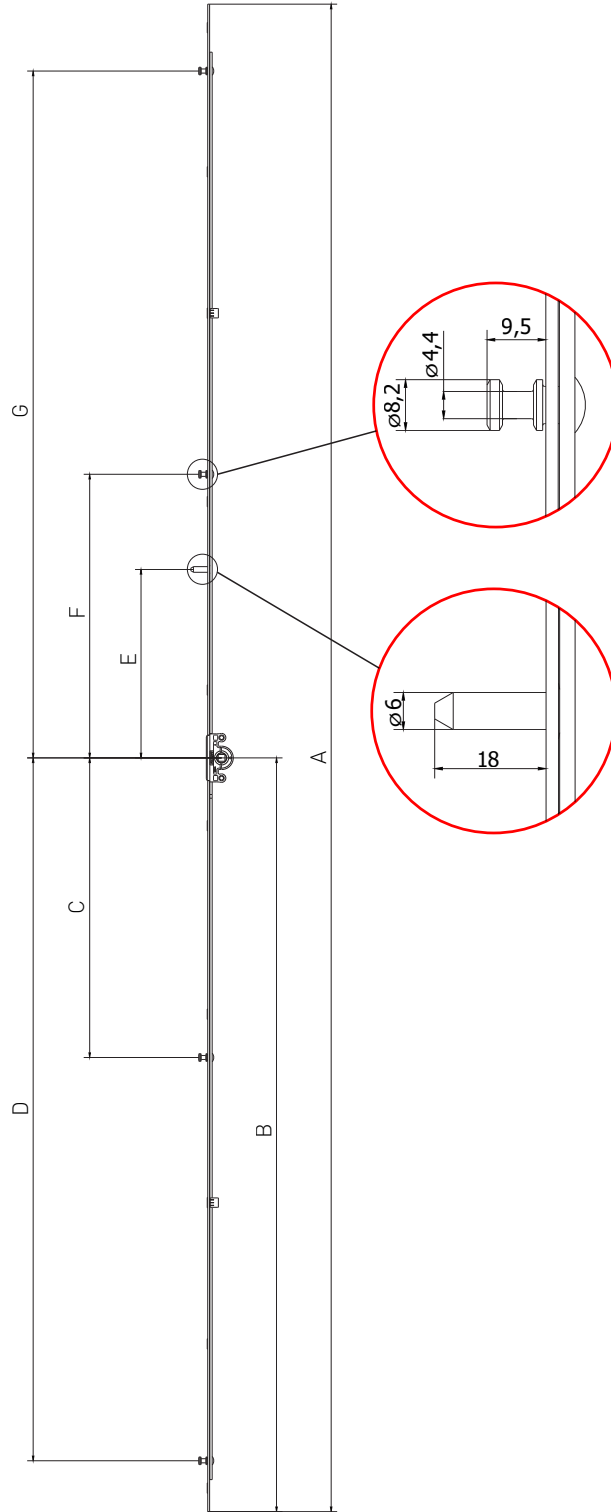



## Gear for sliding system, backset 15 mm

## Gears

Description	SRH (mm)	Dimensions									Part No.
		A	B	C	D	E	F	G			
Gear for sliding system 1, L=300, 300-400, 2 MR	300-400	300	150	—	96	49	—	79	2	3	K1005-03-N03
Gear for sliding system 2, L=400, 401-600, 2 MR	401-600	400	200	—	146	99	—	129	2	4	K1005-04-N03
Gear for sliding system 3, L=600, 601-800, 2 MR	601-800	600	300	—	246	152	—	229	2	4	K1005-06-N03
Gear for sliding system 4, L=800, 801-1000, 2 MR	800-1000	800	400	—	346	152	—	329	2	6	K1005-08-N03
Gear for sliding system 5, L=1000, 1001-1200, 3 MR	1001-1200	1000	500	—	446	200	101	429	3	6	K1005-10-N03
Gear for sliding system 6, L=1200, 1201-1400, 3 MR	1201-1400	1200	600	—	546	200	101	529	3	8	K1005-12-N03
Gear for sliding system 7, L=1400, 1401-1600, 3 MR	1401-1600	1400	700	—	646	200	101	629	3	8	K1005-14-N03
Gear for sliding system 8, L=1600, 1601-1800, 4 MR	1601-1800	1600	800	318	746	200	301	729	4	10	K1005-16-N03
Gear for sliding system 9, L=1800, 1801-2000, 4 MR	1801-2000	1800	900	318	846	200	301	829	4	10	K1005-18-N03
Gear for sliding system 10, L=2000, 2001-2200, 4 MR	2001-2200	2000	1000	318	946	200	301	929	4	12	K1005-20-N03
Gear for sliding system 11, L=2200, 2201-2400, 4 MR	2201-2400	2200	1100	318	1046	200	301	1029	4	12	K1005-22-N03



**Gear for sliding system,  
backset 7,5 mm**

Gears

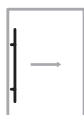
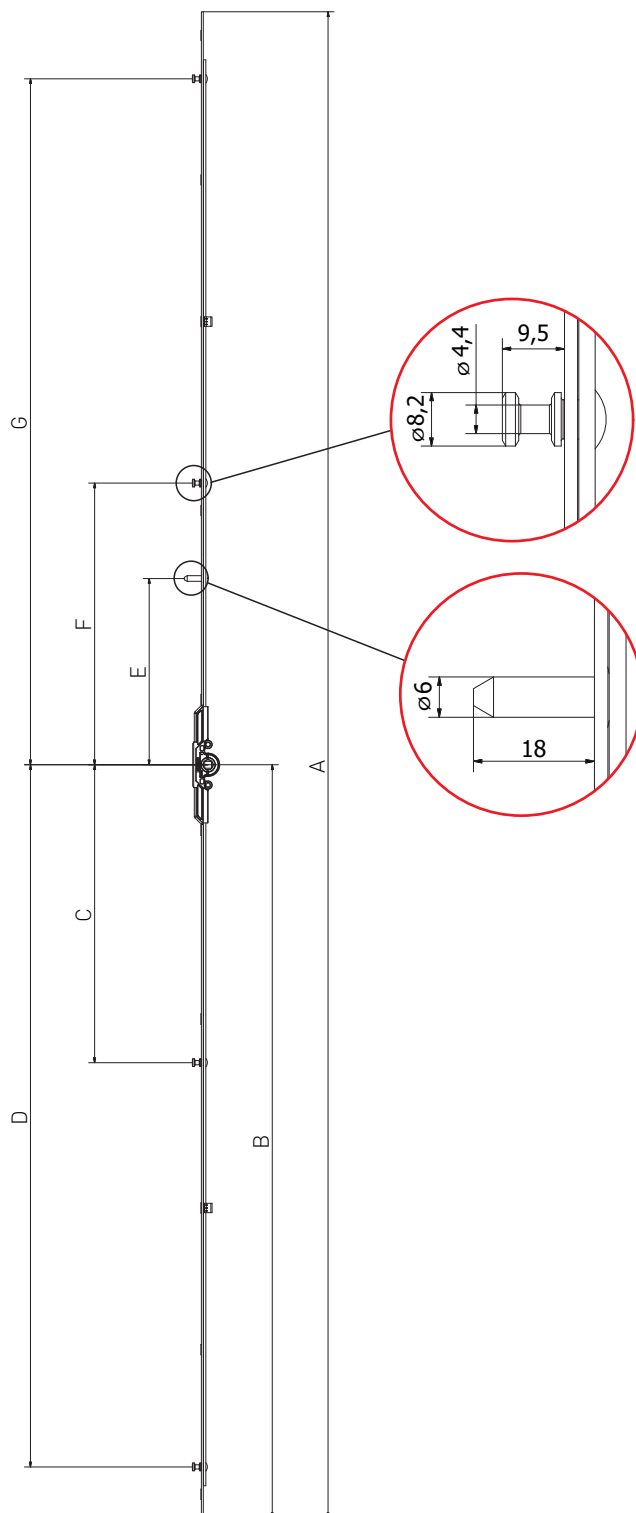
Gear for sliding system, backset 7,5 mm



**Gear for sliding system,  
backset 7,5 mm**
**Gears**

Description	SRH (mm)	Dimensions									Part No.
		A	B	C	D	E	F	G			
Gear for sliding system 2, L=400, 401-600, backset 7,5 mm, 2 MR	401-600	394	197	—	143	96	—	126	2	4	K1048-04-N03
Gear for sliding system 3, L=600, 601-800, backset 7,5 mm, 2 MR	601-800	594	297	—	243	149	—	226	2	4	K1048-06-N03
Gear for sliding system 4, L=800, 801-1000, backset 7,5 mm, 2 MR	800-1000	794	397	—	343	149	—	326	2	6	K1048-08-N03
Gear for sliding system 5, L=1000, 1001-1200, backset 7,5 mm, 3 MR	1001-1200	994	497	—	443	197	98	426	3	6	K1048-10-N03
Gear for sliding system 6, L=1200, 1201-1400, backset 7,5 mm, 3 MR	1201-1400	1194	597	—	543	197	98	526	3	8	K1048-12-N03
Gear for sliding system 7, L=1400, 1401-1600, backset 7,5 mm, 3 MR	1401-1600	1394	697	—	643	197	98	626	3	8	K1048-14-N03
Gear for sliding system 8, L=1600, 1601-1800, backset 7,5 mm, 4 MR	1601-1800	1594	797	315	743	197	298	726	4	10	K1048-16-N03
Gear for sliding system 9, L=1800, 1801-2000, backset 7,5 mm, 4 MR	1801-2000	1794	897	315	843	197	298	826	4	10	K1048-18-N03
Gear for sliding system 10, L=2000, 2001-2200, backset 7,5 mm, 4 MR	2001-2200	1994	997	315	943	197	298	926	4	12	K1048-20-N03
Gear for sliding system 11, L=2200, 2201-2400, backset 7,5 mm, 4 MR	2201-2400	2194	1097	315	1043	197	298	1026	4	12	K1048-22-N03



**Gear for sliding system  
lockable**

Gears

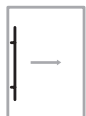
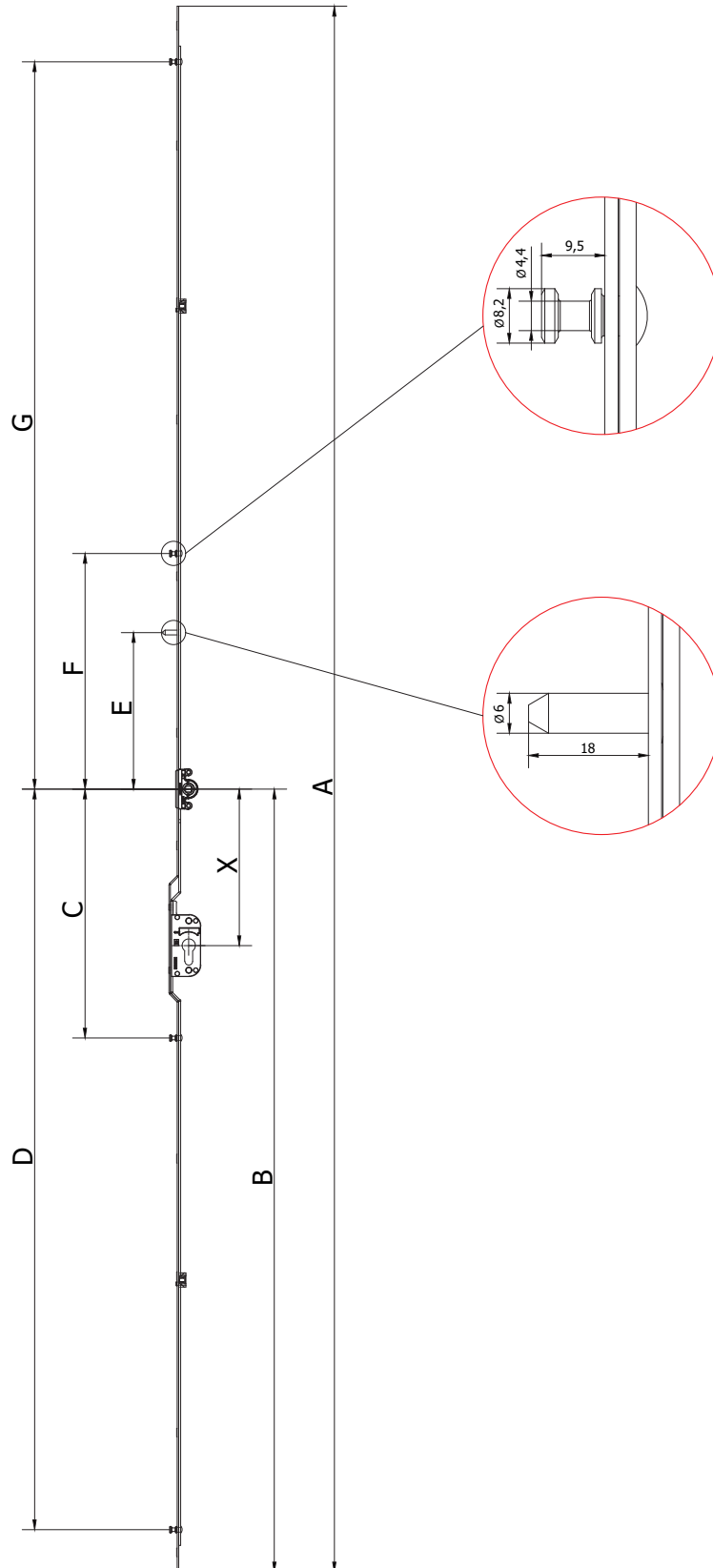

Gear for sliding system lockable, backset 15 mm.





## Gear for sliding system lockable

Gears

Description	SRH (mm)	Dimensions											Part No.
		A	B	C	D	E	F	G	X				
Gear for sliding system L=1600, 1601-1800, 4 MR	1601-1800	1600	800	318	746	200	301	729	200	4	9	10	K1074-16-N03
Gear for sliding system L=1800, 1801-2000, 4 MR	1801-2000	1800	900	318	846	200	301	829	200	4	9	10	K1074-18-N03
Gear for sliding system L=2000, 2001-2200, 4 MR	2001-2200	2000	1000	318	946	200	301	929	200	4	11	10	K1074-20-N03
Gear for sliding system L=2200, 2201-2400, 4 MR	2201-2400	2200	1100	318	1046	200	301	1029	200	4	11	10	K1074-22-N03

**AXOR**<sup>®</sup>

**KOMFORT LINE K-3**

Smart&Quick

Corner transmissions

Middle locks

Extensions

AXOR



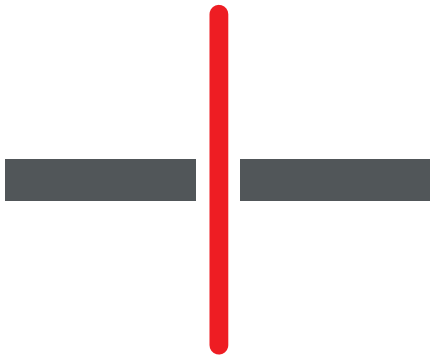

# Corner transmissions

FOR STRAIGHT CUT

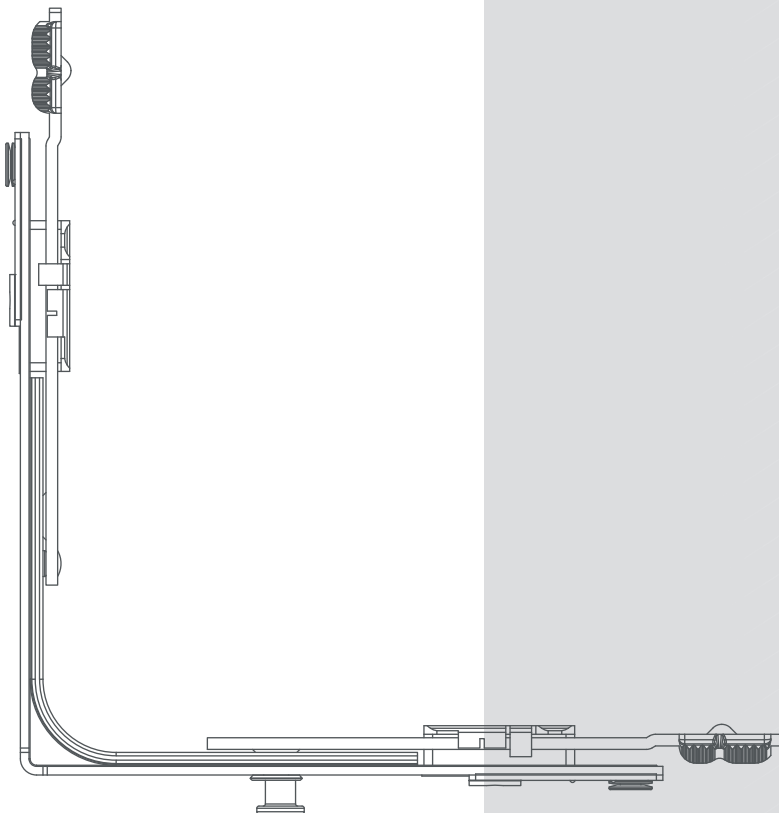

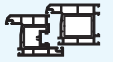

**Corner transmissions**

Corner transmissions  
Middle locks

**Corner transmission, 1 ML, 150×150**

- not intended for RC security level.

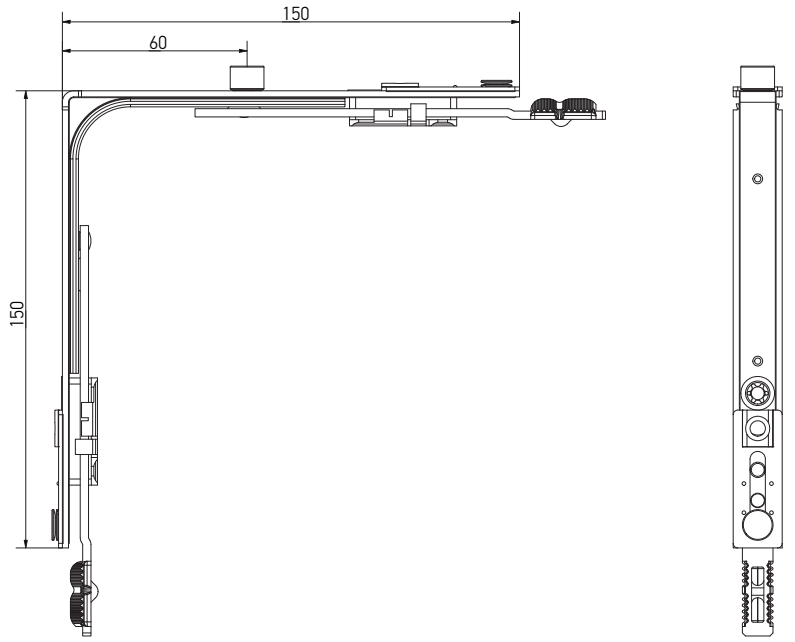
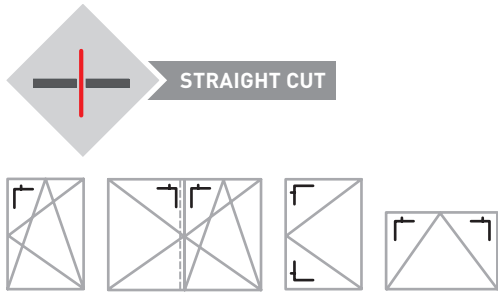

**Corner transmission, 1 MR, 150×150**

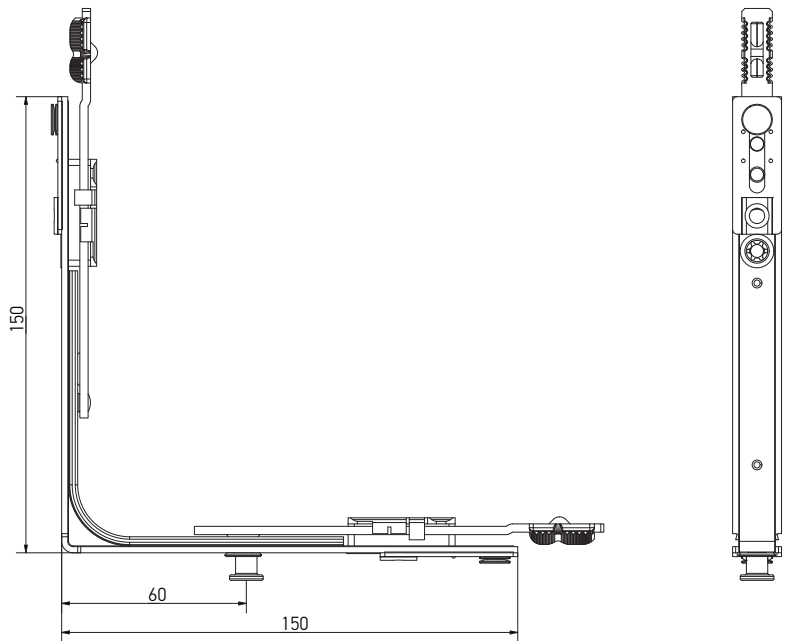
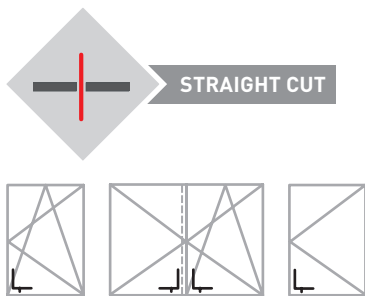

Description	Application range						Part No.
	SRW (mm)	SRH (mm)					
Corner transmission, 1 ML, 150×150	400-1280	450-2390	1	—	4	50	K2001-00-N03
Corner transmission, 1 MR, 150×150	400-1280	450-2390	—	1	4	50	K2005-00-N03
Corner transmission, 150×150, without locking pin	400-1280	450-2390	—	—	4	50	K2016-00-N03



**Corner transmissions**

Corner transmissions  
Middle locks

**Corner transmission, 2 ML, 150x150**

- not intended for RC security level.

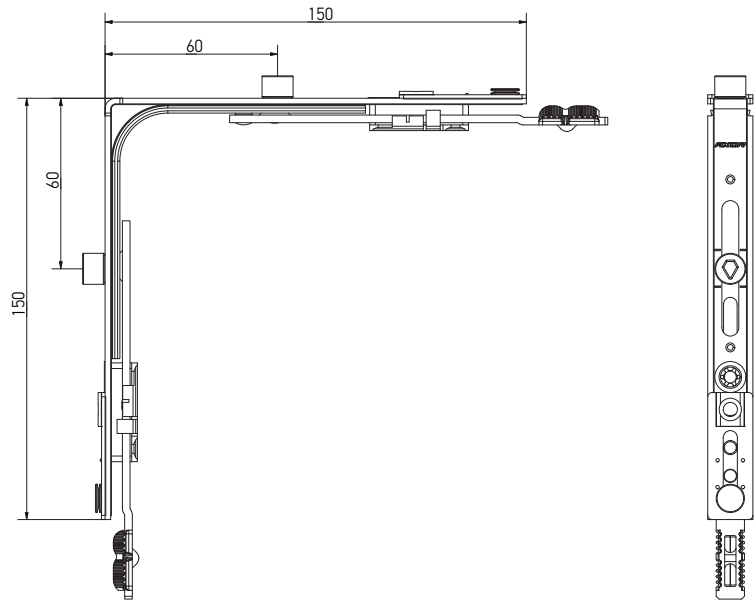
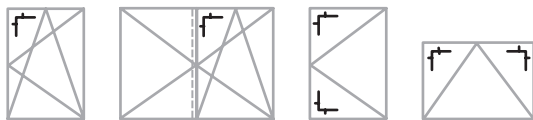
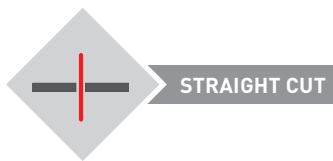

**Corner transmission, 2 MR, 150x150**

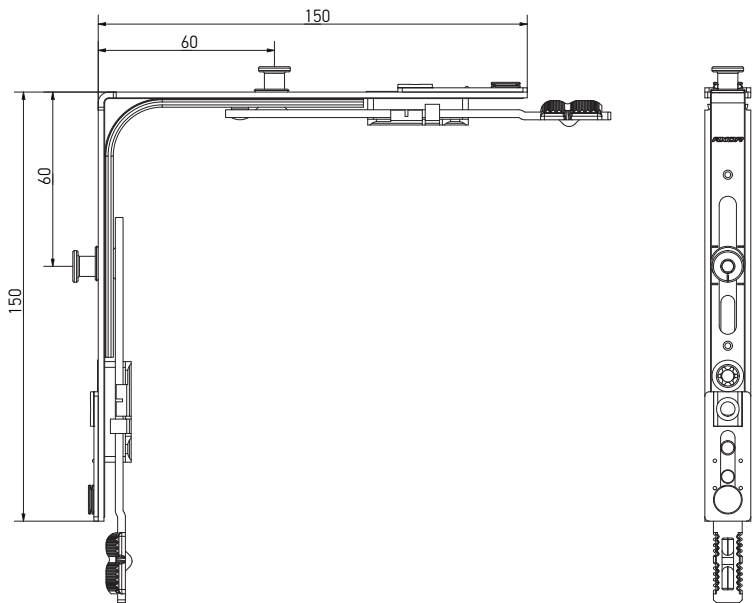
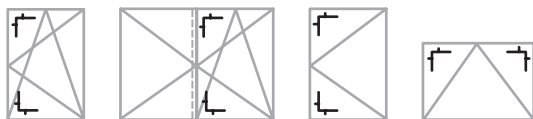
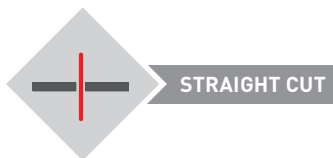

Description	Application range						Part No.
	SRW (mm)	SRH (mm)					
Corner transmission 2 ML, 150x150	400-1280	450-2390	2	—	4	50	K2002-00-N03
Corner transmission, 2 MR, 150x150	400-1280	450-2390	—	2	4	50	K2012-00-N03
Corner transmission, 1 MR, 1 ML, 150x150	400-1280	450-2390	1	1	4	50	K2013-00-N03
Corner transmission, 2 MR, 150x150, bottom	400-1280	450-2390	—	2	4	50	K2009-00-N03



**Narrow corner transmission**

Corner transmissions  
Middle locks

Narrow corner transmission, 1 ML, 50x150

Narrow corner transmission, 1 MR, 50x150

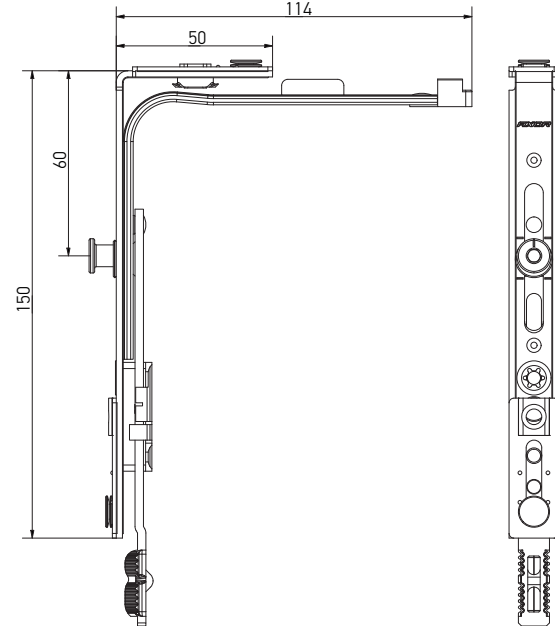
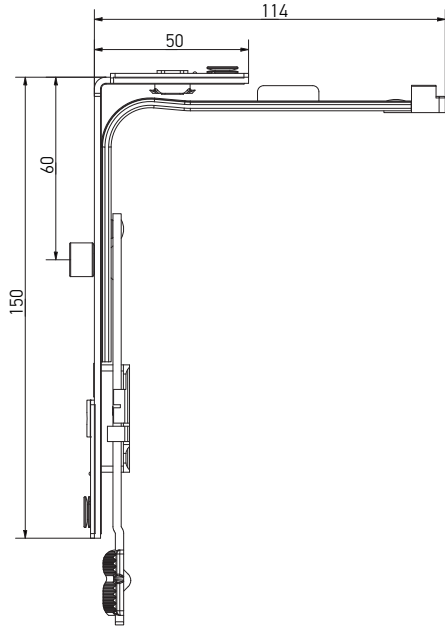

- not intended for double-sash windows;
- not intended for RC security level.

In order to use the narrow corner transmission according to scheme B the distance from the bottom of the fitting groove to the handle axis should be 225 mm, i.e. a hole for handle on gear K1001-02-N03 is displaced from the center of the sash in application range of the sash's height 370-450 mm.

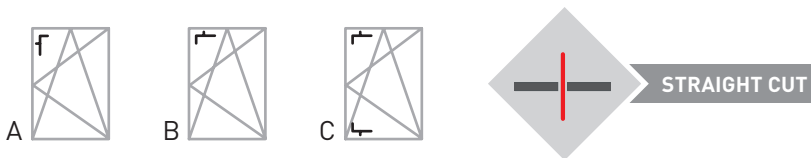

Description	Side opening	Application range						Part No.
		SRW (mm)	SRH (mm)					
Narrow corner transmission, 1 ML, 50x150	A	300-400	450-2390	1	—	3	50	K2003-00-N03
Narrow corner transmission, 1 ML, 50x150	B	400-600	370-450	1	—	3	50	K2003-00-N03
Narrow corner transmission, 1 MR, 50x150	A	300-400	450-2390	—	1	3	50	K2006-00-N03
Narrow corner transmission, 1 MR, 50x150	B	400-600	370-450	—	1	3	50	K2006-00-N03
Narrow corner transmission, 1 MR, 50x150	C	400-600	300-350	—	1	3	50	K2006-00-N03
Narrow corner transmission, without locking pin, 50x150	A	300-400	450-2390	—	—	3	50	K2017-00-N03
Narrow corner transmission, without locking pin, 50x150	B	400-600	370-450	—	—	3	50	K2017-00-N03



**Corner transmission, integrated slit**

Corner transmissions  
Middle locks

**Corner transmission, integrated slit, 1 ML, 150×150**

- separate transmissions for left and right opening;
- provides 3 type-sizes of ventilation;
- Ventilation slit 12,16, 20 mm.

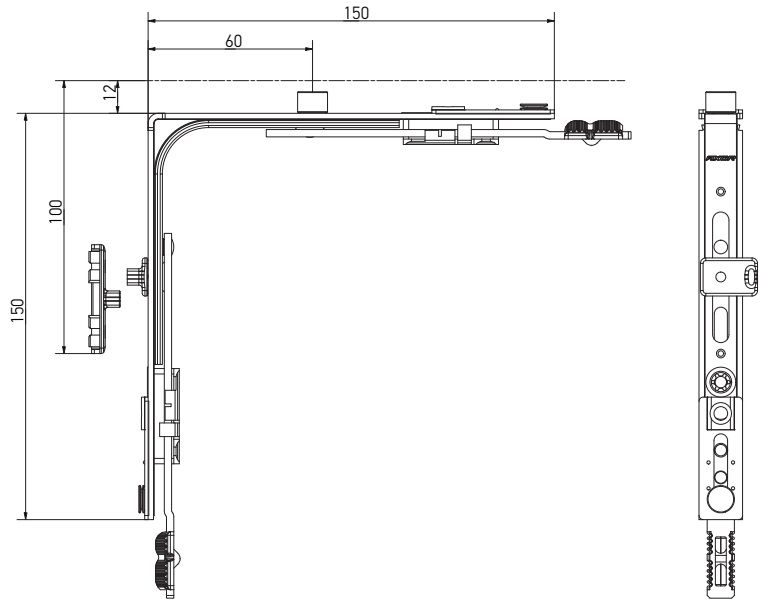

**Corner transmission, integrated slit, 1 MR, 150×150**

- separate transmissions for left and right opening;
- provides 3 type-sizes of ventilation;
- Ventilation slit 12,16, 20 mm.

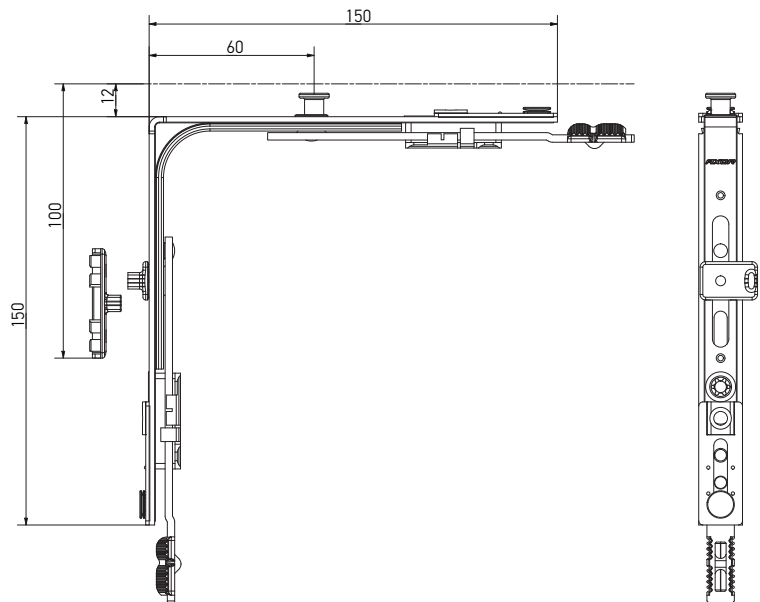

Description	Application range						Part No.
	SRW (mm)	SRH (mm)					
Corner transmission, integrated slit, 1 ML, 150×150, left	400-1280	450-2390	1	—	4	50	K2004-00-L03
Corner transmission, integrated slit, 1 ML, 150×150, right	400-1280	450-2390	1	—	4	50	K2004-00-R03
Corner transmission, integrated slit, 1 MR, 150×150, left	400-1280	450-2390	—	1	4	50	K2014-00-L03
Corner transmission, integrated slit, 1 MR, 150×150, right	400-1280	450-2390	—	1	4	50	K2014-00-R03

Locking plate for integrated slit (frame part)

look at the section “Profile-dependent elements”

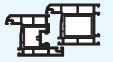

### Corner transmission, double sash, middle locks

Corner transmissions  
Middle locks

Corner transmission, double sash, 1 ML, 150×150, top

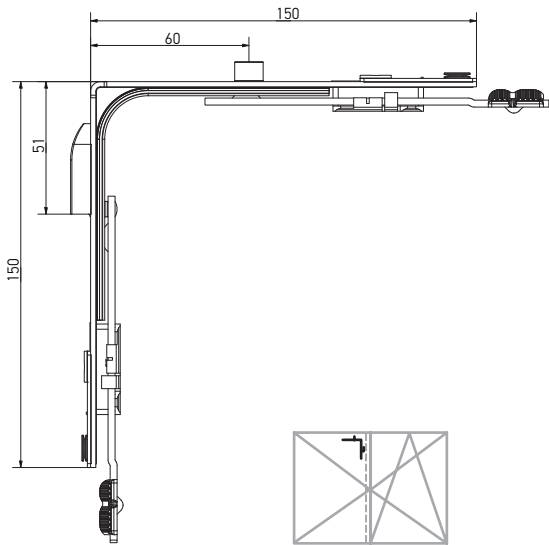

Corner transmission, double sash, 1 MR, 150×150, top

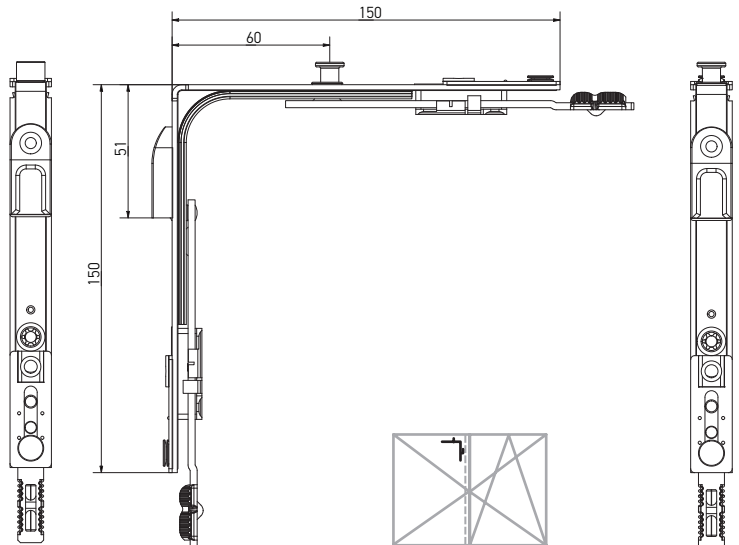

Corner transmission, double sash, 1 ML, 150×150, bottom

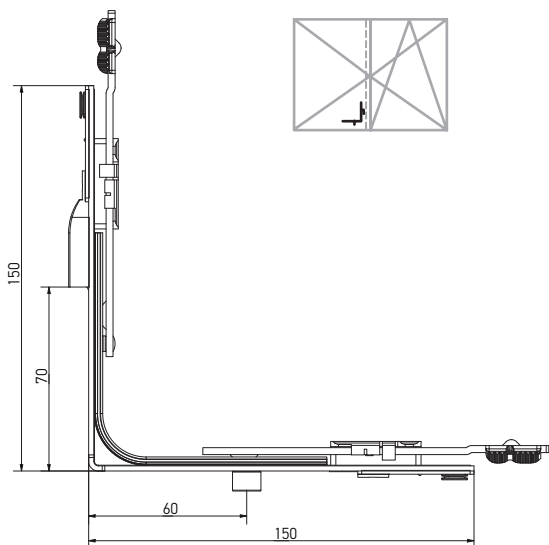

Corner transmission, double sash, 1 MR, 150×150, bottom

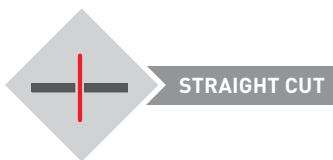
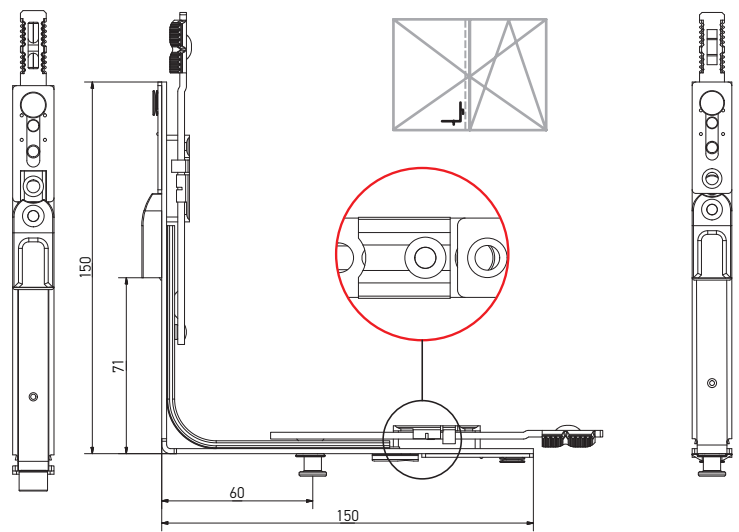

Description	Application range							Part No.
	SRW (mm)	SRH (mm)						
Corner transmission, double sash, 1 ML, 150×150, top	400-1280	450-2390	1	—	1	4	50	K2007-01-N03
Corner transmission, double sash, 1 ML, 150×150, bottom	400-1280	450-2390	1	—	1	4	50	K2007-02-N03
Corner transmission, double sash, 1 MR, 150×150, top	400-1280	450-2390	—	1	1	4	50	K2011-00-N03
Corner transmission, double sash, 1 MR, 150×150, bottom	400-1280	450-2390	—	1	1	4	50	K2010-00-N03



**Corner transmission**

Corner transmissions  
Middle locks

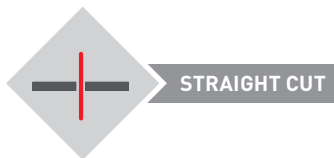
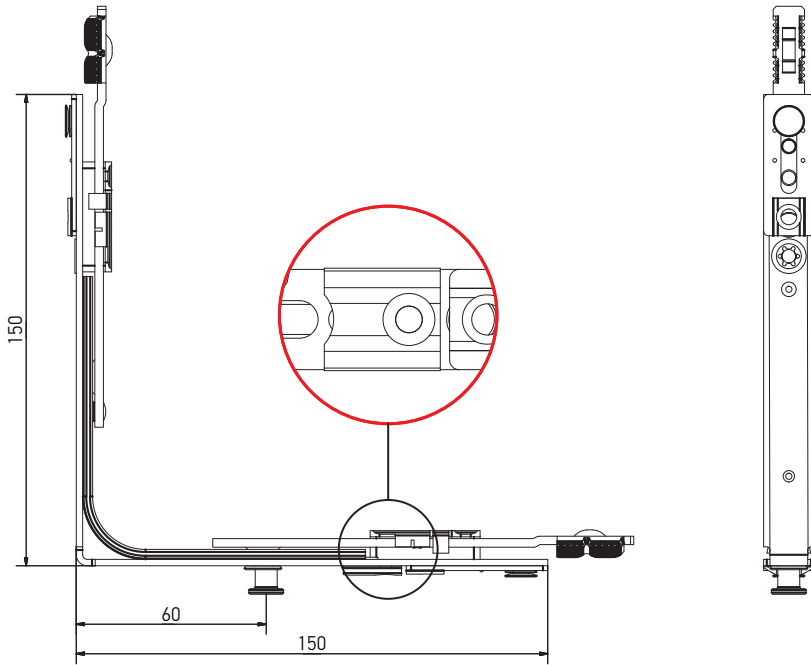

Description	Application range					Part No.
	SRW (mm)	SRH (mm)				
Corner transmission, 1 MR, 150×150, bottom	400-1280	450-2390	1	4	50	K2008-00-N03



Corner transmission for aluminium doorstep, 1 MR, 150×150

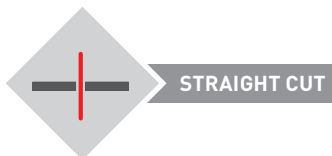
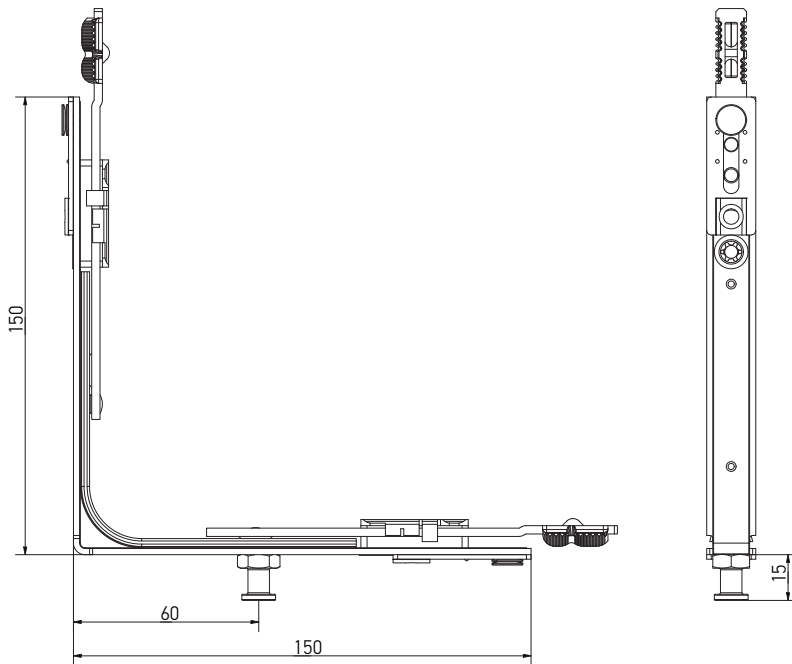

Description	Application range					Part No.
	SRW (mm)	SRH (mm)				
Corner transmission for aluminium doorstep, 1 MR, 150×150	400-1280	450-2390	1	4	50	K2015-00-N03



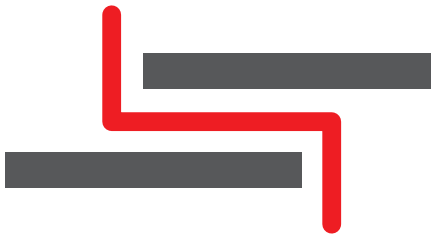

# Corner transmissions

FOR ECCENTRIC CUT

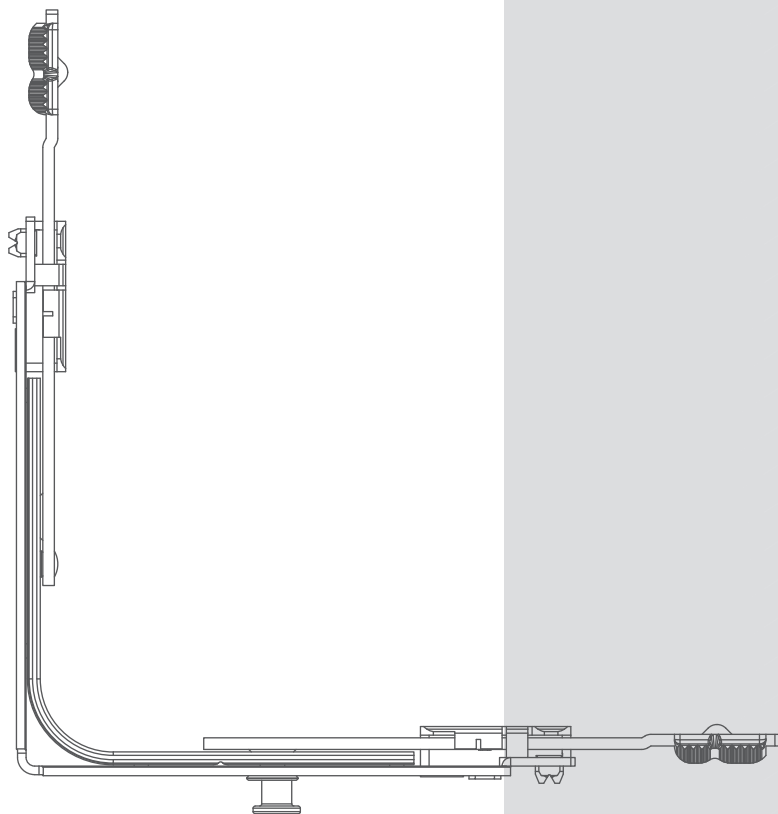

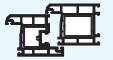

**Corner transmissions**

Corner transmissions  
Middle locks

Corner transmission, 1 ML, 115×115

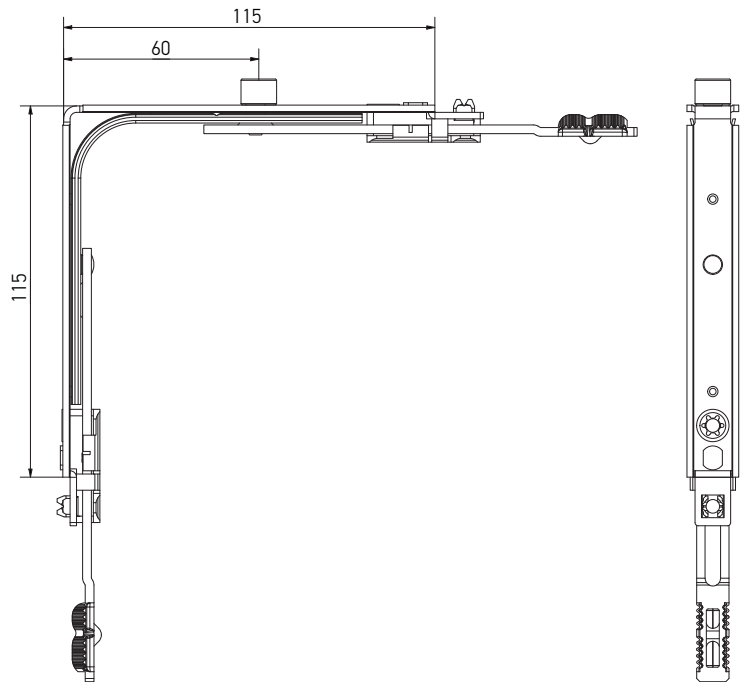

Corner transmission, 2 ML 115×115

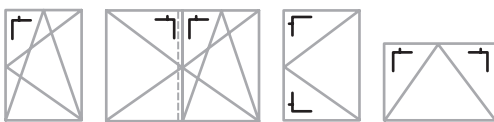
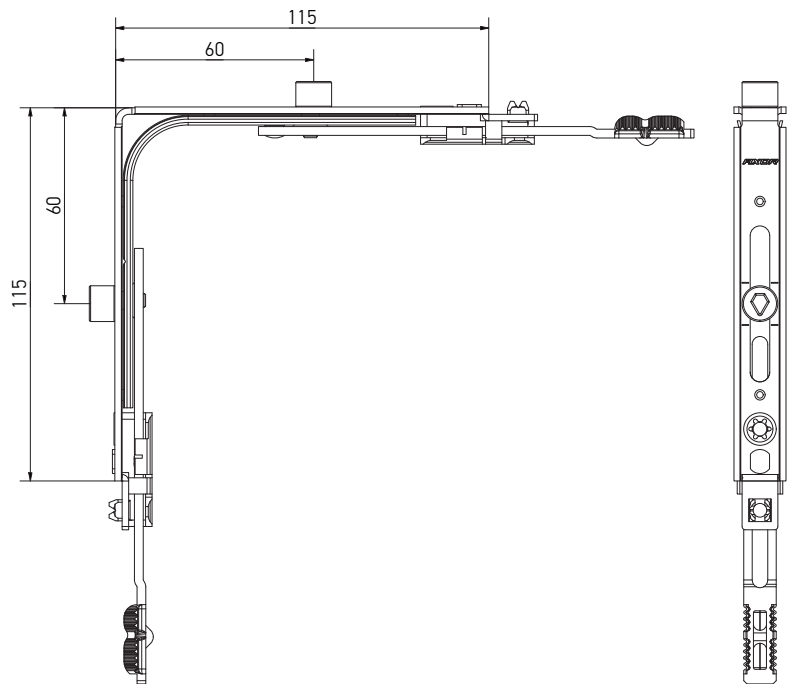

Description	Application range						Part No.
	SRW (mm)	SRH (mm)					
Corner transmission, 1 ML, 115×115	400-1280	450-2390	1	—	4	50	K2021-00-N03
Corner transmission, 2 ML, 115×115	400-1280	450-2390	2	—	4	50	K2022-00-N03
Corner transmission, without locking pin, 115×115	400-1280	450-2390	—	—	4	50	K2036-00-N03



**Corner transmissions**

Corner transmissions  
Middle locks

Corner transmission, 1 MR, 115×115

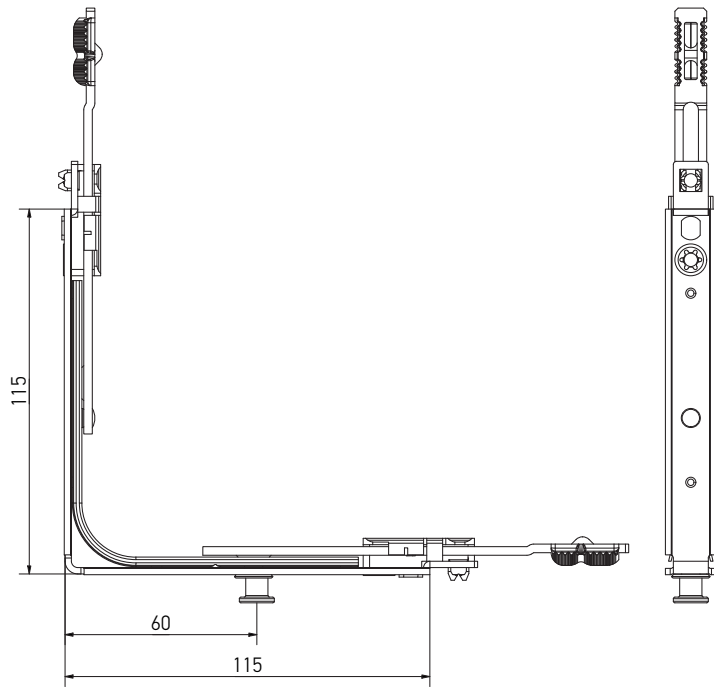

Corner transmission, 2 MR, 115×115

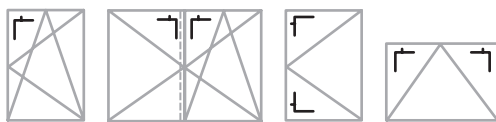
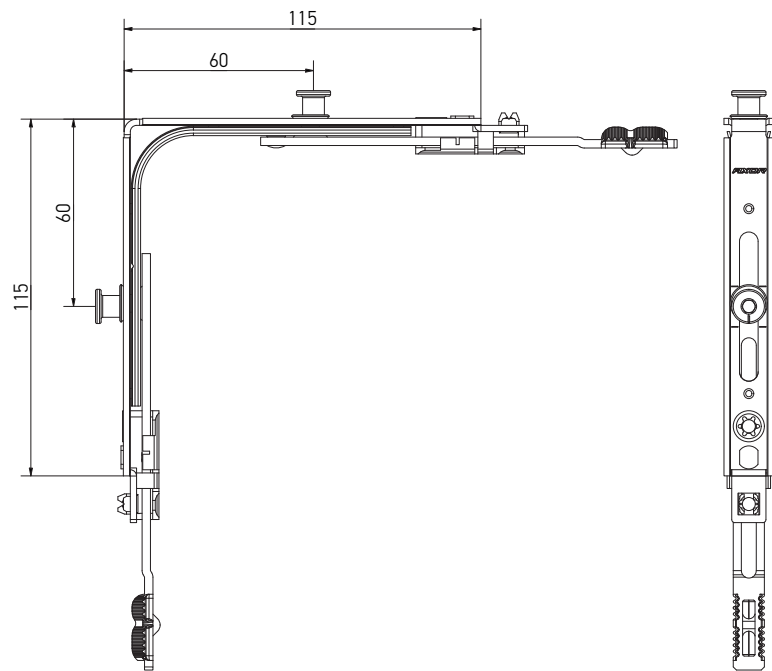

Description	Application range						Part No.
	SRW (mm)	SRH (mm)					
Corner transmission, 1 MR, 115×115	400-1280	450-2390	—	1	4	50	K2025-00-N03
Corner transmission, 2 MR, 115×115	400-1280	450-2390	—	2	4	50	K2032-00-N03
Corner transmission, 1 ML, 1 MR, 115×115	400-1280	450-2390	1	1	4	50	K2033-00-N03

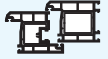

**Corner transmissions**

Corner transmissions  
Middle locks

Corner transmission, bottom, 1 MR, 115×115

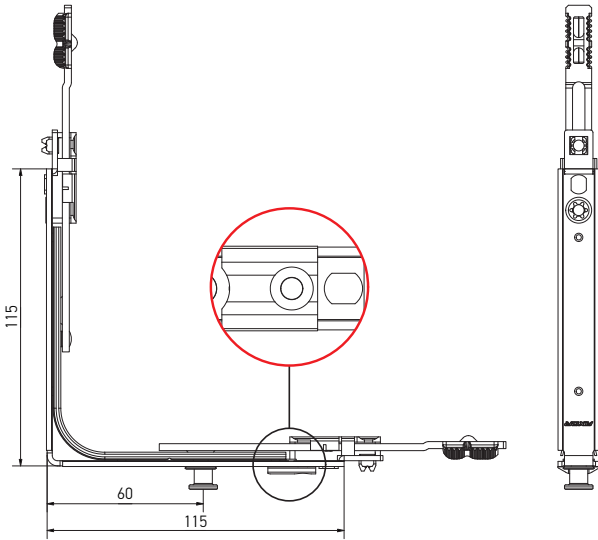

Corner transmission, bottom, 2 MR, 115×115

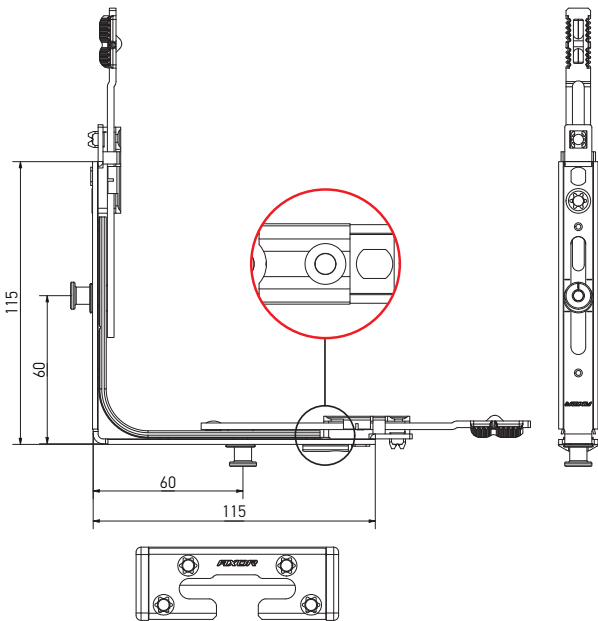

Description	Application range						Part No.
	SRW (mm)	SRH (mm)					
Corner transmission, bottom, 1 MR, 115×115	400-1280	450-2390	—	1	4	50	K2028-00-N03
Corner transmission, bottom, 2 MR, 115×115	400-1280	450-2390	—	2	4	50	K2029-00-N03



**Narrow corner transmission**

Corner transmissions  
Middle locks

Narrow corner transmission, 1 ML, 15×115

Narrow corner transmission, 1 MR, 115×15

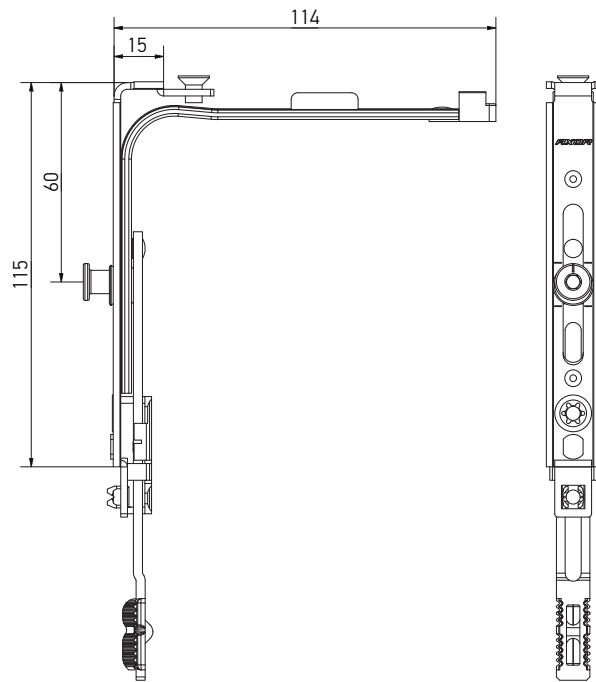
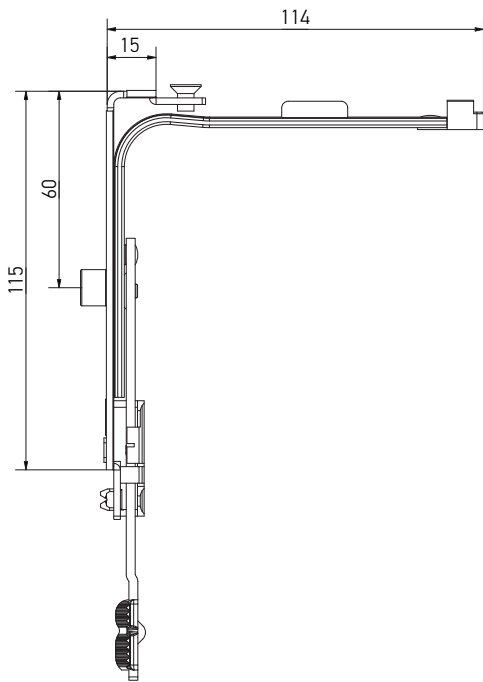

- not intended for double-sash windows

In order to use the narrow corner transmission according to scheme B the distance from the bottom of the fitting groove to the handle axis should be 225 mm, i.e. a hole for handle on gear K1001-02-N03 is displaced from the center of the sash in application range of the sash's height 370-450 mm.

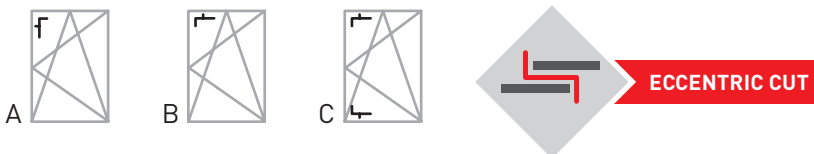

Description	Side opening	Application range						Part No.
		SRW (mm)	SRH (mm)					
Narrow corner transmission, 1 ML, 115×15	A	300-400	450-2390	1	—	3	50	K2023-00-N03
Narrow corner transmission, 1 ML, 115×15	B	400-600	370-450	1	—	3	50	K2023-00-N03
Narrow corner transmission, 1 MR, 115×15	A	300-400	450-2390	—	1	3	50	K2026-00-N03
Narrow corner transmission, 1 MR, 115×15	B	400-600	370-450	—	1	3	50	K2026-00-N03
Narrow corner transmission, 1 MR, 115×15	C	400-600	300-350	—	1	3	50	K2026-00-N03
Narrow corner transmission, without locking pin, 115×15	A	300-400	450-2390	—	—	3	50	K2037-00-N03
Narrow corner transmission, without locking pin, 115×15	B	400-600	370-450	—	—	3	50	K2037-00-N03

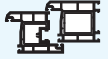

**Corner transmission, integrated slit**

Corner transmissions  
Middle locks

Corner transmission, integrated slit, 1 ML, 115×115

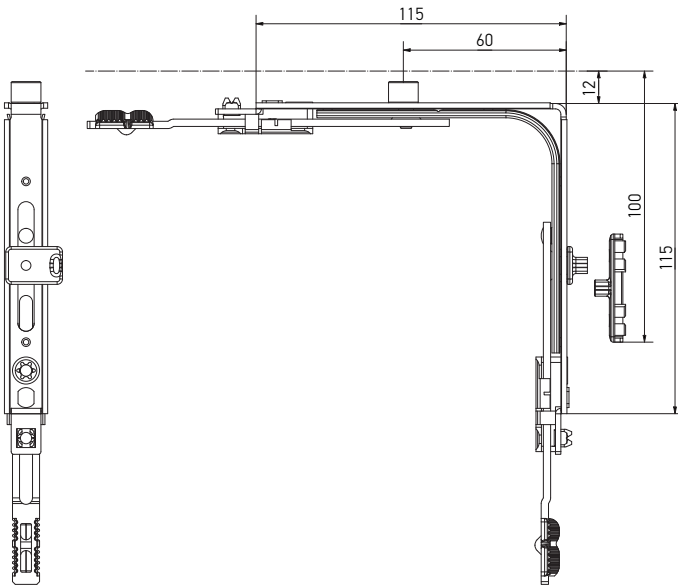

Corner transmission, integrated slit, 1 MR, 115×115

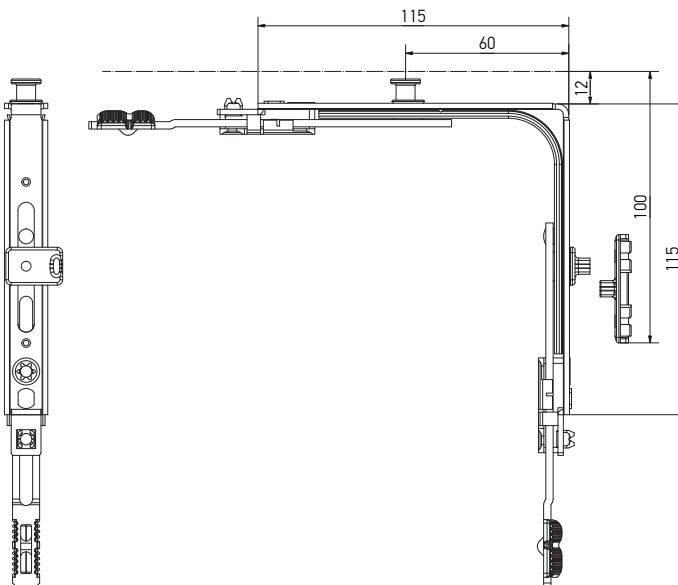

Description	Application range						Part No.
	SRW (mm)	SRH (mm)					
Corner transmission, integrated slit, 1 ML, left, 115×115	400-1280	450-2390	1	—	4	50	K2024-00-L03
Corner transmission, integrated slit, 1 ML, right, 115×115	400-1280	450-2390	1	—	4	50	K2024-00-R03
Corner transmission, integrated slit, 1 MR, 115×115, left	400-1280	450-2390	—	1	4	50	K2034-00-L03
Corner transmission, integrated slit, 1 MR, 115×115, right	400-1280	450-2390	—	1	4	50	K2034-00-R03

Locking plate for integrated slit (frame part)

look at the section "Profile-dependent elements"



**Corner transmission, double sash**

Corner transmissions  
Middle locks

Corner transmission, double sash, 1 ML, 115×115, top

Corner transmission, double sash, 1 MR, 115×115, top

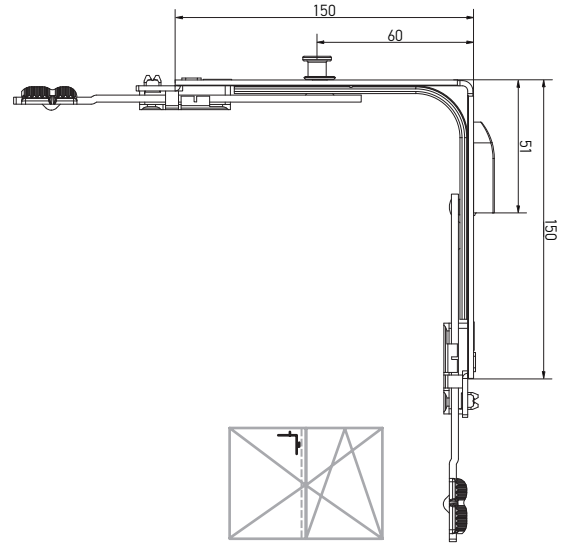
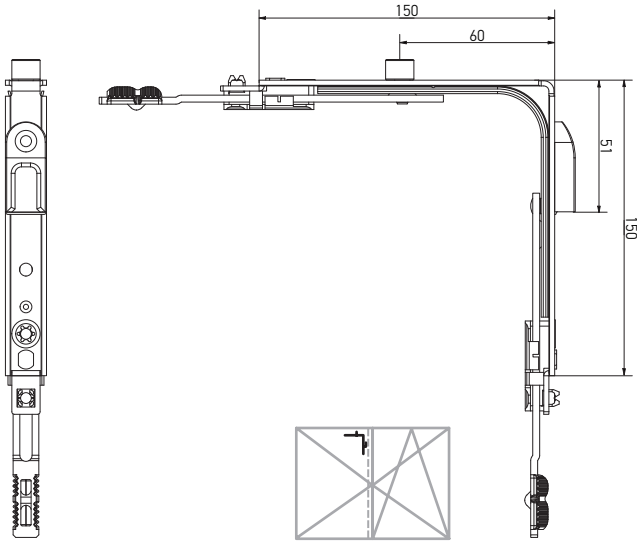

Corner transmission, double sash, 1 ML, 115×115, bottom

Corner transmission, double sash, 1 MR, 115×115, bottom

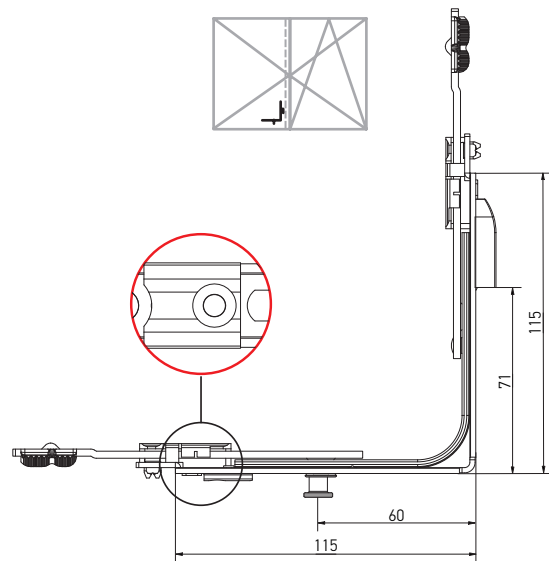
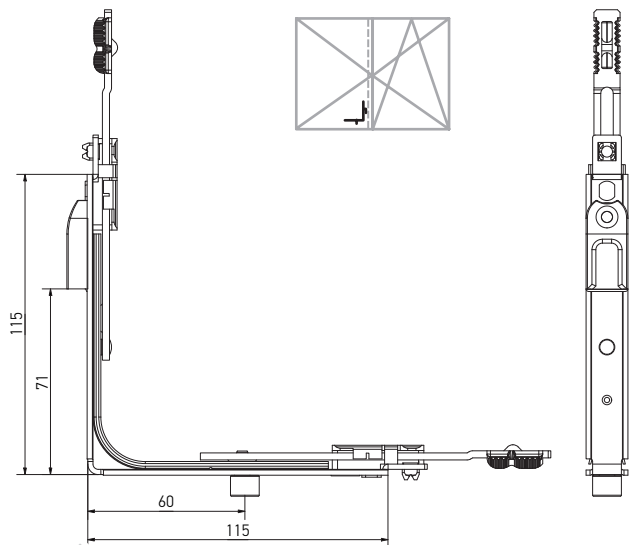

Description	Application range							Part No.
	SRW (mm)	SRH (mm)						
Corner transmission, double sash, 1 ML, 115×115, top	400-1280	450-2390	1	—	1	4	50	K2027-01-N03
Corner transmission, double sash, 1 MR, 115×115, top	400-1280	450-2390	—	1	1	4	50	K2031-00-N03
Corner transmission, double sash, 1 ML, 115×115, bottom	400-1280	450-2390	1	—	1	4	50	K2027-02-N03
Corner transmission, double sash, 1 MR, 115×115, bottom	400-1280	450-2390	—	1	1	4	50	K2030-00-N03



Corner transmission for aluminium doorstep, 1 MR, 115×115

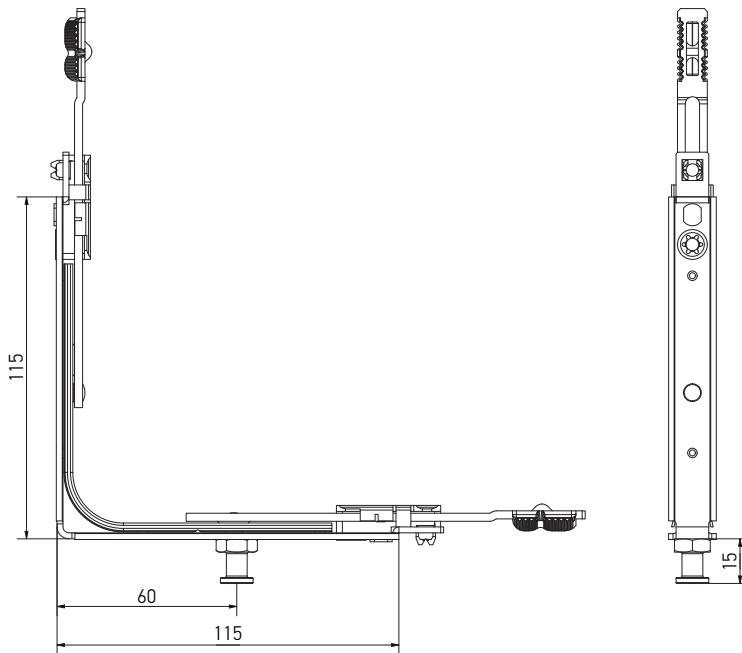

**ECCENTRIC CUT**

Description	Application range					Part No.
	SRW (mm)	SRH (mm)				
Corner transmission for aluminium doorstep, 1 MR, 115×115	400-1280	450-2390	1	4	50	K2035-00-N03





### Middle lock

Corner transmissions  
Middle locks

#### Middle lock

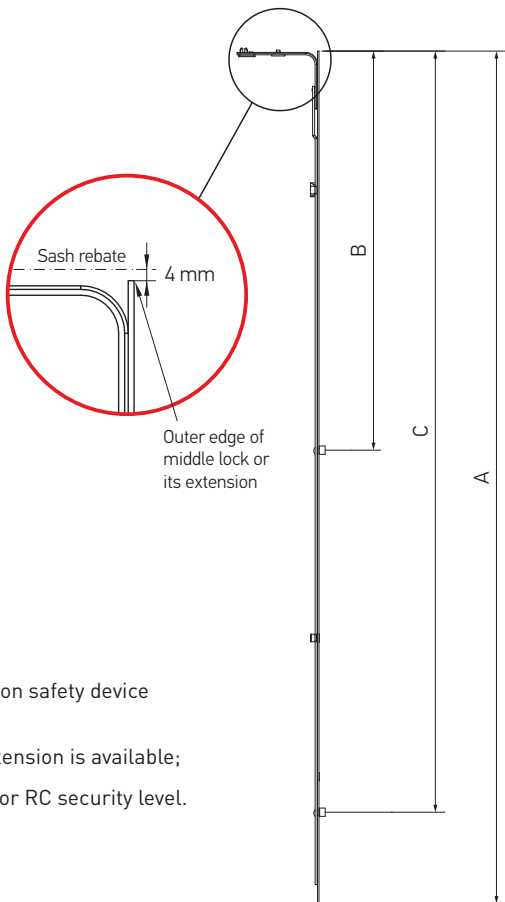

- wrong operation safety device is necessary;
- addition of extension is available;
- not intended for RC security level.

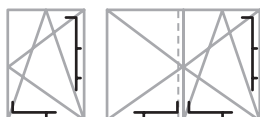

#### Middle lock extension, 1 ML, 480 mm

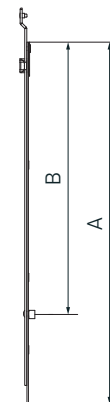

#### Middle lock extension, 1 ML, 680 mm

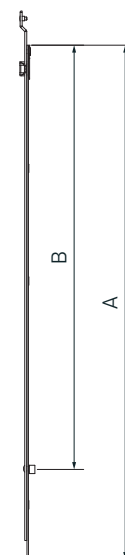

- for additional locking point;
- for height > 1710 mm.

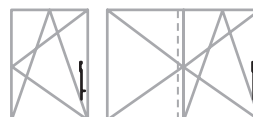

Description	SRH (mm)	SRW (mm)	Dimensions			Cylinder	Screw	Box	Part No.
			A	B*	C*				
Middle lock L=400, 1 ML	600-1000	600-1000	400	280	—	1	3	20	K4001-04-N03
Middle lock L=650, 1 ML	850-1250	850-1250	650	530	—	1	5	20	K4001-06-N03
Middle lock L=720, 1 ML	920-1320	920-1320	720	600	—	1	5	20	K4001-07-N03
Middle lock L=820, 1 ML	1251-1430	1251-1430	820	700	—	1	5	20	K4001-08-N03
Middle lock L=1130, 2 ML	1251-1730	—	1130	530	1010	2	8	20	K4001-11-N03

Description	SRH (mm)	SRW (mm)	Dimensions			Cylinder	Screw	Box	Part No.
			A	B	C				
Middle lock extension, 1 ML, 480 mm	1710-2210	1280-1520	480	360	—	1	4	20	K4005-05-N03
Middle lock extension, 1 ML, 680 mm	2211-2390	—	680	560	—	1	5	20	K4005-07-N03

\*Dimensions B and C are distances from the outer edge of middle lock or its extension to the locking pin axis



**Middle lock**

Corner transmissions  
Middle locks

**Middle lock**

**Middle lock extension,  
1 MR, 480 mm**

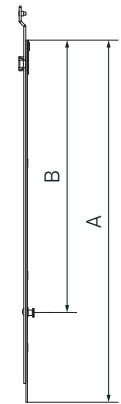
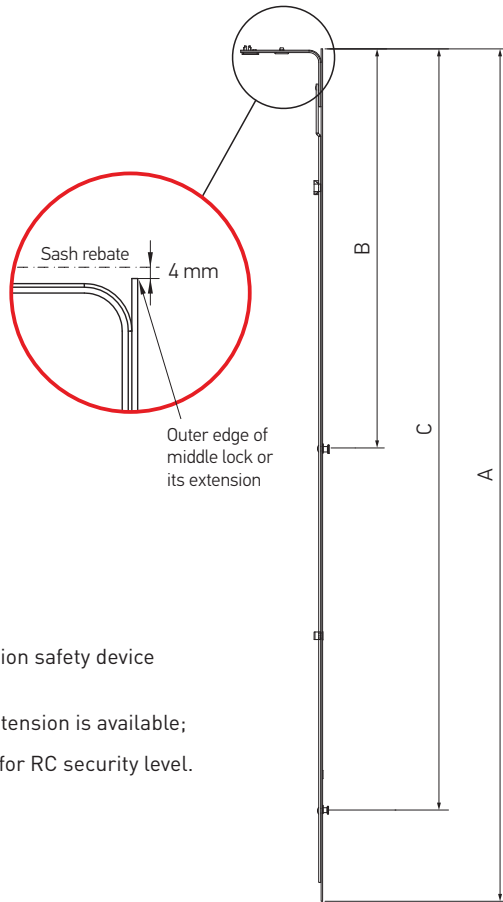

**Middle lock extension,  
1 MR, 680 mm**

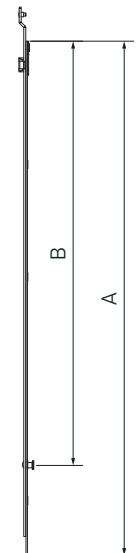

- wrong operation safety device is necessary;
- addition of extension is available;
- not intended for RC security level.

- for additional locking point;
- for height > 1710 mm.

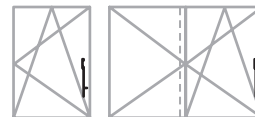
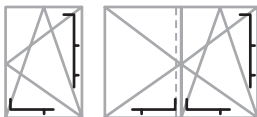

Description	SRH (mm)	SRW (mm)	Dimensions						Part No.
			A	B*	C*				
Middle lock L=400, 1 MR	600-1000	600-1000	400	280	—	1	3	20	K4017-04-N03
Middle lock L=650, 1 MR	850-1250	850-1250	650	530	—	1	5	20	K4017-06-N03
Middle lock L=820, 1 MR	1251-1430	1251-1430	820	700	—	1	5	20	K4017-08-N03
Middle lock L=1130, 2 MR	1251-1730	—	1130	530	1010	2	8	20	K4017-11-N03
Description	SRH (mm)	SRW (mm)	Dimensions						Part No.
			A	B	C				
Middle lock extension, 1 MR, 480 mm	1710-2210	1280-1520	480	360	—	1	4	20	K4025-05-N03
Middle lock extension, 1 MR, 680 mm	2211-2390	—	680	560	—	1	5	20	K4025-07-N03

\*Dimensions B and C are distances from the outer edge of middle lock or its extension to the locking pin axis



### Middle lock, 2ML

Corner transmissions  
Middle locks

Middle lock, 2ML

Middle lock extension, 1 ML, 480 mm

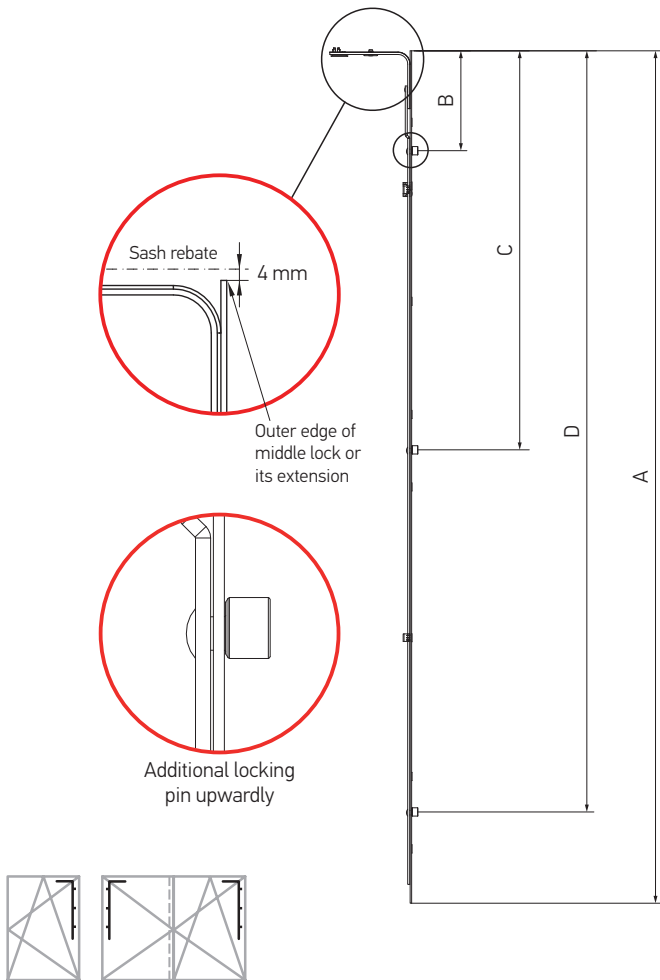

Middle lock extension, 1 ML, 680 mm

- for additional locking point;  
- for height > 1710 mm.

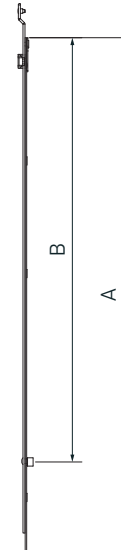
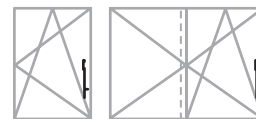

Description	SRH (mm)	SRW (mm)	Dimensions							Part No.
			A	B*	C*	D*				
Middle lock, L=400, 2 ML	600-1000	600-1000	400	132	280	—	2	3	20	K4004-04-N03
Middle lock, L=650, 2 ML	850-1250	850-1250	650	132	530	—	2	5	20	K4004-06-N03
Middle lock, L=720, 2 ML	920-1320	920-1320	720	132	600	—	2	5	20	K4004-07-N03
Middle lock, L=820, 2 ML	1251-1430	1251-1430	820	132	700	—	2	5	20	K4004-08-N03
Middle lock, L=1130, 3 ML	1251-1730	—	1130	132	530	1010	3	8	20	K4004-11-N03

Description	SRH (mm)	SRW (mm)	Dimensions						Part No.
			A	B	C				
Middle lock extension, 1 ML, 480 mm	1710-2210	1280-1520	480	360	—	1	4	20	K4005-05-N03
Middle lock extension, 1 ML, 680 mm	2211-2390	—	680	560	—	1	5	20	K4005-07-N03

\* Dimensions B, C and D are distances from the outer edge of middle lock or its extension to the locking pin axis



**Middle lock, 2 MR**

Corner transmissions  
Middle locks

Middle lock, 2 MR

Middle lock extension, 1 MR, 480 mm

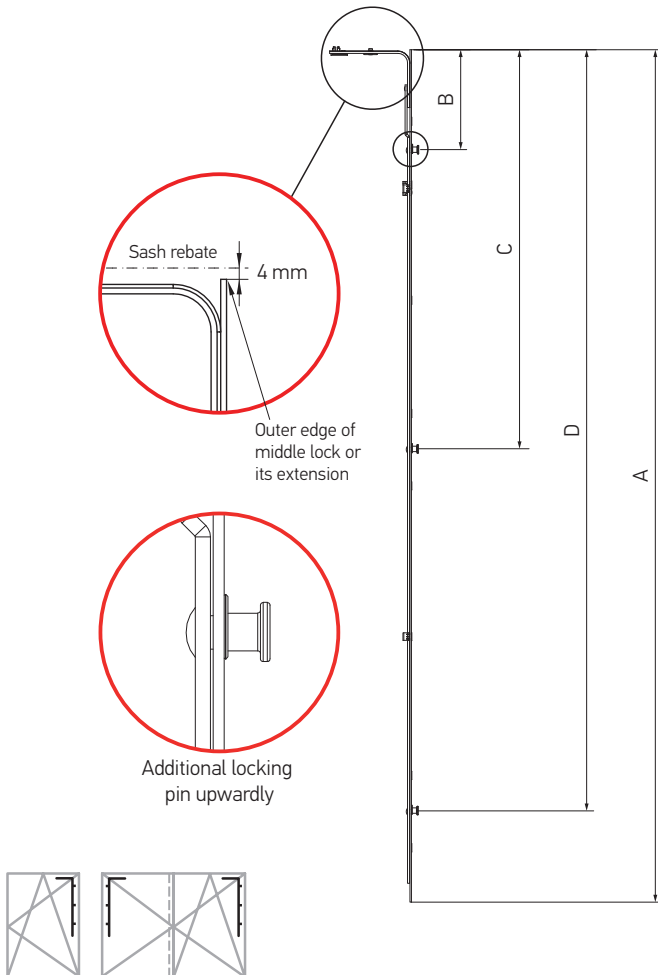

Middle lock extension, 1 MR, 680 mm

- for additional locking point;  
- for height > 1710 mm.

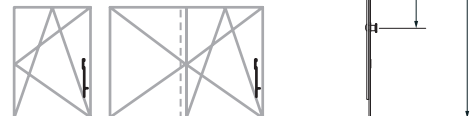

Description	SRH (mm)	SRW (mm)	Dimensions							Part No.
			A	B*	C*	D*				
Middle lock L=400, 2 MR	600-1000	600-1000	400	132	280	—	2	3	20	K4024-04-N03
Middle lock L=650, 2 MR	850-1250	850-1250	650	132	530	—	2	5	20	K4024-06-N03
Middle lock L=820, 2 MR	1251-1430	1251-1430	820	132	700	—	2	5	20	K4024-08-N03
Middle lock L=1130, 3 MR	1251-1730	—	1130	132	530	1010	3	8	20	K4024-11-N03
Description	SRH (mm)	SRW (mm)	Dimensions						Part No.	
			A	B	C					
Middle lock extension, 1 MR, 480 mm	1710-2210	1280-1520	480	360	—	1	4	20	K4025-05-N03	
Middle lock extension, 1 MR, 680 mm	2211-2390	—	680	560	—	1	5	20	K4025-07-N03	

\* Dimensions B, C and D are distances from the outer edge of middle lock or its extension to the locking pin axis



### Middle lock with additional mushroom pin

Corner transmissions  
Middle locks

Middle lock ML with additional mushroom pin MR

Middle lock extension, 1 ML, 480 mm

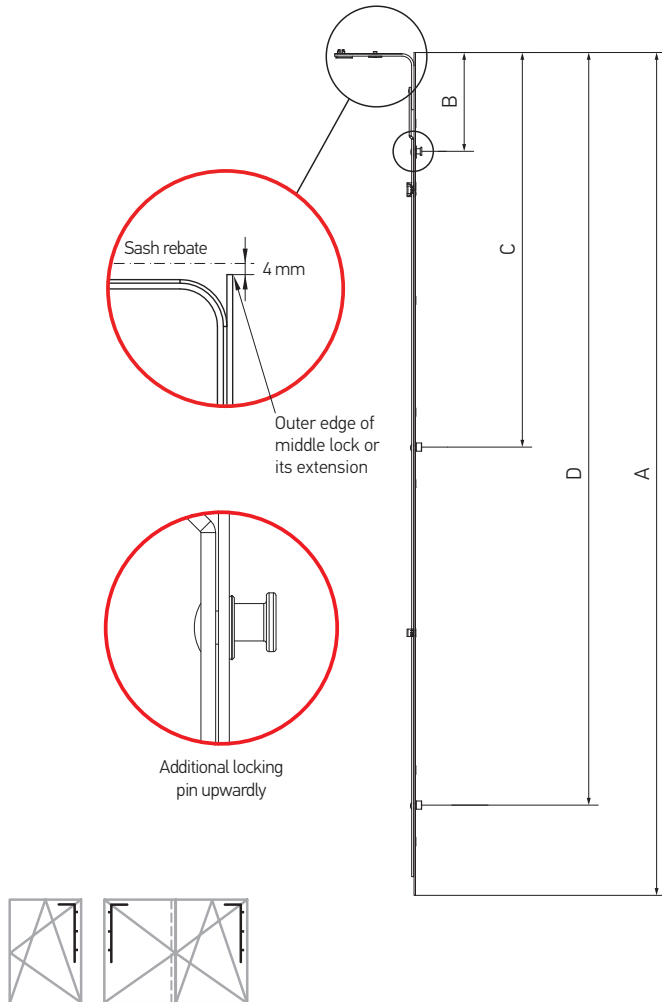

Middle lock extension, 1 ML, 680 mm

- for additional locking point;  
- for height > 1710 mm.

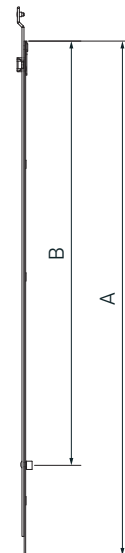

Description	SRH (mm)	SRW (mm)	Dimensions								Part No.
			A	B*	C*	D*					
Middle lock L=400, 1 MR + 1 ML, 600-1000	600-1000	600-1000	400	132	280	—	1	1	3	20	K4008-04-N03
Middle lock L=650, 1 MR + 1 ML, 850-1250	850-1250	850-1250	650	132	530	—	1	1	5	20	K4008-06-N03
Middle lock L=820, 1 MR + 1 ML, 1250-1430	1251-1430	1251-1430	820	132	700	—	1	1	5	20	K4008-08-N03
Middle lock L=1130, 1 MR + 2 ML, 1250-1730	1251-1730	—	1130	132	530	1010	2	1	8	20	K4008-11-N03
Description	SRH (mm)	SRW (mm)	Dimensions							Part No.	
			A	B	C						
Middle lock extension, 1 ML, 480 mm	1710-2210	1280-1520	480	360	—	1	0	4	20	K4005-05-N03	
Middle lock extension, 1 ML, 680 mm	2211-2390	—	680	560	—	1	0	5	20	K4005-07-N03	

\* Dimensions B, C and D are distances from the outer edge of middle lock or its extension to the locking pin axis

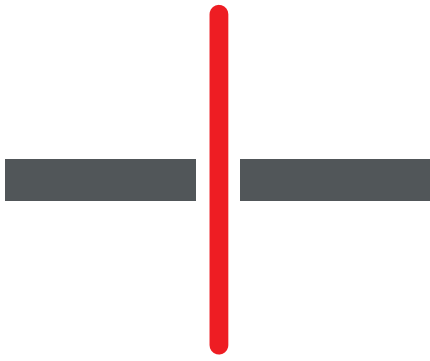

# Extension locks

FOR STRAIGHT CUT

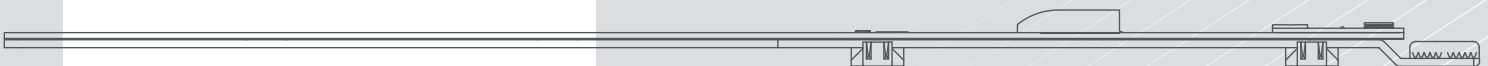



**Extension locks**

Corner transmissions  
Middle locks

Extension lock 240 mm, 1 ML

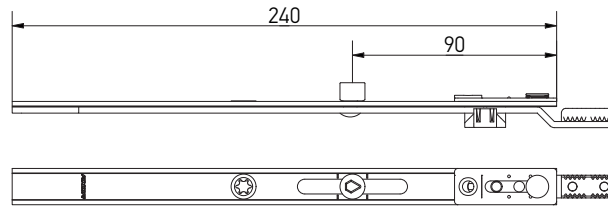

Extension lock 480 mm, 1 ML

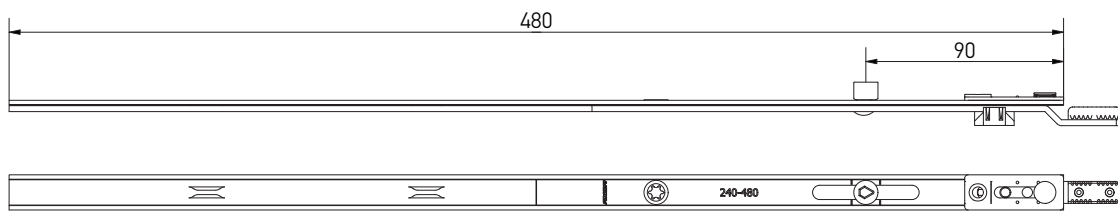

Extension lock 240 mm, 1 MR

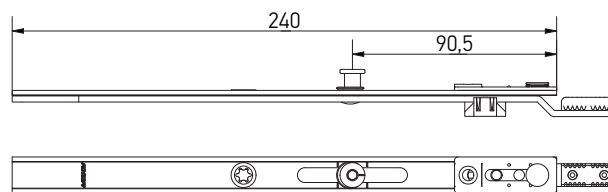

Extension lock 480 mm, 1 MR

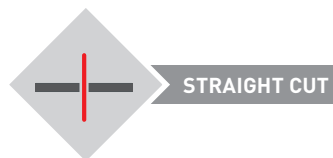
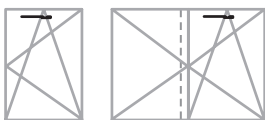
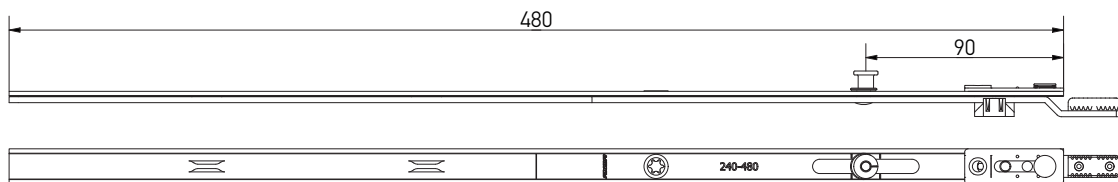

Description	Dimension					Part No.
Extension lock 240 mm, 1 ML	240	1	—	2	25	K4003-02-N03
Extension lock 480 mm, 1 ML	480	1	—	2	25	K4003-05-N03
Extension lock 240 mm, 1 MR	240	—	1	2	25	K4023-02-N03
Extension lock 480 mm, 1 MR	480	—	1	2	25	K4023-05-N03



**Extension locks**

Corner transmissions  
Middle locks

Extension lock for corner transmission 480 mm, 1 ML

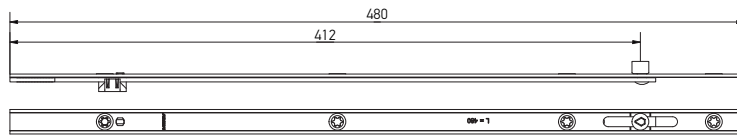

Extension lock for corner transmission 680 mm, 1 ML

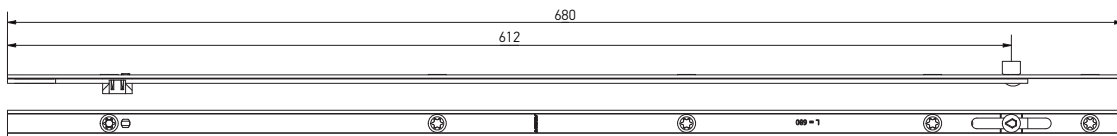

Extension lock for corner transmission 880 mm, 2 ML

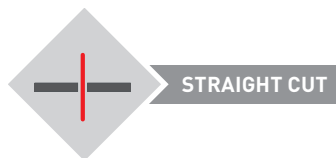
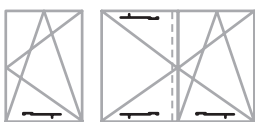
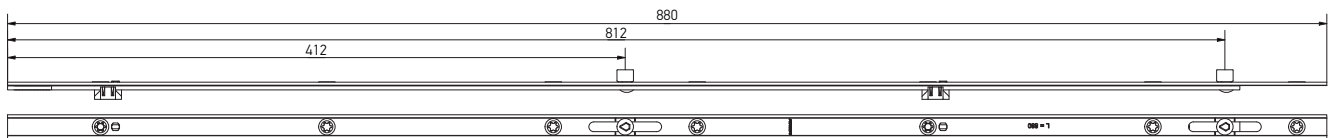

Description	Dimension				Part No.
Extension lock for corner transmission 480 mm, 1 ML	480	1	4	20	K4010-00-N03
Extension lock for corner transmission 680 mm, 1 ML	680	1	4	20	K4010-07-N03
Extension lock for corner transmission 880 mm, 2 ML	880	1	4	20	K4010-09-N03





**Extension locks**

Corner transmissions  
Middle locks

Extension lock for corner transmission 480 mm, 1 MR

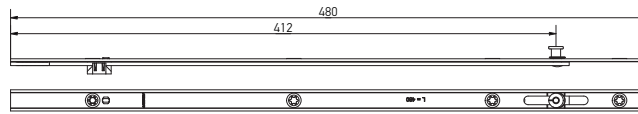

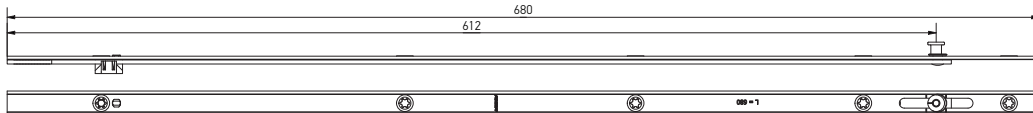

Extension lock for corner transmission 680 mm, 1 MR

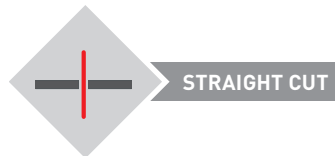
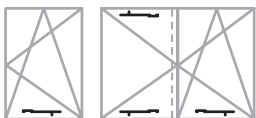
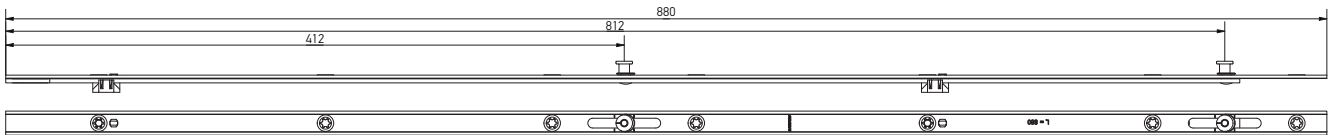

Extension lock for corner transmission 880 mm, 2 MR



Description	Dimension				Part No.
Extension lock for corner transmission 480 mm, 1 MR	480	1	4	20	K4030-00-N03
Extension lock for corner transmission 680 mm, 1 MR	680	1	4	20	K4030-07-N03
Extension lock for corner transmission 880 mm, 2 MR	880	2	4	20	K4030-09-N03



**Extension locks**

Corner transmissions  
Middle locks

Extension lock, double sash 240 mm

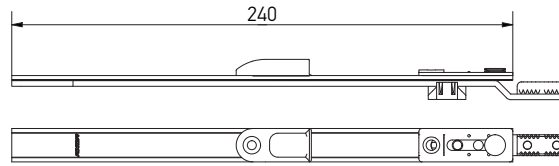

Extension lock, double sash 480 mm

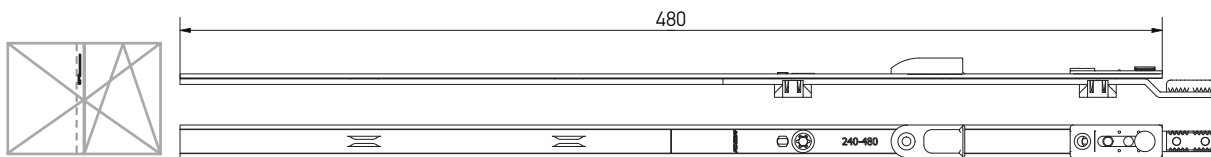

Extension lock 480 mm with possibility to cut, 1 MR

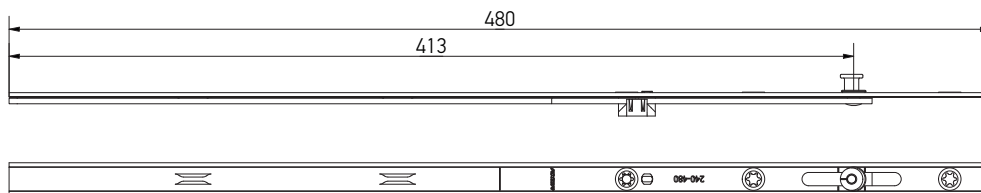

Extension lock 720 mm with possibility to cut, 1 MR

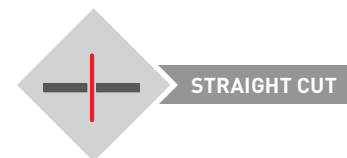
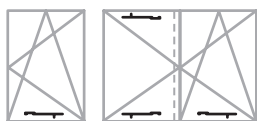
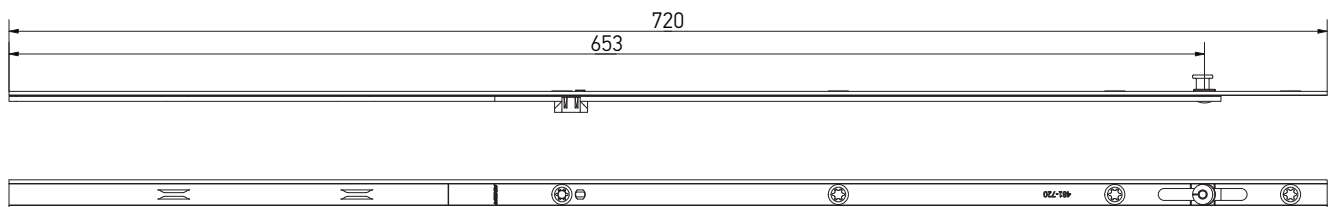

Description	Dimension				Part No.
Extension lock, double sash 240 mm	240	—	2	25	K4015-02-N03
Extension lock, double sash 480 mm	480	—	2	25	K4015-05-N03
Extension lock 480 mm with possibility to cut, 1 MR	480	1	3	20	K4036-05-N03
Extension lock 720 mm with possibility to cut, 1 MR	720	1	4	20	K4036-07-N03



**Extension locks**

Corner transmissions  
Middle locks

Extension lock for aluminium doorstep

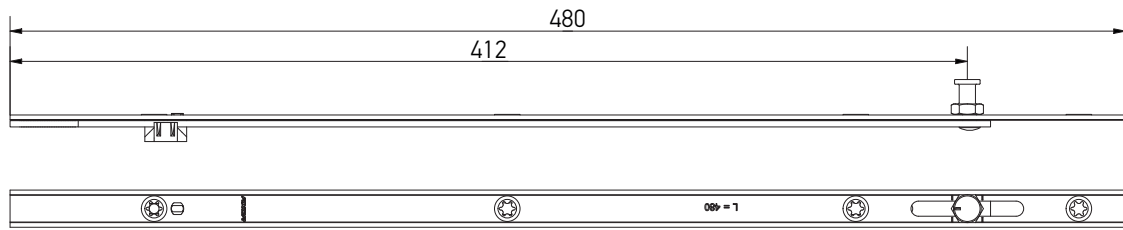

Extension lock 240 mm, without locking pin

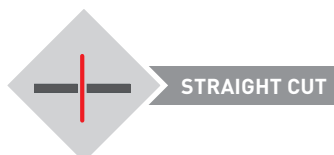
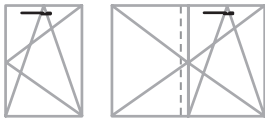
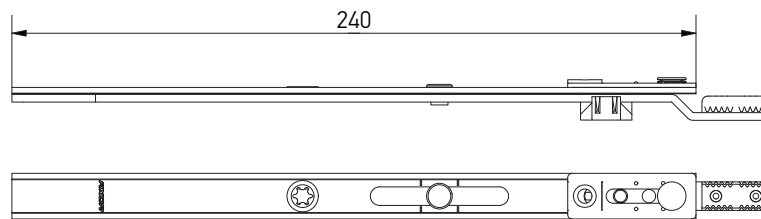

Description	Dimension					Part No.
Extension lock 480 mm, for aluminium doorstep, 1 MR	480	—	1	4	20	K4039-05-N03
Extension lock 240 mm, without locking pin	240	—	—	2	20	K4038-02-N03



**Extension lock with sash lifter, ML**

Corner transmissions  
Middle locks

Extension lock L=480 mm, 1 ML, with sash lifter

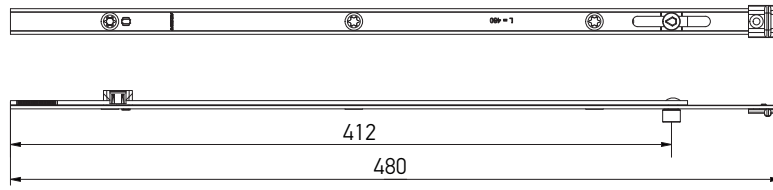

Extension lock L=680 mm, 1 ML, with sash lifter

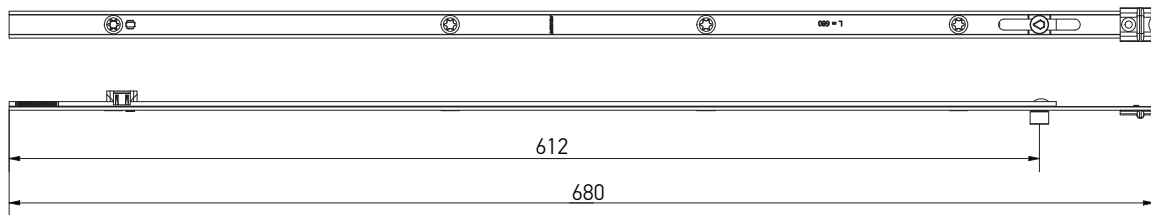

Extension lock L=880 mm, 2 ML, with sash lifter

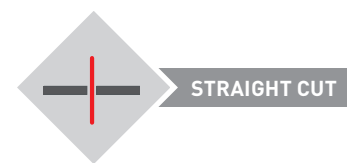
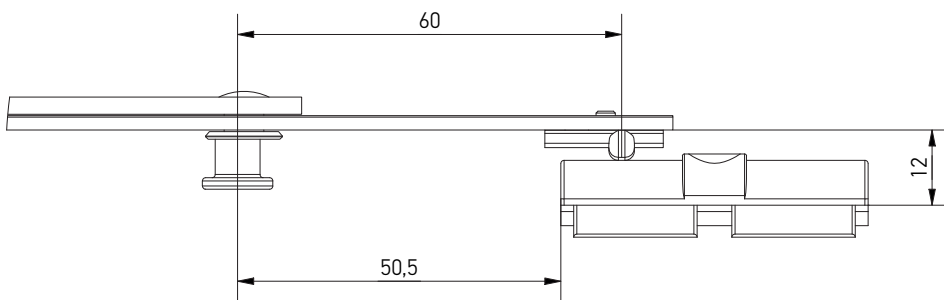
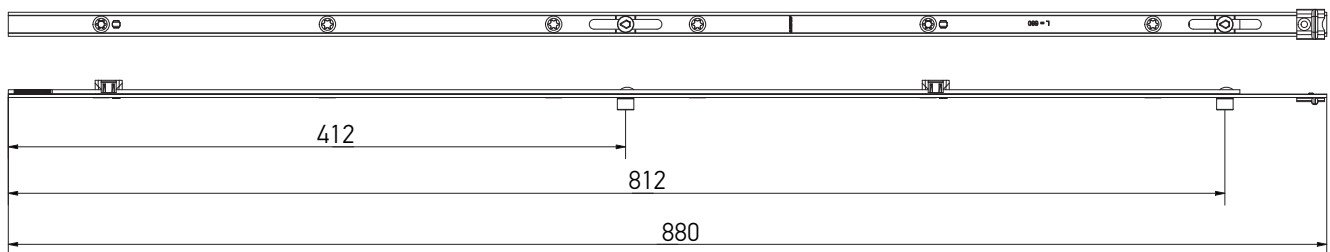

The extension locks K4062-XX-N03, K4063-XX-N03, K4066-XX-N03, K4067-XX-N03 use together with the suitable frame part A7237-XX-N03.

The suitable frame part (A7237-XX-N03) can be found on p. 207.

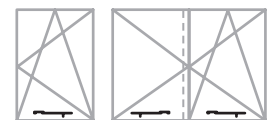

Description	Dimension				Part No.
Extension lock L=480 mm, 1 ML, with sash lifter	480	1	4	20	K4062-05-N03
Extension lock L=680 mm, 1 ML, with sash lifter	680	1	5	20	K4062-07-N03
Extension lock L=880 mm, 2 ML, with sash lifter	880	2	7	20	K4062-09-N03
Frame part of sash lifter	Look at the section "Profile-dependent elements"				



**Extension lock with sash lifter, MR**

Corner transmissions  
Middle locks

Extension lock L=480 mm, 1 MR, with sash lifter

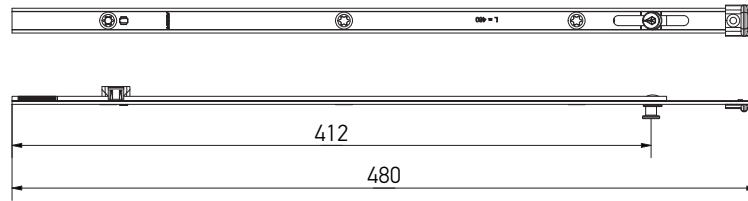

Extension lock L=680 mm, 1 MR, with sash lifter

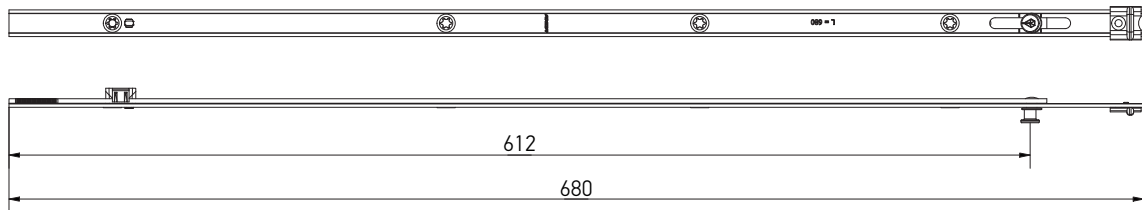

Extension lock L=880 mm, 2 MR, with sash lifter

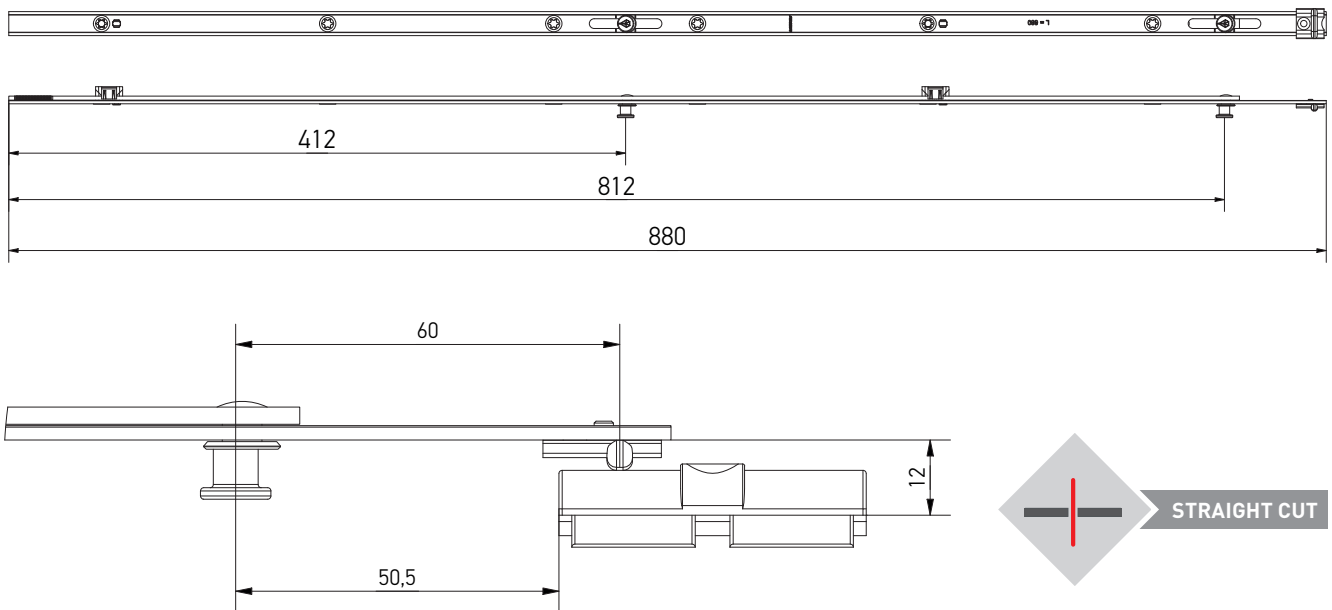

The extension locks K4062-XX-N03, K4063-XX-N03, K4066-XX-N03, K4067-XX-N03 use together with the suitable frame part A7237-XX-N03.

The suitable frame part (A7237-XX-N03) can be found on p. 207.

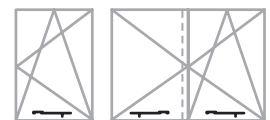

Description	Dimension				Part No.
Extension lock L=480 mm, 1 MR, with sash lifter	480	1	4	20	K4063-05-N03
Extension lock L=680 mm, 1 MR, with sash lifter	680	1	5	20	K4063-07-N03
Extension lock L=880 mm, 2 MR, with sash lifter	880	2	7	20	K4063-09-N03
Frame part of sash lifter	Look at the section "Profile-dependent elements"				

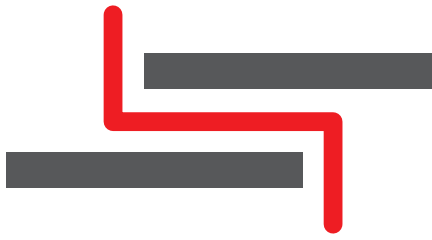

# Extension locks

FOR ECCENTRIC CUT

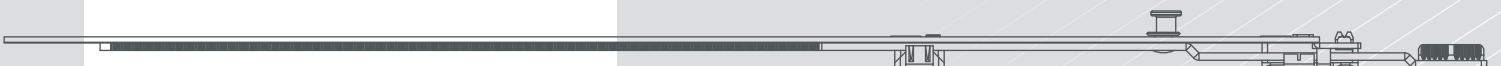



**Extension locks**

Corner transmissions  
Middle locks

Extension lock 240 mm, 1 ML

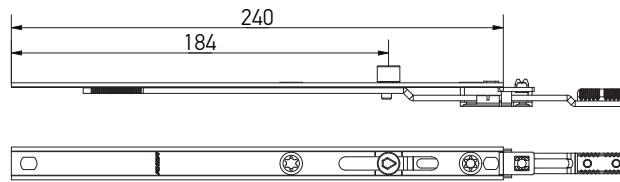

Extension lock 480 mm, 1 ML

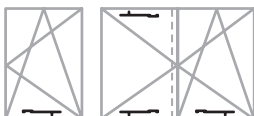
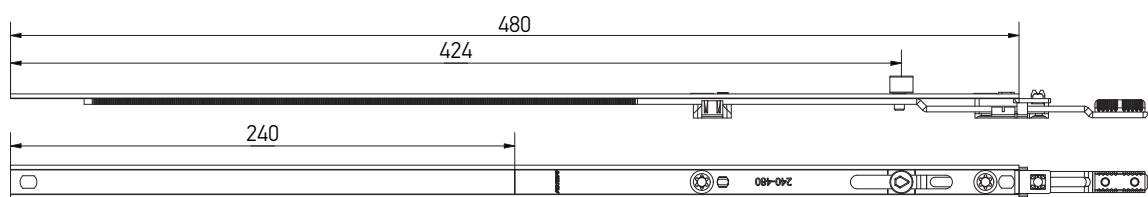

Description	Dimension				Part No.
Extension lock 240 mm, 1 ML	240	1	2	25	K4056-02-N03
Extension lock 480 mm, 1 ML	480	1	2	25	K4056-05-N03



**Extension locks**

Corner transmissions  
Middle locks

Extension lock for corner transmission 480 mm, 1 ML

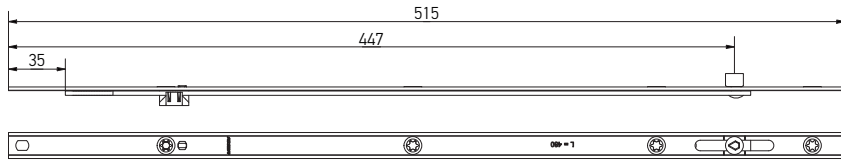

Extension lock for corner transmission 680 mm, 1 ML

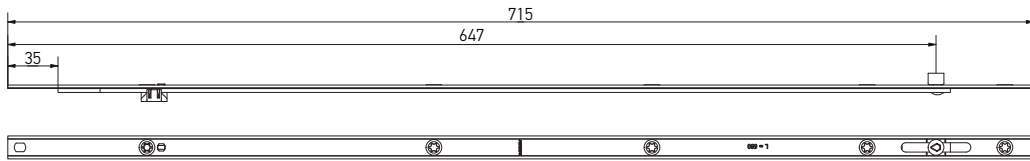

Extension lock for corner transmission 880 mm, 2 ML

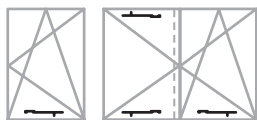
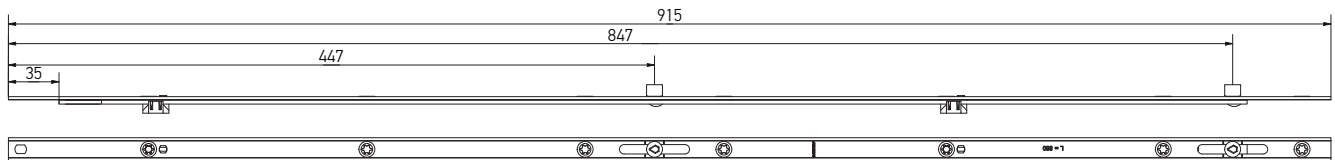

Description	Dimension				Part No.
Extension lock for corner transmission 480 mm, 1 ML	515	1	4	20	K4053-05-N03
Extension lock for corner transmission 680 mm, 1 ML	715	1	4	20	K4053-07-N03
Extension lock for corner transmission 880 mm, 2 ML	915	2	4	20	K4053-09-N03





**Extension locks**

Corner transmissions  
Middle locks

Extension lock for corner transmission 480 mm, 1 MR

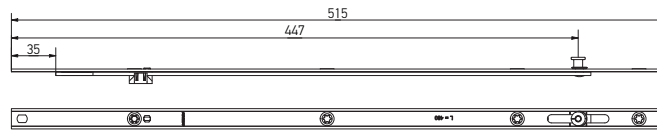

Extension lock for corner transmission 680 mm, 1 MR

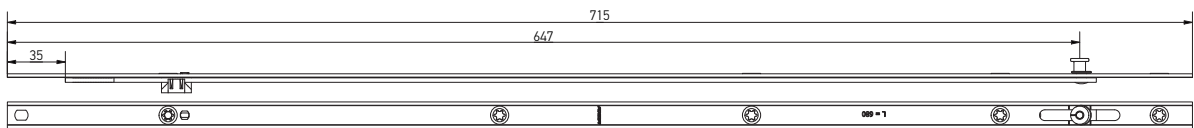

Extension lock for corner transmission 880 mm, 2 MR

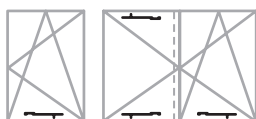
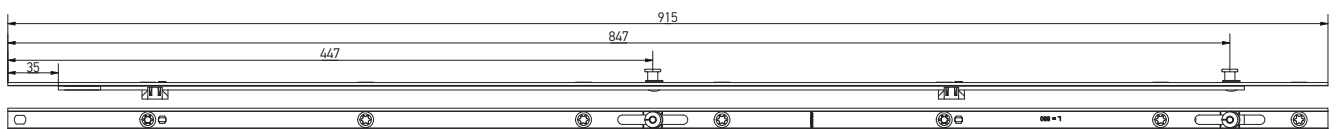

Description	Dimension				Part No.
Extension lock for corner transmission 480 mm, 1 MR	515	1	4	20	K4054-05-N03
Extension lock for corner transmission 680 mm, 1 MR	715	1	4	20	K4054-07-N03
Extension lock for corner transmission 880 mm, 2 MR	915	2	4	20	K4054-09-N03



**Extension locks**

Corner transmissions  
Middle locks

Extension lock, double sash 240 mm

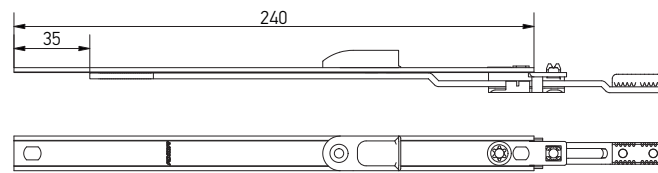

Extension lock, double sash 480 mm

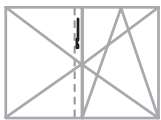
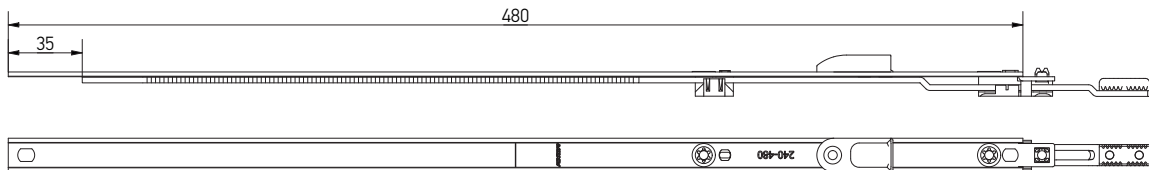



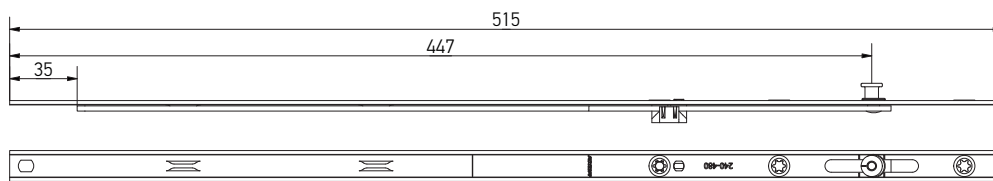

Extension lock with possibility to cut, 1 MR

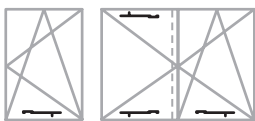
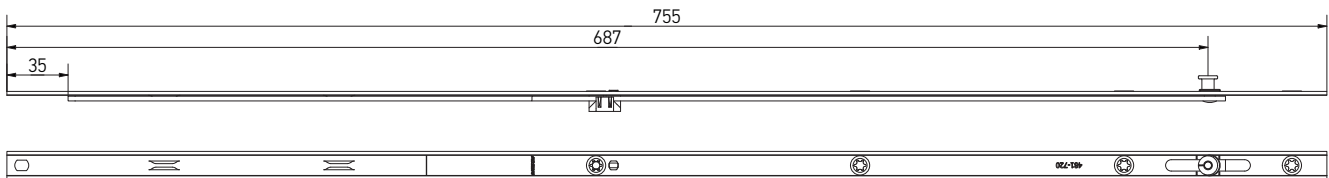

Extension lock with possibility to cut, 1 MR



Description	Dimension					Part No.
Extension lock, double sash 240 mm	240	—	—	1	25	K4055-02-N03
Extension lock, double sash 480 mm	480	—	—	2	25	K4055-05-N03
Extension lock 480 mm with possibility to cut, 1 MR	515	—	1	3	20	K4058-05-N03
Extension lock 720 mm with possibility to cut, 1 MR	755	—	1	4	20	K4058-07-N03



**Extension lock for aluminium doorstep**

Corner transmissions  
Middle locks

Extension lock for aluminium doorstep

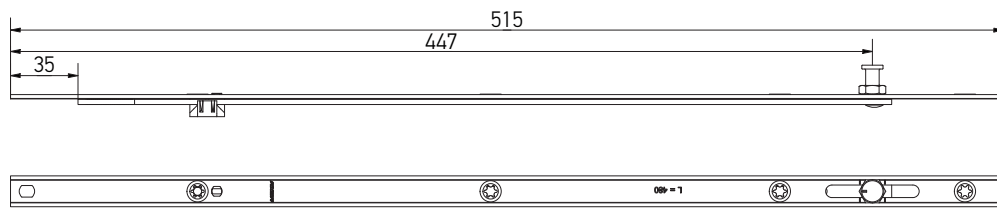

Extension lock, without locking pin



**ECCENTRIC CUT**

Description	Dimension					Part No.
Extension lock 480 mm, for aluminium doorstep, 1 MR	515	—	1	4	20	K4059-05-N03
Extension lock 240 mm, without locking pin	240	—	—	2	25	K4057-02-N03



**Extension locks**

Corner transmissions  
Middle locks

Extension lock 240 mm, 1 MR

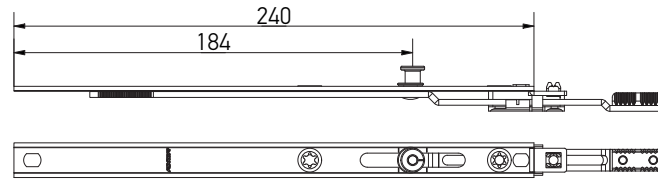

Extension lock 480 mm, 1 MR

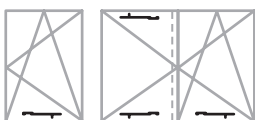
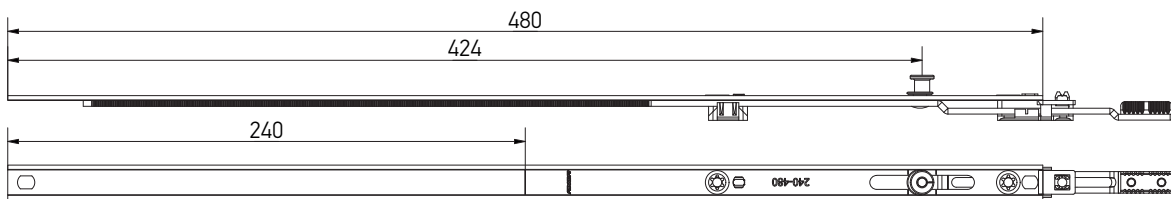

Description	Dimension					Part No.
Extension lock 240 mm, 1 MR	240	—	1	2	25	K4050-02-N03
Extension lock 480 mm, 1 MR	480	—	1	2	25	K4050-05-N03



**Extension lock with sash lifter, ML**

Corner transmissions  
Middle locks

Extension lock L = 480 mm, 1 ML, with sash lifter

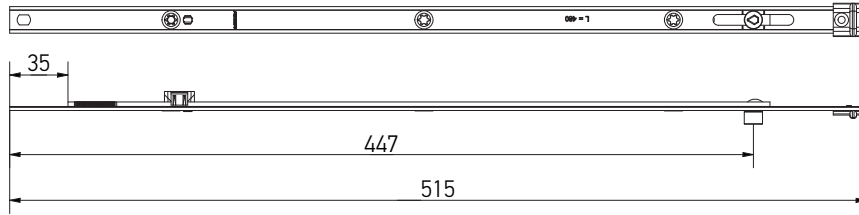

Extension lock L = 680 mm, 1 ML, with sash lifter

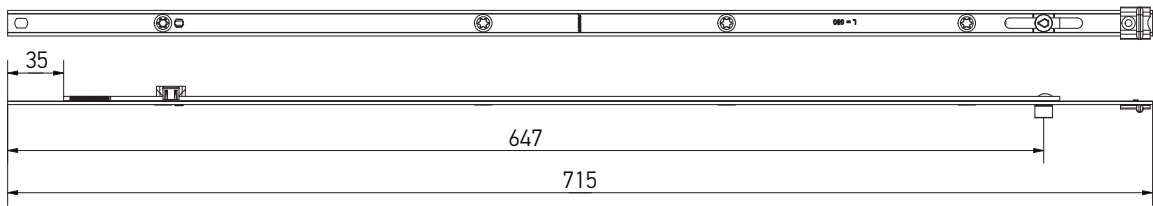

Extension lock L = 880 mm, 2 ML, with sash lifter

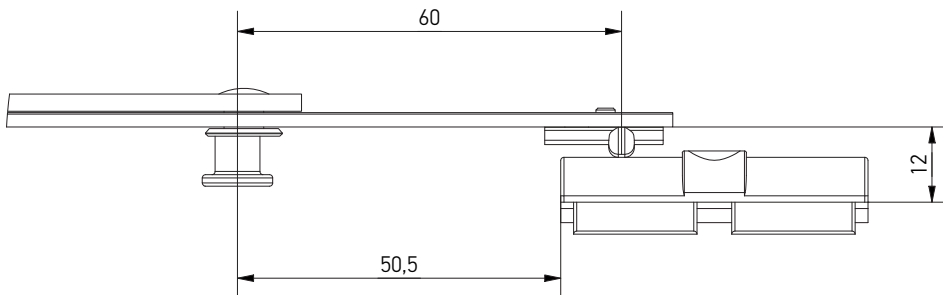
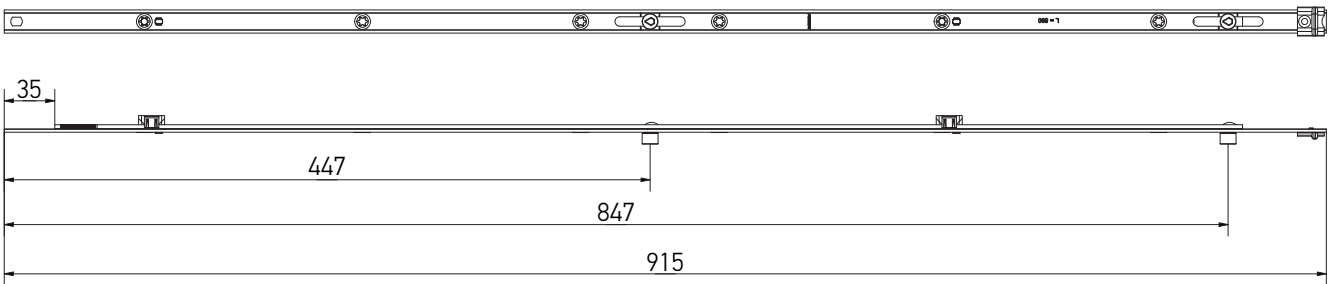

The extension locks K4062-XX-N03, K4063-XX-N03, K4066-XX-N03, K4067-XX-N03 use together with the suitable frame part A7237-XX-N03.

The suitable frame part [A7237-XX-N03] can be found on p. 207.

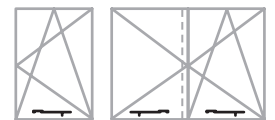

Найменування	Dimension				Part No.
Extension lock L = 480 mm, 1 ML, with sash lifter	515	1	5	20	K4066-05-N03
Extension lock L = 680 mm, 1 ML, with sash lifter	715	1	6	20	K4066-07-N03
Extension lock L = 880 mm, 2 ML, with sash lifter	915	2	8	20	K4066-09-N03
Frame part of sash lifter	Look at the section "Profile-dependent elements"				



**Extension lock with sash lifter, MR**

Corner transmissions  
Middle locks

Extension lock L = 480 mm, 1 MR, with sash lifter

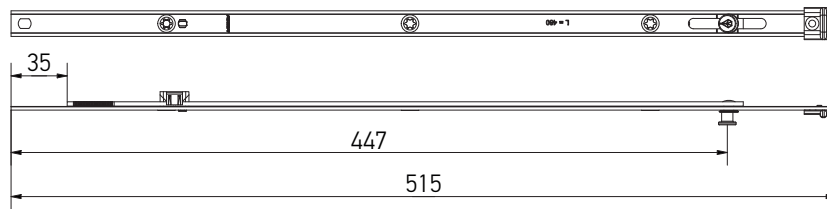

Extension lock L = 680 mm, 1 MR, with sash lifter

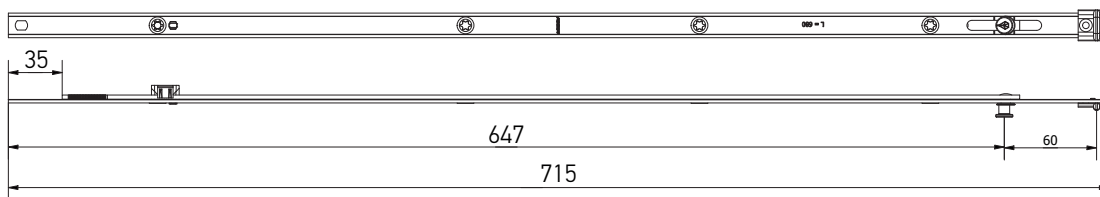

Extension lock L = 880 mm, 2 MR, with sash lifter

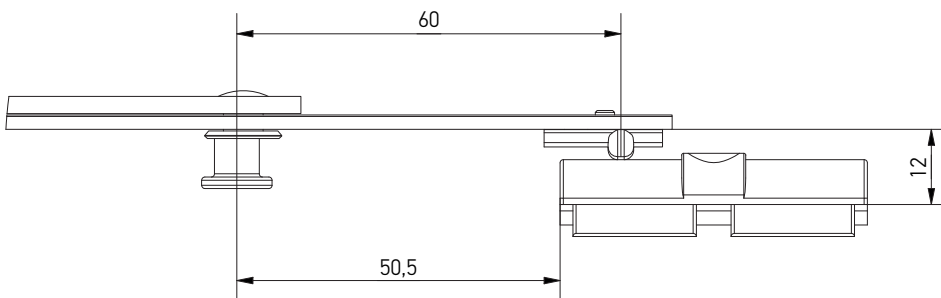
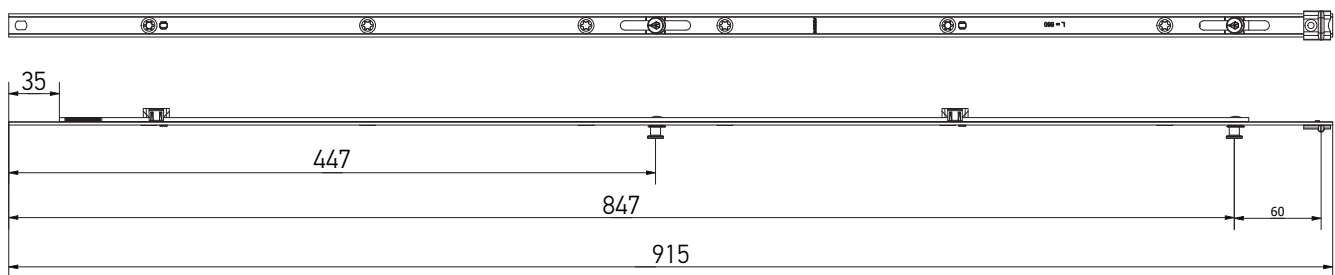

The extension locks K4062-XX-N03, K4063-XX-N03, K4066-XX-N03, K4067-XX-N03 use together with the suitable frame part A7237-XX-N03.

The suitable frame part (A7237-XX-N03) can be found on p. 207.

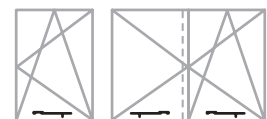

Description	Dimension				Part No.
Extension lock L = 480 mm, 1 MR, with sash lifter	515	1	5	20	K4067-05-N03
Extension lock L = 680 mm, 1 MR, with sash lifter	715	1	6	20	K4067-07-N03
Extension lock L = 880 mm, 2 MR, with sash lifter	915	2	8	20	K4067-09-N03
Frame part of sash lifter	Look at the section "Profile-dependent elements"				

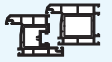

**Middle connection**

Corner transmissions  
Middle locks

Middle connection

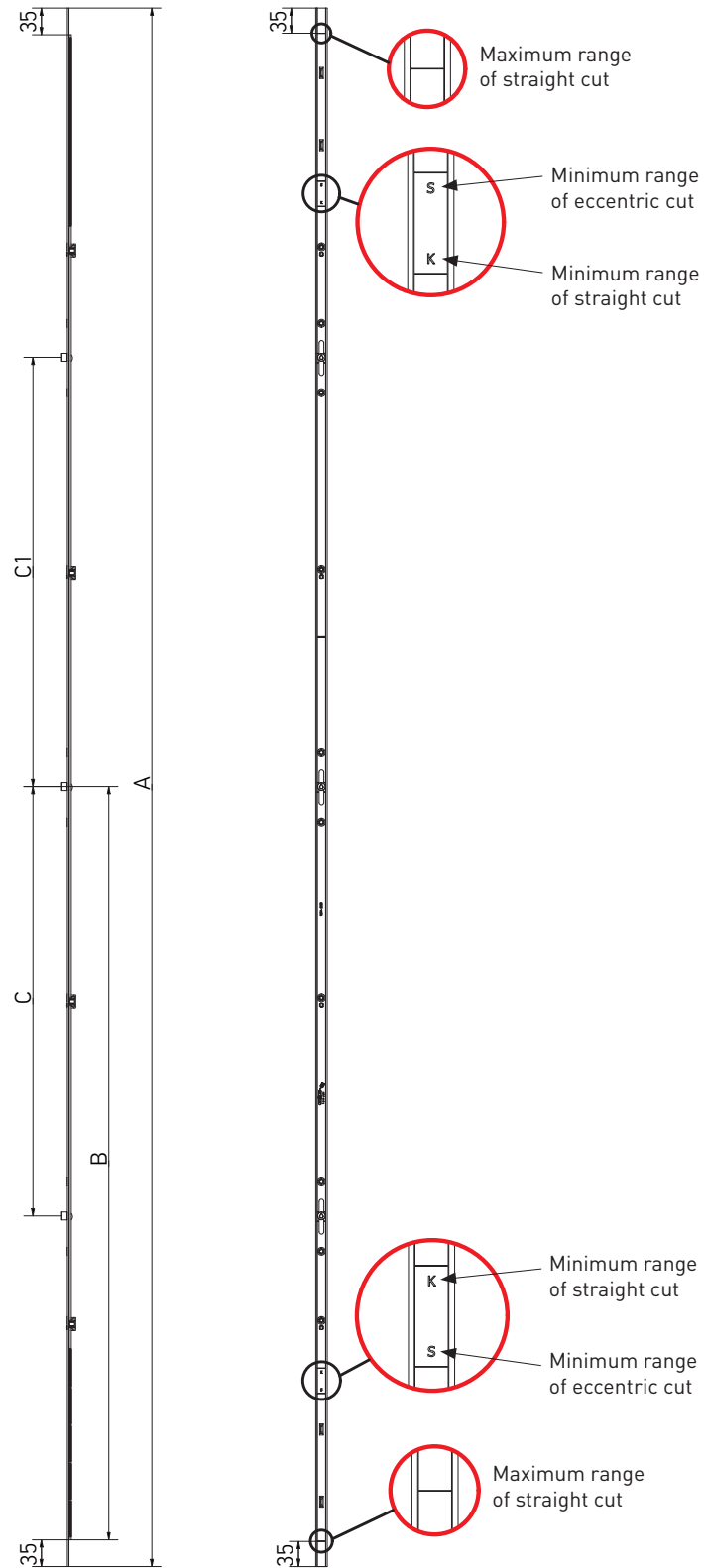

**Middle connection**

Description	SRW (mm)	Dimensions								Part No.
		A	B	C	C-1					
Middle connection L = 520, 551-750	551-750	520	225	—	—	—	—	2	20	K4013-05-N03
Middle connection L = 720, 751-950, 1 ML	751-950	720	325	—	—	1	—	4	20	K4013-07-N03
Middle connection L = 1200, 951-1430, 1 ML	951-1430	1200	565	—	—	1	—	4	20	K4013-11-N03
Middle connection L = 1680, 1431-1910, 2 ML	1431-1910	1680	805	330	330	2	—	8	10	K4013-16-N03
Middle connection L = 2160, 1911-2390, 3 ML	1911-2390	2160	1045	595	595	3	—	10	10	K4013-21-N03
Middle connection* L = 720, 751-950, 1 MR	751-950	720	325	—	—	—	1	4	20	K4033-07-N03
Middle connection* L = 1200, 951-1430, 1 MR	951-1430	1200	565	—	—	—	1	4	20	K4033-11-N03
Middle connection* L = 1680, 1431-1910, 2 MR	1431-1910	1680	805	330	330	—	2	8	10	K4033-16-N03
Middle connection* L = 2160, 1911-2390, 3 MR	1911-2390	2160	1045	595	595	—	3	10	10	K4033-21-N03

\* we offer security pins for different degree of protection





**Bottom extension**

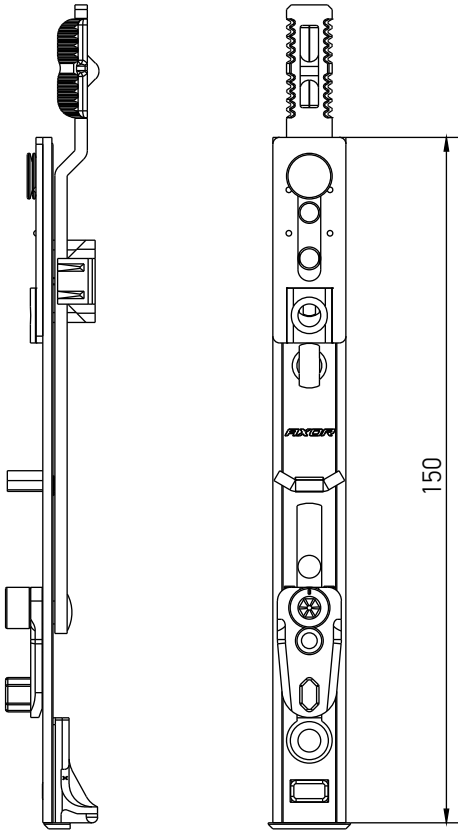

Corner transmissions  
Middle locks

Bottom extension

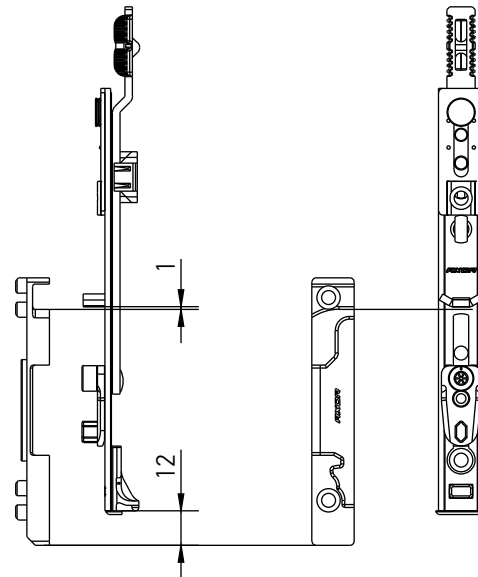
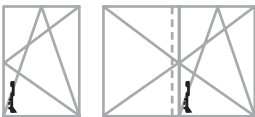

- not intended for RC security level;
- connection of middle lock is available.



Description	SRH (mm)			Part No.
Bottom extension	450-800	3	50	K4009-00-N03
Bottom extension	801-2390	3	50	K4002-00-N03



### Shoot bolt

Corner transmissions  
Middle locks

#### Shoot bolt

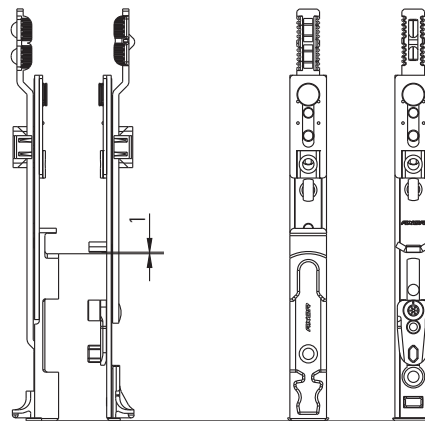
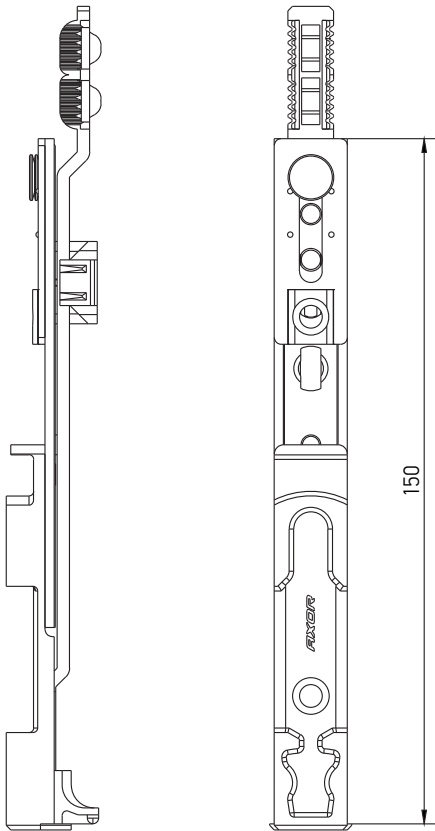

- latch outlet 11 mm;
- use with K1002-XX-N03 gear;
- not destined for safety level;
- connection of middle lock is available.

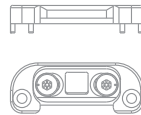
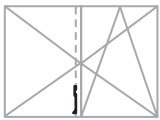

Description	SRW (mm)	SRH (mm)			Part No.
Shoot bolt (bottom)	400-1280	551-2390	3	50	K4006-00-N03

Description	Profile	Side opening	A	C	B			Part No.
Locking plate adjustable for shoot bolt	Rehau (13 mm), Aluplast, WDS, Veka	L/R	12	20	13	2	100	K6002-13-N03
Locking plate adjustable for shoot bolt	KBE (9 mm)	L/R	12	20	9	2	100	K6002-09-N03

A - sash rebate gap / C - sash overlap / B - sash groove position



**Shoot bolt**

Corner transmissions  
Middle locks

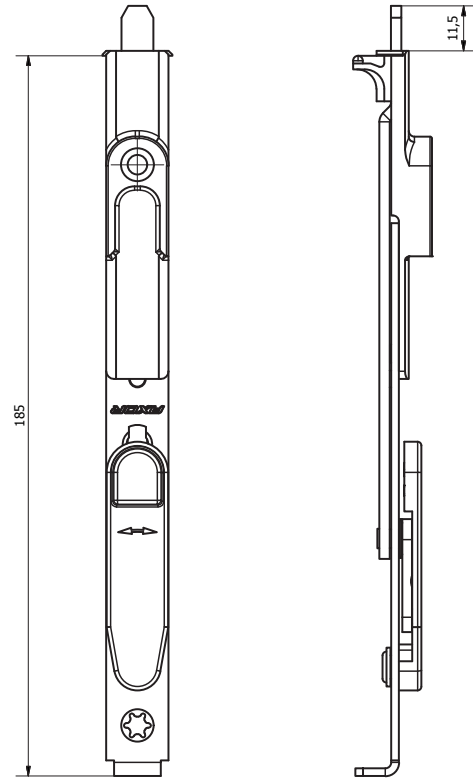
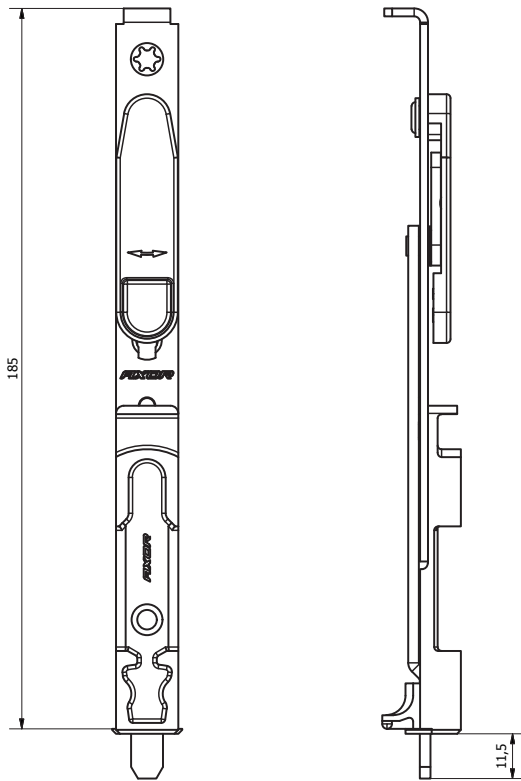

Shoot bolt, bottom

Shoot bolt, top

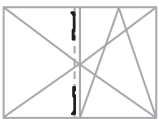

- latch outlet 11,5 mm;
- not destined for safety level;
- connection of middle lock is available.



Description	SRW (mm)	SRH (mm)			Part No.
Shoot bolt (bottom)	400-1280	551-2390	3	50	K4035-01-N03
Shoot bolt (top)	400-1280	551-2390	3	50	K4035-02-N03

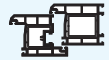

**Bottom extension for turn sash**

Corner transmissions  
Middle locks

Bottom extension for turn sash 180° (top), 1 ML

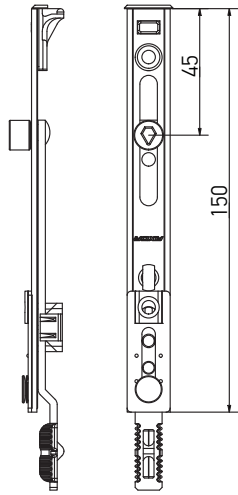

- connection of middle lock is available.

Bottom extension for turn sash 180° (top), 1 MR

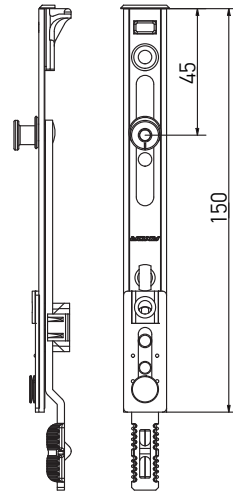

- connection of middle lock is available.

Bottom extension for turn sash 90° (top), 1 ML

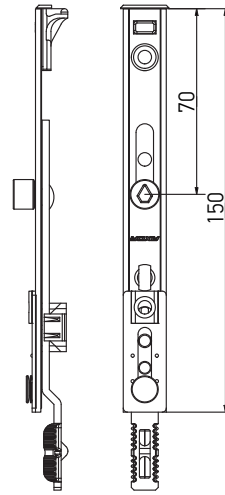

- connection of middle lock is available.

Bottom extension for turn sash 90° (bottom), 1 ML

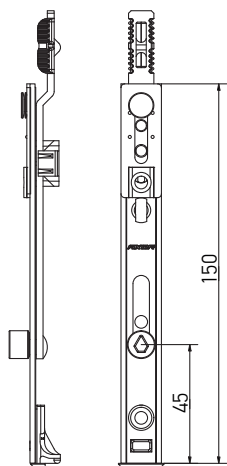

- connection of middle lock is available.

Bottom extension for turn sash 90° (bottom), 1 MR

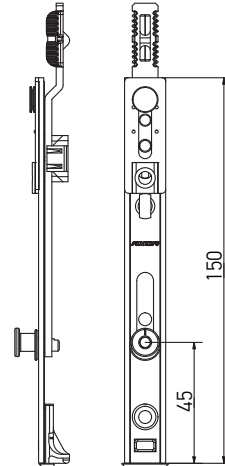

- connection of middle lock is available.

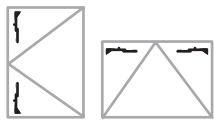

Description	SRH (mm)					Part No.
Bottom extension for turn sash 180° (top), 1 ML	450-2390	1	—	3	50	K4011-00-N03
Bottom extension for turn sash 90° (bottom), 1 ML	450-2390	1	—	3	50	K4007-00-N03
Bottom extension for turn sash 180° (top), 1 MR	450-2390	—	1	3	50	K4031-00-N03
Bottom extension for turn sash 90° (bottom), 1 MR	450-2390	—	1	3	50	K4027-00-N03
Bottom extension for turn sash 90° (top), 1 ML	450-2390	1	—	3	50	K4037-00-N03

**AXOR**<sup>®</sup>

**KOMFORT LINE K-3**

Smart&Quick

Stay arm

AXOR

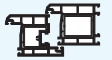

**Stay arm**

Stay arm

Stay arm

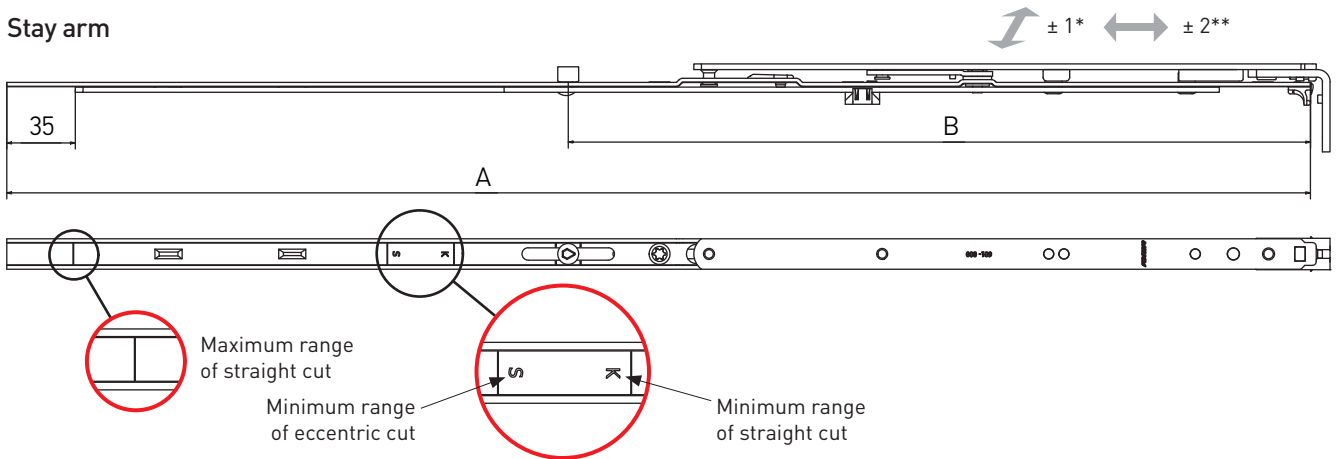

Stay arm, 1 MR

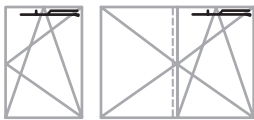
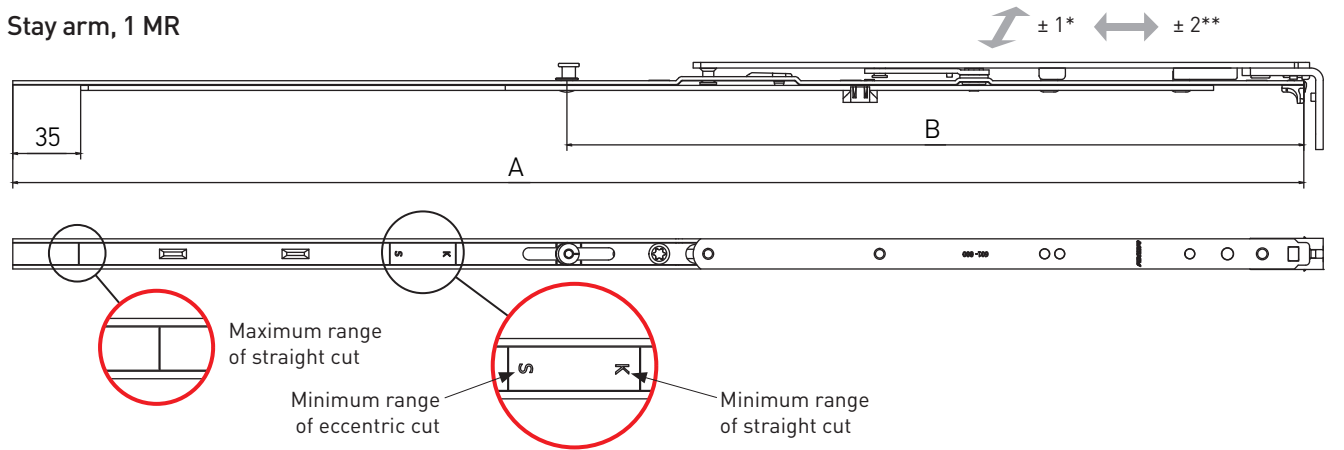

- for 18-22 mm sash overlap;  
- sash rebate gap min. 12 mm.

\* clamp adjustment, mm  
\*\* horizontal adjustment, mm

Description	SRW (mm)	Dimensions							Part No.
		A	B						
Stay arm 1, L=485, 400-600	400-600	485	—	—	—	130	3	20	K3001-05-N03
Stay arm 2, L=685, 601-800	601-800	685	—	—	—	130	4	20	K3001-07-N03
Stay arm 2, L=685, 601-800, 1 ML	601-800	685	390	1	—	130	4	18	K3001-57-N03
Stay arm 3, L=925, 801-1040, 1 ML	801-1040	925	537	1	—	130	6	20	K3001-09-N03
Stay arm 4, L=1165, 1041-1280, 1 ML	1041-1280	1165	624	1	—	130	7	20	K3001-11-N03
Stay arm 2, L=685, 601-800, 1 MR	601-800	685	390	—	1	130	4	18	K3021-57-N03
Stay arm 3, L=925, 801-1040, 1 MR	801-1040	925	537	—	1	130	6	20	K3021-09-N03
Stay arm 4, L=1165, 1041-1280, 1 MR	1041-1280	1165	624	—	1	130	7	20	K3021-11-N03



**Stay arm**

Stay arm

Stay arm

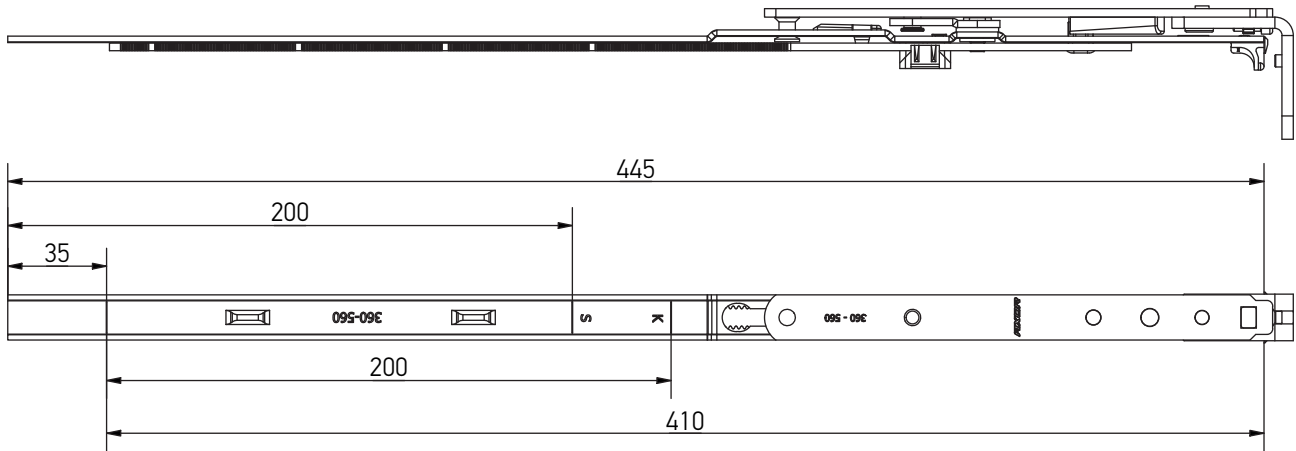

Possible mounting options

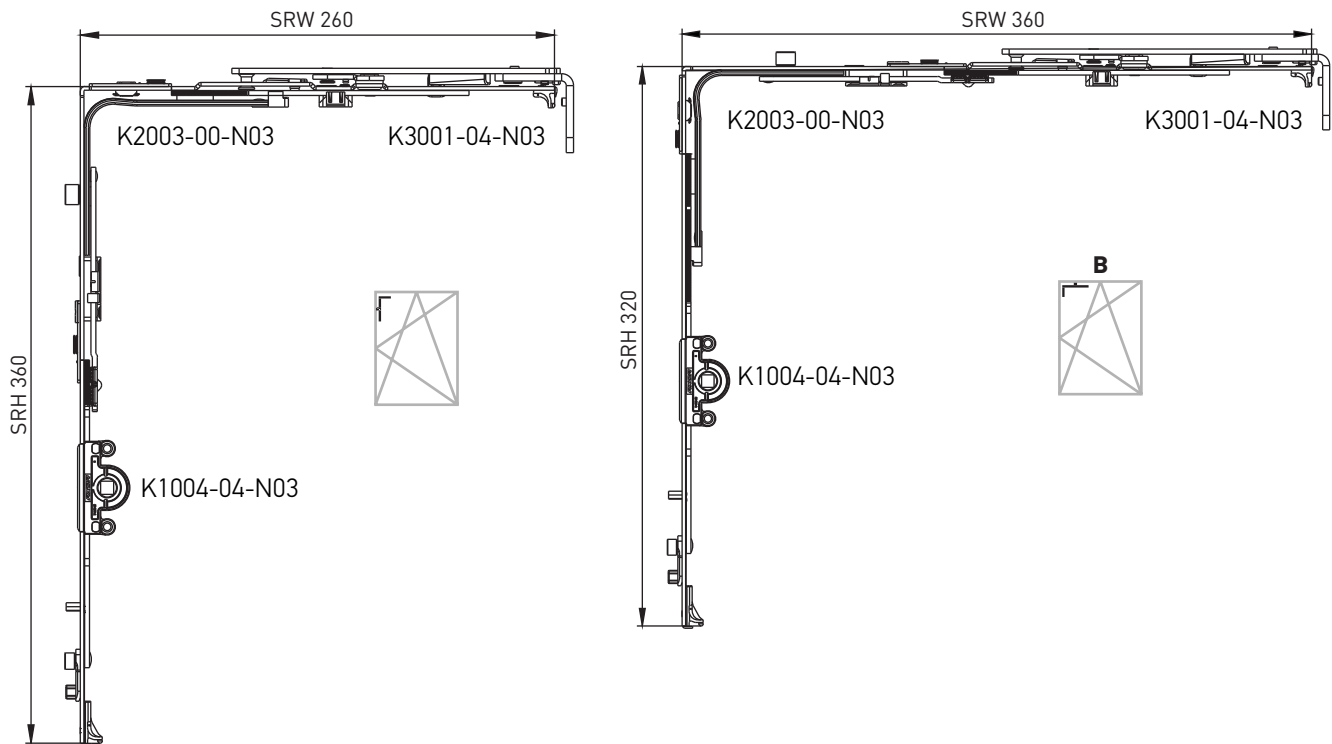

Description	SRW (mm)	Dimensions							Part No.
		A	B						
Stay arm 0, L=410, 360-560	360-560	410	—	—	—	130	3	20	K3001-04-N03



**Stay arm, sash part**

Stay arm

Stay arm, sash part

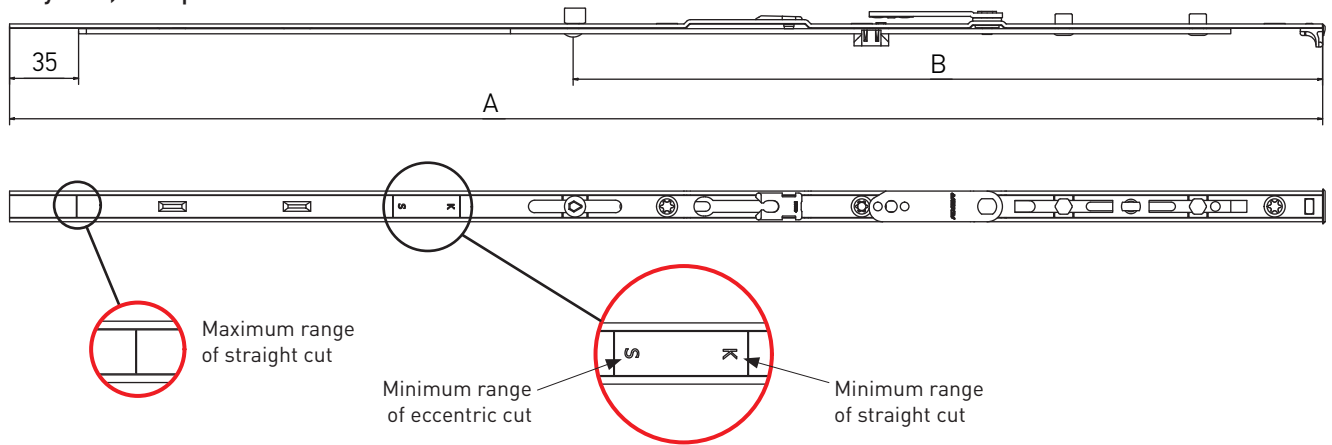

Stay arm, sash part, 1 MR

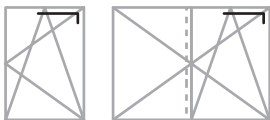
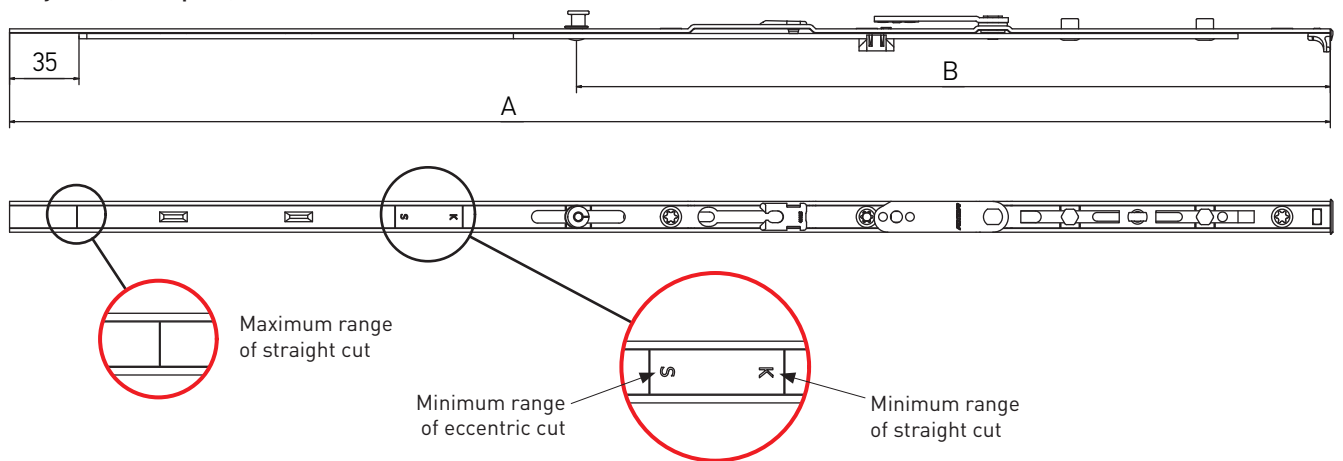

- for 18-22 mm sash overlap;  
- sash rebate gap min. 12 mm;

Description	SRW (mm)	Dimensions		Cylinder 1	Cylinder 2	kg	Screw	Box	Part No.
		A	B						
Stay arm, sash part, L= 485, 400-600	400-600	485	—	—	—	130	3	20	K3013-05-N03
Stay arm, sash part, L= 685, 601-800	601-800	685	—	—	—	130	4	20	K3013-07-N03
Stay arm, sash part, L= 685, 601-800, 1 ML	601-800	685	390	1	—	130	4	20	K3013-57-N03
Stay arm, sash part, L= 925, 801-1040, 1 ML	801-1040	925	537	1	—	130	6	10	K3013-09-N03
Stay arm, sash part, L= 1165, 1041-1280, 1 ML	1041-1280	1165	624	1	—	130	7	10	K3013-11-N03
Stay arm, sash part, L= 925, 801-1040, 1 MR	801-1040	925	537	—	1	130	6	10	K3023-09-N03
Stay arm, sash part, L= 1165, 1041-1280, 1 MR	1041-1280	1165	624	—	1	130	7	10	K3023-11-N03





Stay arm, frame part

Stay arm

Stay arm, frame part

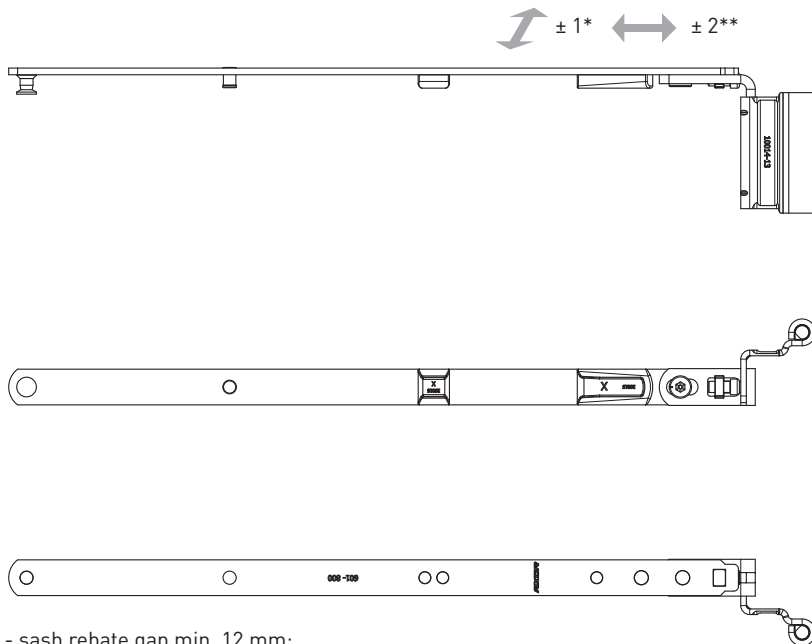

- sash rebate gap min. 12 mm;

\* clamp adjustment, mm

\*\* horizontal adjustment, mm

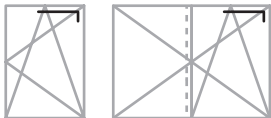

Description	SRW (mm)	Side opening	A	C	B	kg	Box	Part No.
Stay arm, frame part 13, L=248, 400-600, left	400-600	L	12	20	13	130	10	K3011-02-L03
Stay arm, frame part 13, L=248, 400-600, right	400-600	R	12	20	13	130	10	K3011-02-R03
Stay arm, frame part 13, L=319, 601-800, left	601-800	L	12	20	13	130	10	K3011-03-L03
Stay arm, frame part 13, L=319, 601-800, right	601-800	R	12	20	13	130	10	K3011-03-R03
Stay arm, frame part 13, L=449, 801-1040, left	801-1040	L	12	20	13	130	10	K3011-04-L03
Stay arm, frame part 13, L=449, 801-1040, right	801-1040	R	12	20	13	130	10	K3011-04-R03
Stay arm, frame part 13, L=539, 1041-1280, left	1041-1280	L	12	20	13	130	10	K3011-05-L03
Stay arm, frame part 13, L=539, 1041-1280, right	1041-1280	R	12	20	13	130	10	K3011-05-R03



Stay arm "First Tilt"\*

Stay arm

Stay arm "First Tilt"\*

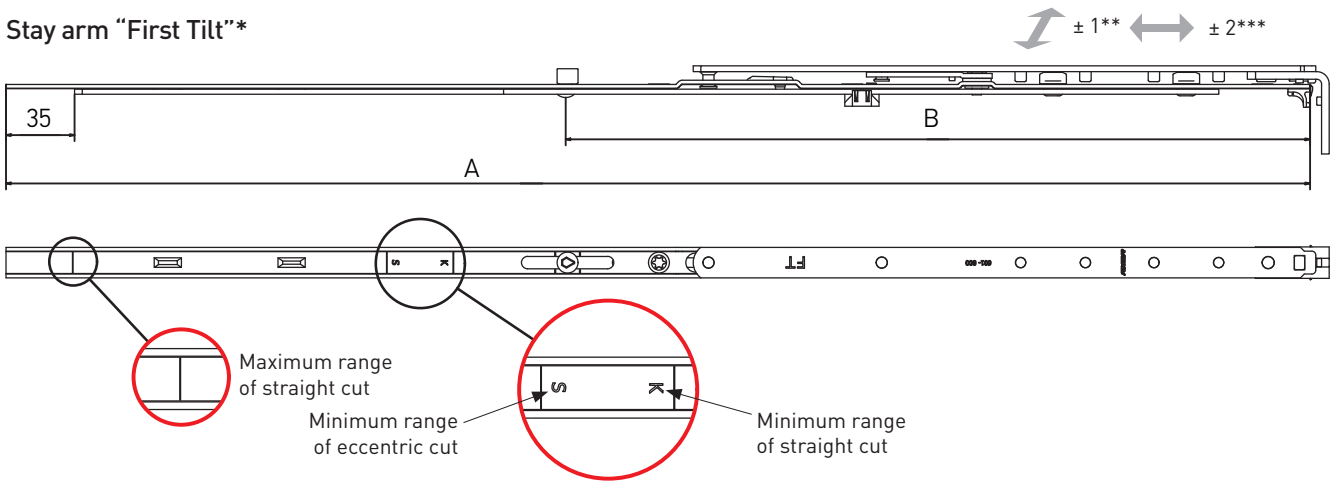

Stay arm "First Tilt"\*, 1 MR

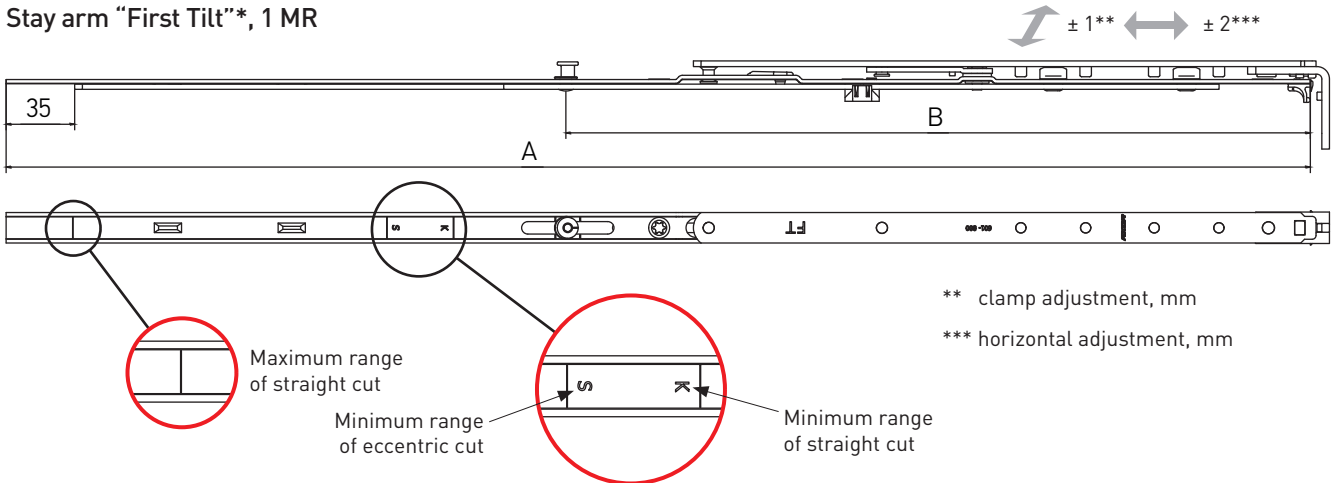

\*\* clamp adjustment, mm  
\*\*\* horizontal adjustment, mm

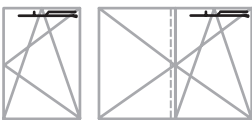

- for 18-22 mm sash overlap;
- sash rebate gap min. 12 mm;
- they are used together with corner transmission and a special tilt locking plate instead of the bottom extension [see: "Hardware set combinations" section].

Description	SRW (mm)	Dimensions							Part No.
		A	B						
Stay arm 1, "First Tilt", L=485, 400-600	400-600	485	—	—	—	130	3	20	K3014-05-N03
Stay arm 2, "First Tilt", L=685, 601-800	601-800	685	—	—	—	130	4	20	K3014-07-N03
Stay arm 3, "First Tilt", L=915, 801-1040, 1 ML	801-1040	915	537	1	—	130	6	10	K3014-09-N03
Stay arm 4, "First Tilt", L=1165, 1041-1280, 1 ML	1041-1280	1165	624	1	—	130	7	10	K3014-11-N03
Stay arm 3, "First Tilt", L=915, 801-1040, 1 MR	801-1040	915	537	—	1	130	6	10	K3024-09-N03
Stay arm 4, "First Tilt", L=1165, 1041-1280, 1 MR	1041-1280	1165	624	—	1	130	7	10	K3024-11-N03

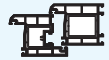

Turn stay arm

Stay arm

Turn stay arm

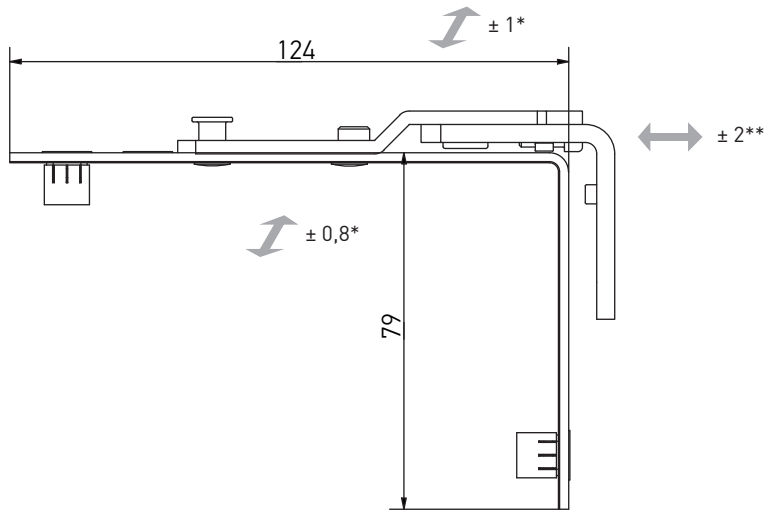

Turn stay arm

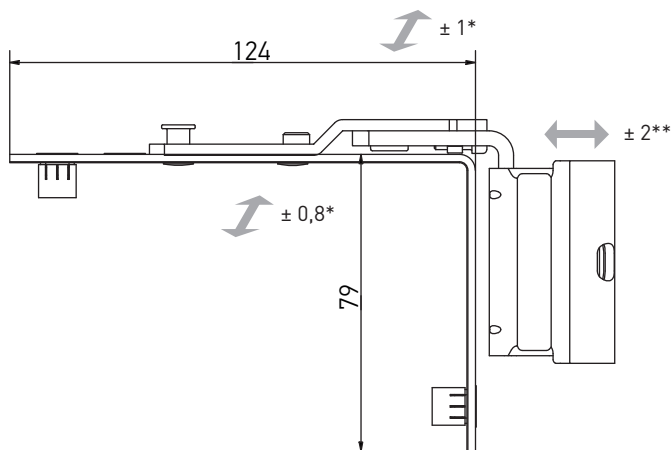

\* clamp adjustment, mm

\*\* horizontal adjustment, mm

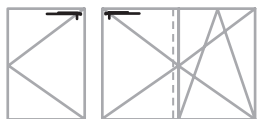

Description	SRW (mm)					Part No.
Turn stay arm	280-1280	0	4	100	100	K5002-00-N03
Turn stay arm 12/20-13 left	280-1200	0	3	100	25	K5014-13-L03
Turn stay arm 12/20-13 right	280-1200	0	3	100	25	K5014-13-R03
Turn stay arm 12/20-9 left	280-1200	0	3	100	25	K5014-09-L03
Turn stay arm 12/20-9 right	280-1200	0	3	100	25	K5014-09-R03



**Tilt stay arm**

Stay arm

Tilt stay arm

General view and stay-arm position at a frame

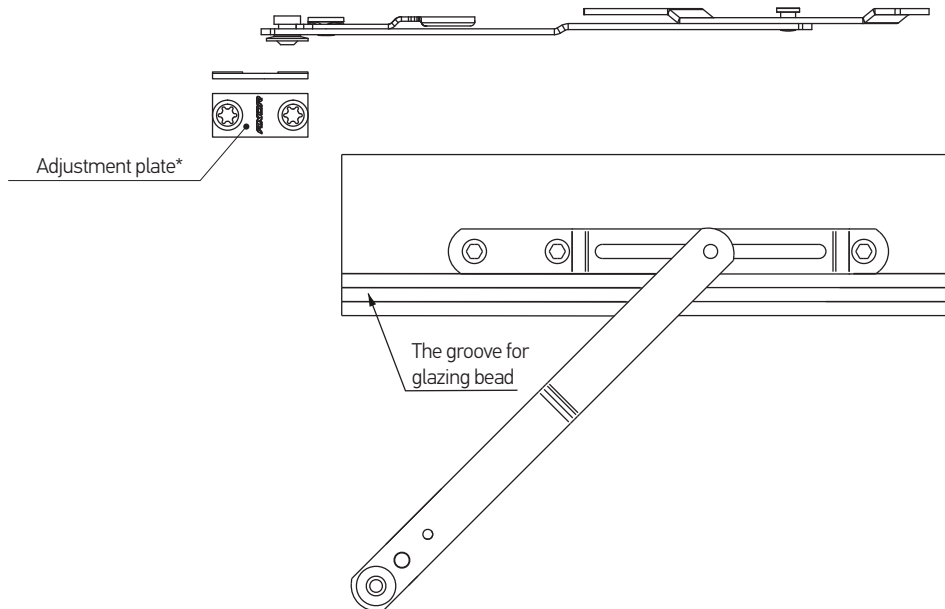

Information for installation

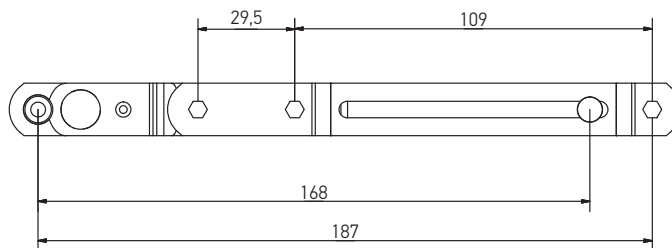
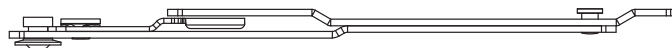

Description	SRW (mm)					Part No.
Tilt stay arm	450-1710	0	3	45	100	A7017-00-N03
Adjustment plate for the tilt stay arm	—	—	—	—	—	A7039-00-N03

\* - To install stay arm vertically



# Tilt stay arm

Stay arm

## Tilt stay arm

General view and stay-arm position at a frame

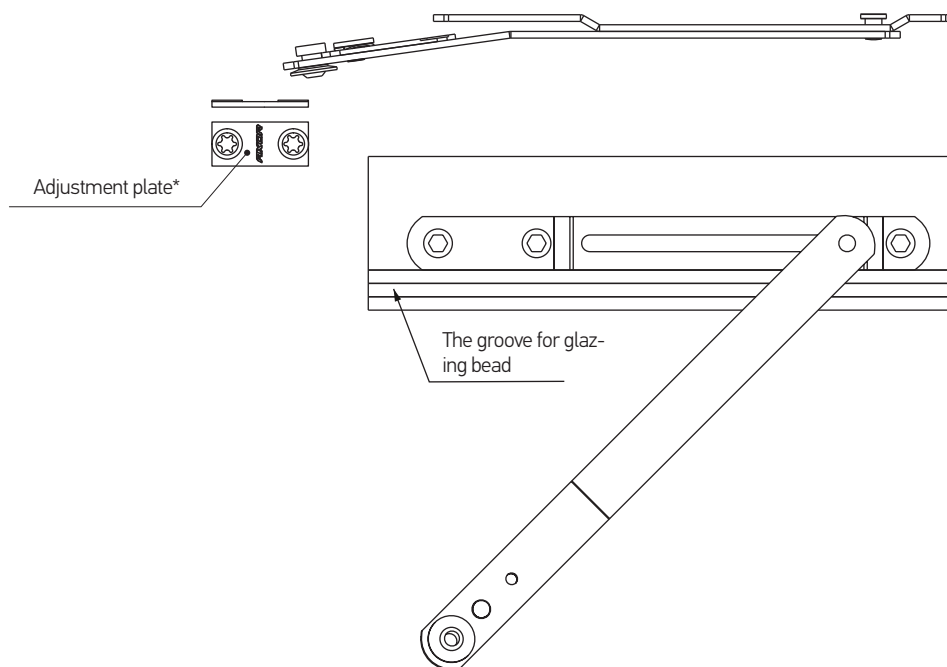

## Information for installation

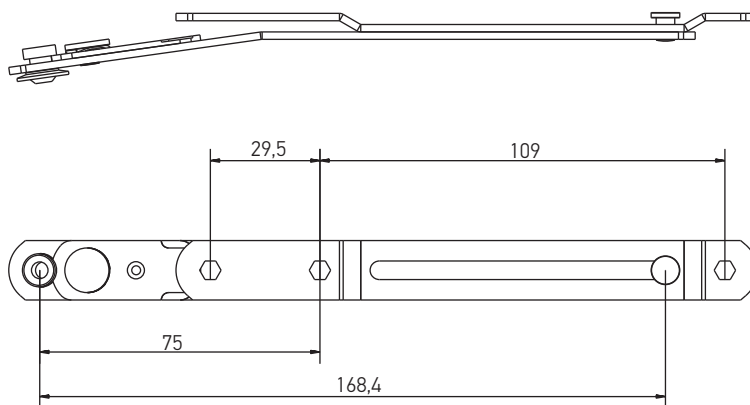

Description	SRW (mm)					Part No.
Tilt stay arm	450-1710	0	3	45	100	A7107-00-N03
Adjustment plate for the tilt stay arm	—	—	—	—	—	A7039-00-N03

\* - To install stay arm vertically



**Additional stay arm**

Stay arm

**Additional stay arm, frame part**



- installation when the sash rebate width is from 1200 mm
- for left and right opening
- profile-depending element

**Additional stay arm, sash part**

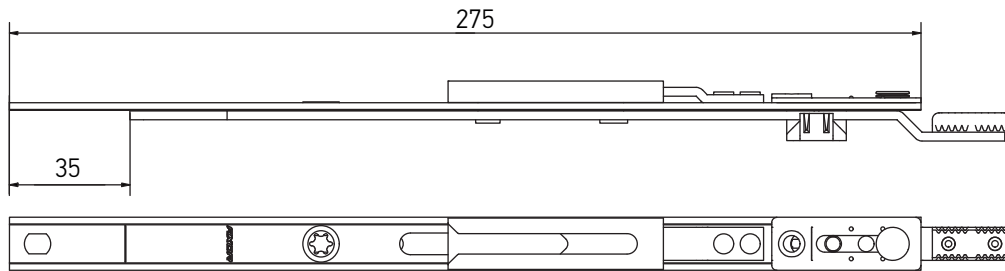

- installation when the sash rebate width is from 1200 mm
- for left and right opening

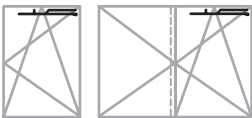

Description	SRW (mm)			kg		Part No.
Additional stay arm, frame part, 1200-1520 (ALUPLAST)	1200-1520	—	2	130	20	K3015-00-N03
Additional stay arm, frame part, 1200-1520 (WDS)	1200-1520	—	2	130	20	K3015-01-N03
Additional stay arm, frame part, 1200-1520 (GEALAN)	1200-1520	—	2	130	20	K3015-02-N03
Additional stay arm, sash part, L=275, 1200-1520	1200-1520	—	2	130	20	K3016-00-N03

**AXOR**<sup>®</sup>

**KOMFORT LINE K-3**

Smart&Quick

Additional elements

AXOR



**Wrong operation safety device with sash lifter**

Additional elements

Wrong operation safety device with sash lifter

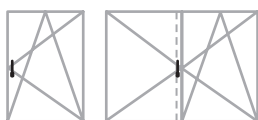
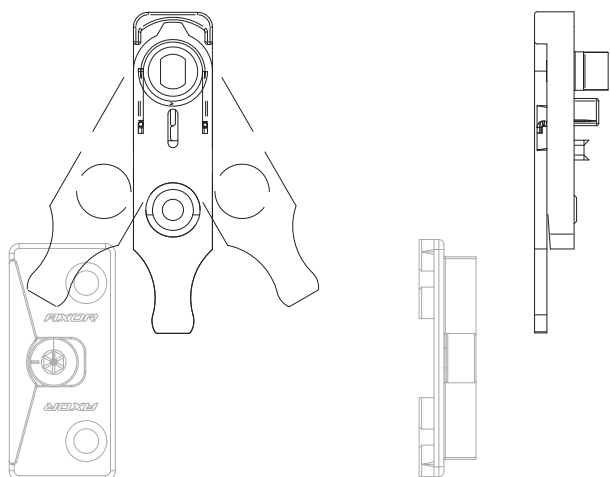

Description	Side opening	A	C	B	kg			Part No.
Wrong operation safety device with sash lifter	L/R	—	—	—	—	1	100	A7001-00-N03
Lifting plate	Look at the section "Profile-dependent elements"							
Lifting plate plate for double-sash window	L/R	12	—	09-13	—	2	250	A6001-00-N03

A - sash rebate gap / C - sash overlap / B - sash groove position





# Single sash lifter

## Additional elements

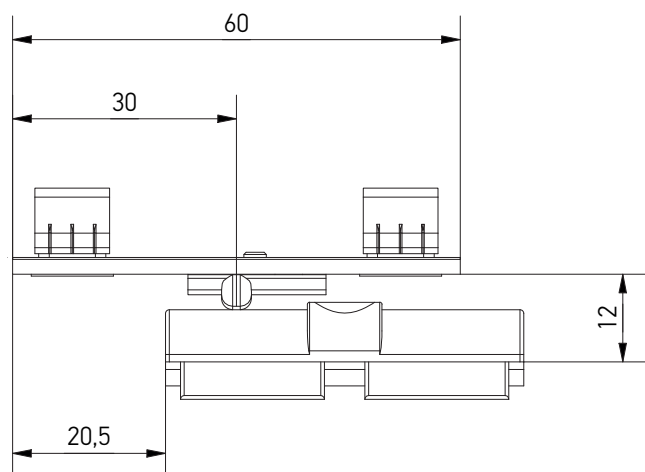
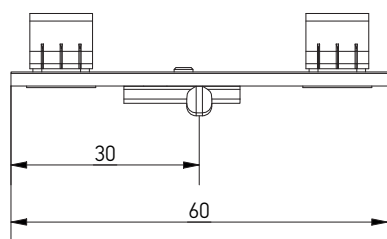
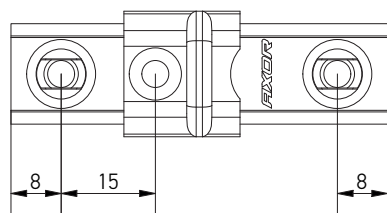

### Single sash lifter



The single sash lifter A7236-00-N03 use together with the suitable frame part A7237-XX-N03.

The suitable frame part (A7237-XX-N03) can be found on p. 207.



Description	Dimensions			Part No.
Single sash lifter	60	3	100	A7236-00-N03
Frame part of sash lifter	Look at the section "Profile-dependent elements"			



**Locking plate, integrated slit**

Additional elements

Locking plate, integrated slit

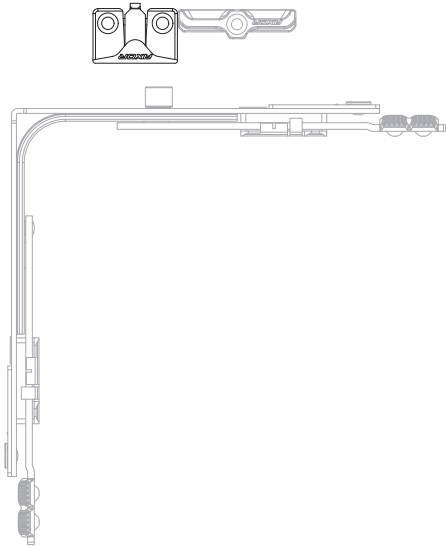

- use with standard and narrow corner transmissions;
- independent from type of opening (left or right);
- creates a 7-mm gap for ventilation;
- recommended for using with 8-position handle.

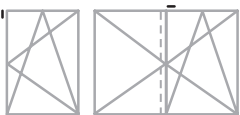
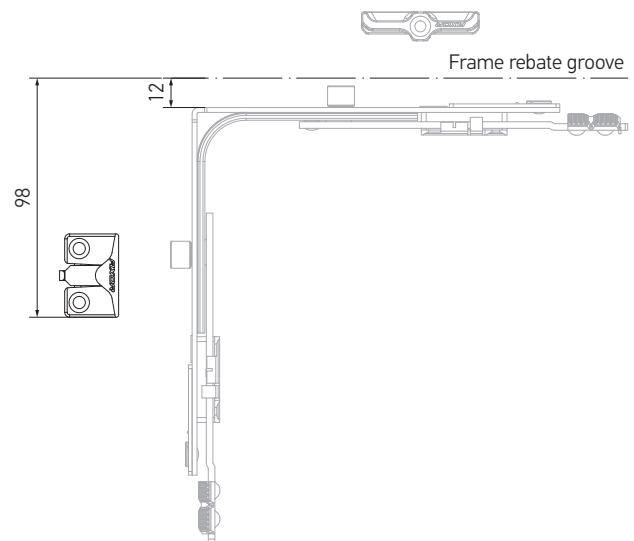

Description	Profile	Side opening	A	C	B			Part No.
Locking plate, integrated slit	Profile-dependent element*	L/R	12	—	9	2	100	A6005-09-N03
Locking plate, integrated slit	Profile-dependent element*	L/R	12	—	13	2	200	A6002-13-N03

\*For part No. numbers of other components look at the section "Profile-dependent elements"

A - sash rebate gap / C - sash overlap / B - sash groove position

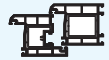

**Balcony catch**

Additional elements

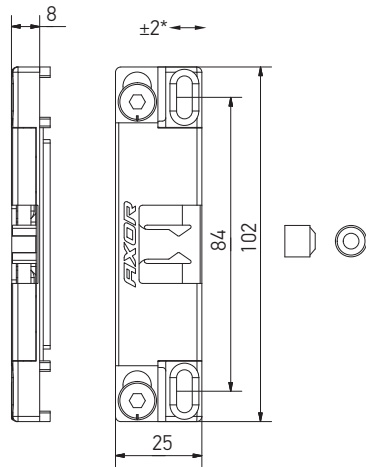

**Balcony catch**

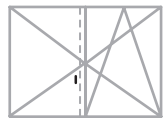
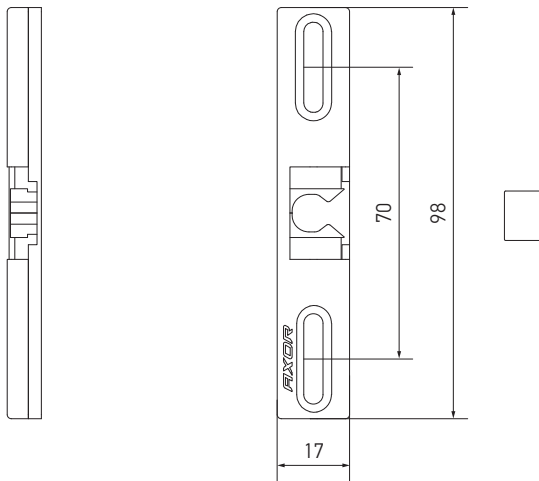

\* the ability to adjust the fit

**Balcony catch for double-sash gear M**



Description	Side opening	A	C	B			Part No.
Balcony catch	L/R	12	—	13	2 / 4x35	100	A7184-13-N03
Balcony locking pin	—	—	—	—	1 / 4x30	1000	A7207-00-N00
Balcony catch for double-sash gear M	L/R	—	—	—	2 / 4x30	50	A7047-00-N03

A - sash rebate gap / C - sash overlap / B - sash groove position



**Magnetic balcony catch**

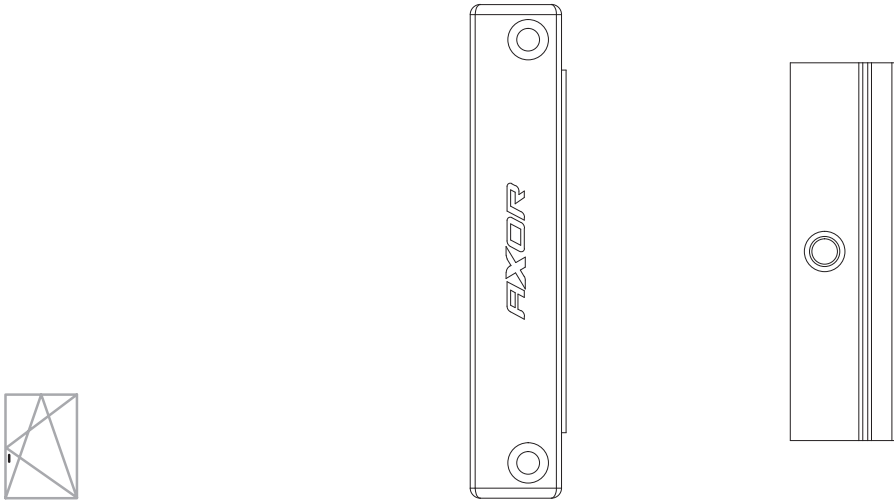

Additional elements

Magnetic balcony catch

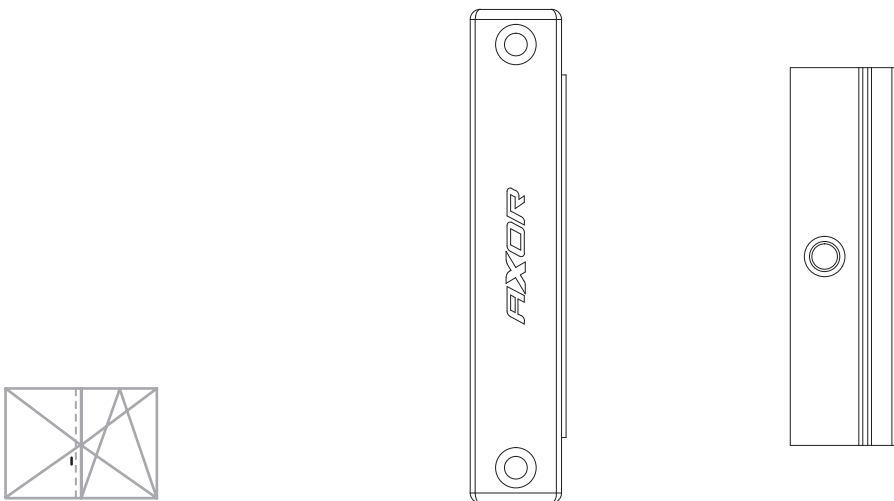

Magnetic balcony catch for double-sash gear



Description	Side opening	A	C	B			Part No.
Magnetic balcony catch, frame part	L/R	12	20	—	2 / 4×35	100	A7053-00-N03
Magnetic balcony catch, sash part, 13 th system	L/R	—	—	13	1/4×30	100	A7055-13-N03
Magnetic balcony catch, sash part, 9 th system	L/R	—	—	9	1/4×30	100	A7055-09-N03
Magnetic balcony catch for double-sash gear, frame part	L/R	—	—	—	2 / 4×30	100	A7054-00-N03

A - sash rebate gap / C - sash overlap / B - sash groove position



**Concealed middle hinge**

Additional elements

**Concealed middle hinge, frame part**

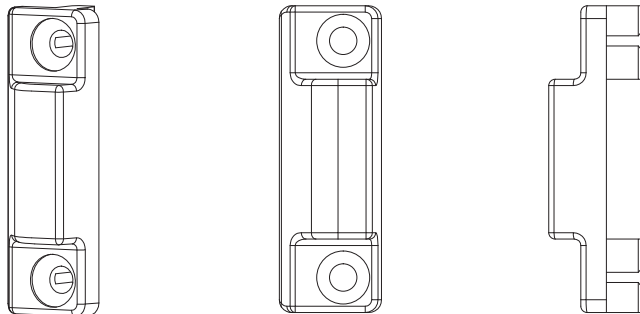

**Concealed middle hinge, sash part**

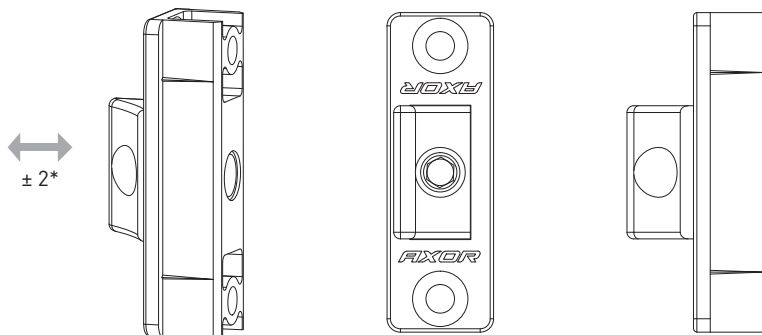

\* horizontal adjustment, mm

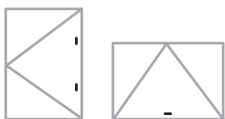

Description	SRH/SRW (mm)		A	C	B			Part No.
Concealed middle hinge frame part 12/20-13	751-1710	1						
	1711-2360	2	12	20	13	2 / 4×35	100	A7057-13-N03
Concealed middle hinge frame part 12/20-9	751-1710	1						
	1711-2360	2	12	20	9	2 / 4×35	100	A7057-09-N03
Concealed middle hinge sash part	751-1710	1	—	—	—	2 / 4×25	100	A7056-00-N03
	1711-2360	2						

A - sash rebate gap / C - sash overlap / B - sash groove position



**Middle hinge**

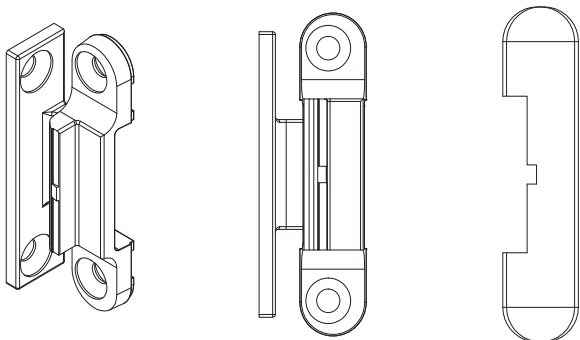

Additional elements

Middle hinge

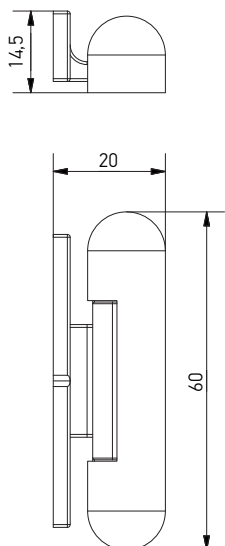

Middle hinge



Description	SRH/SRW (mm)				Part No.
Middle hinge, white	751-1710	1	4 / 4x25	100	A7185-00-N01
	1711-2360	2			
Middle hinge, brown	751-1710	1	4 / 4x25	100	A7185-00-N02
	1711-2360	2			
Middle hinge, gray anthracite	751-1710	1	4 / 4x25	100	A7185-00-N09
	1711-2360	2			



**Stroke limiter 90°**

Additional elements

Stroke limiter 90°

Stroke limiter 90° made of ZAMAK alloy

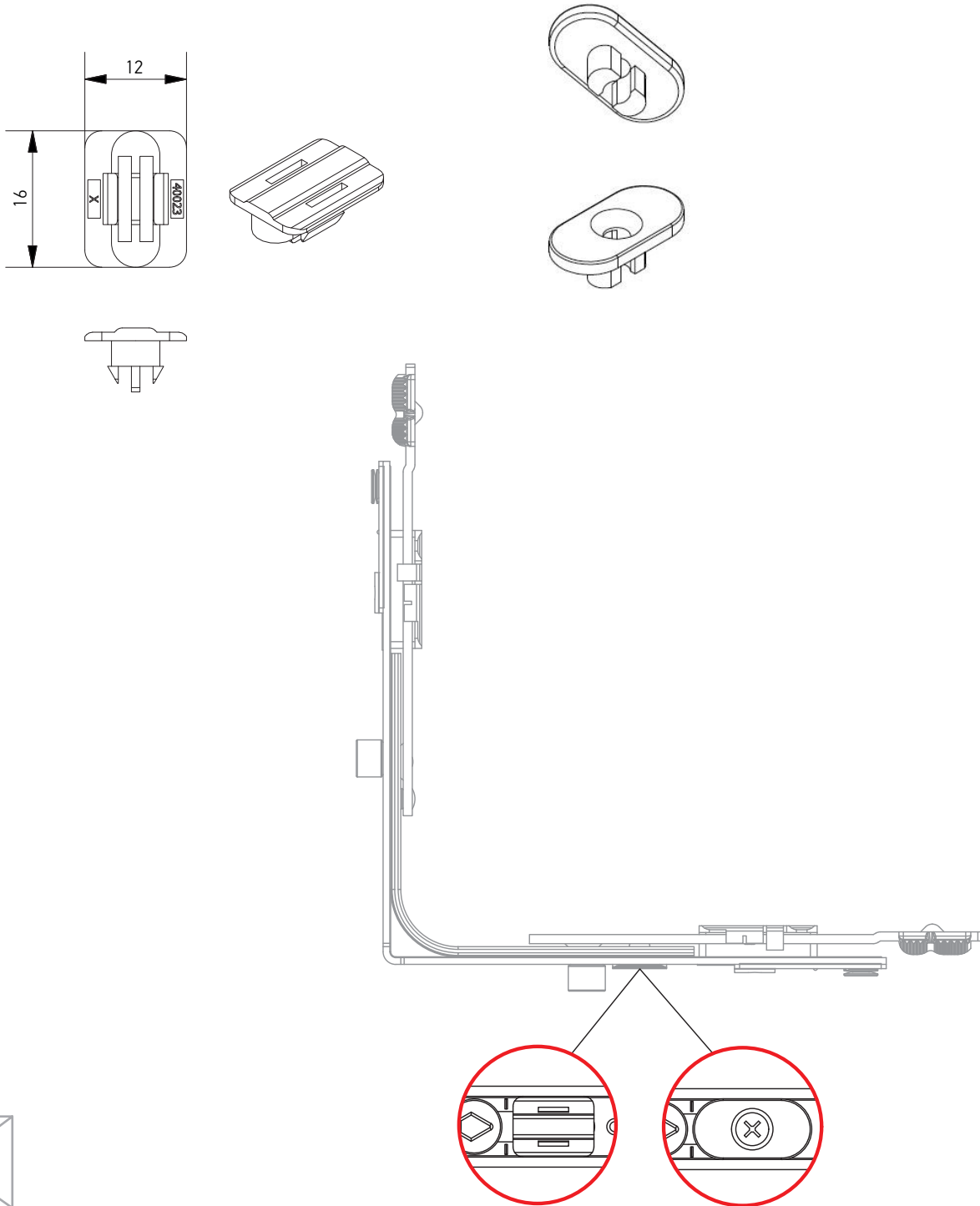

Description		Part No.
Stroke limiter 90°	4000	A7052-00-N03
Stroke limiter 90° made of ZAMAK alloy	1000	A7103-00-N03

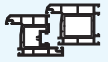

**Cover for gear with customer logo**

Additional elements

Cover for gear with customer logo, S

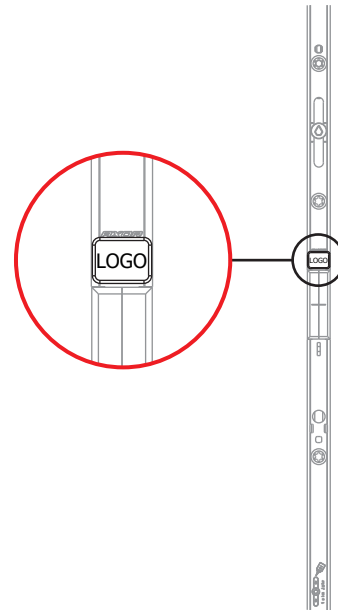
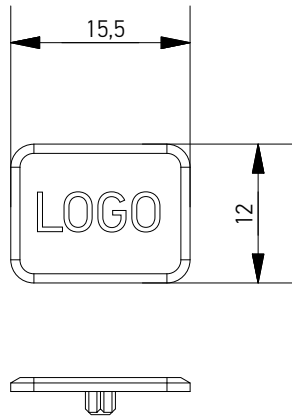

Cover for gear with customer logo, M

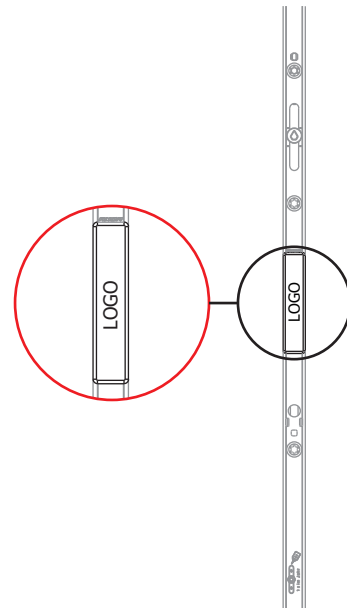
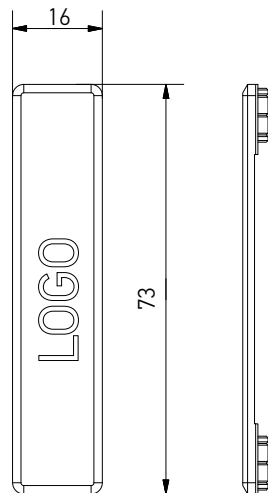

Description		Part No.
Cover for gear with customer logo, S	4000	A7060-00-N03
Cover for gear with customer logo, M	500	40001-00-N09





**Protective plate for gear**

Additional elements

Protective plate for gear

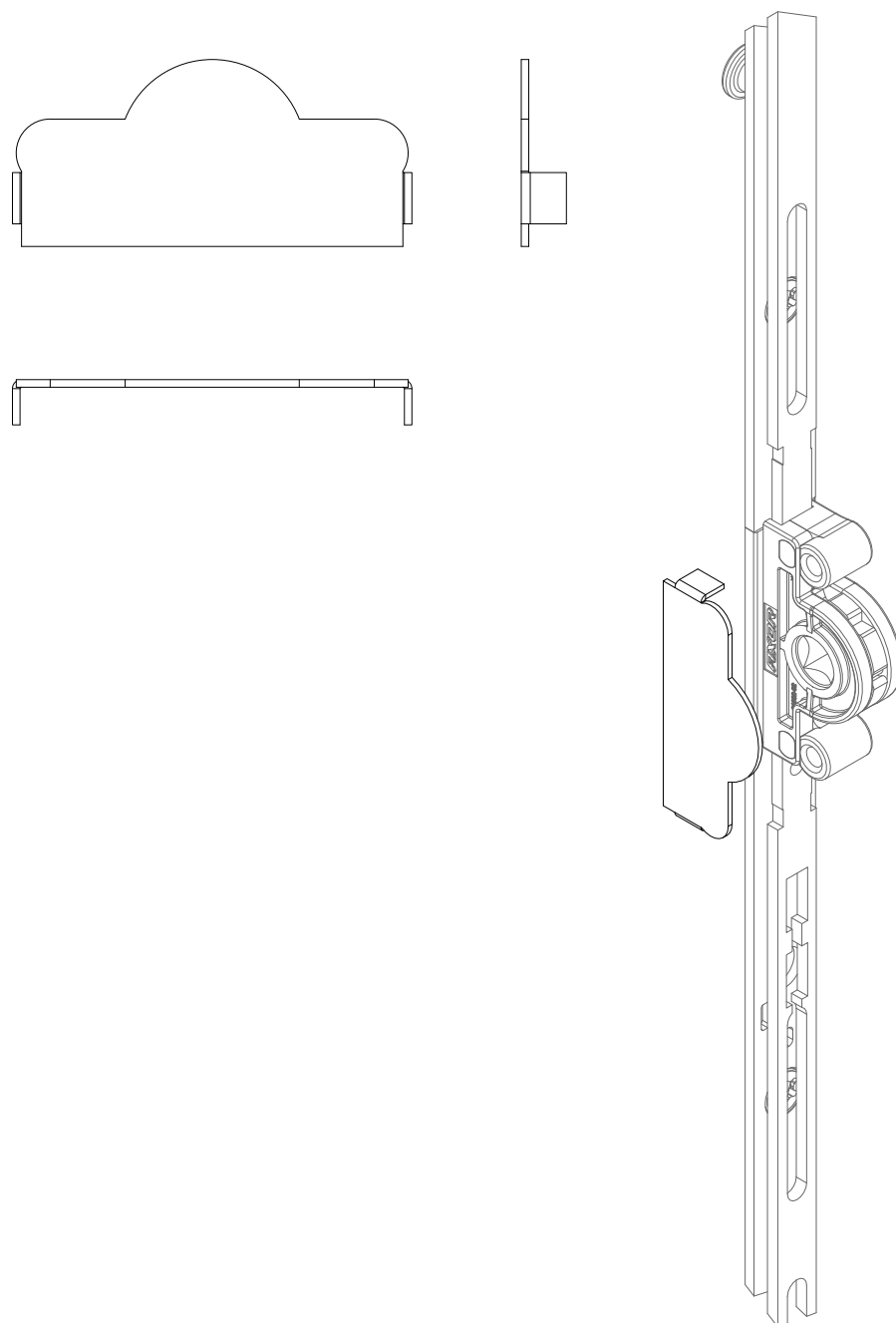

**Description**

Protective plate for gear



250

**Part No.**

A7061-00-N03

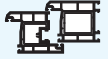

**Stroke limiter**

Additional elements

Stroke limiter

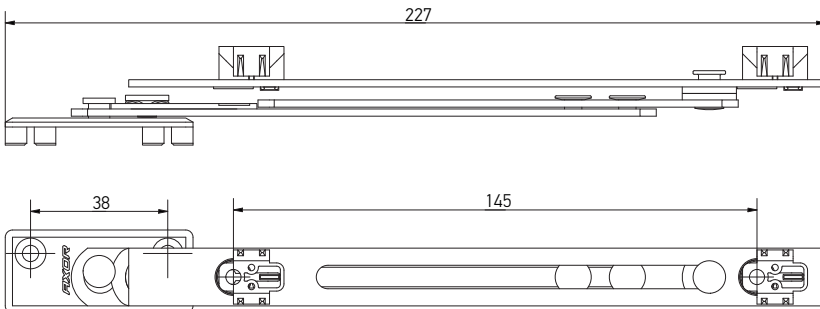

Possible mounting options with visible hinges

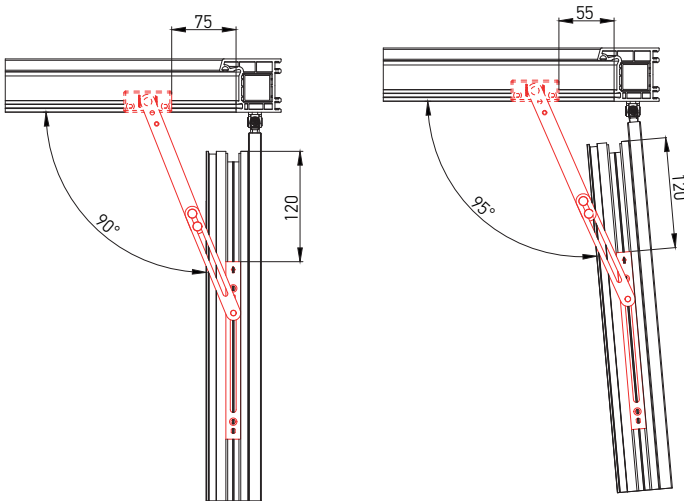

Possible mounting options with concealed hinges

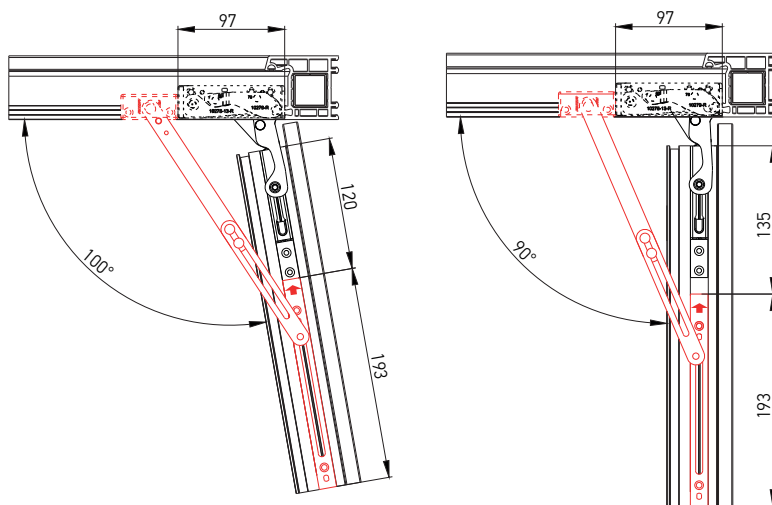

Description				Part No.
Stroke limiter	4	100	50	A7110-00-N03



**AXOR**<sup>®</sup>

**KOMFORT LINE K-3**

Smart&Quick

Hardware set combinations

AXOR



**Tilt and turn set**

Hardware set combinations

Tilt and turn set, straight cut.

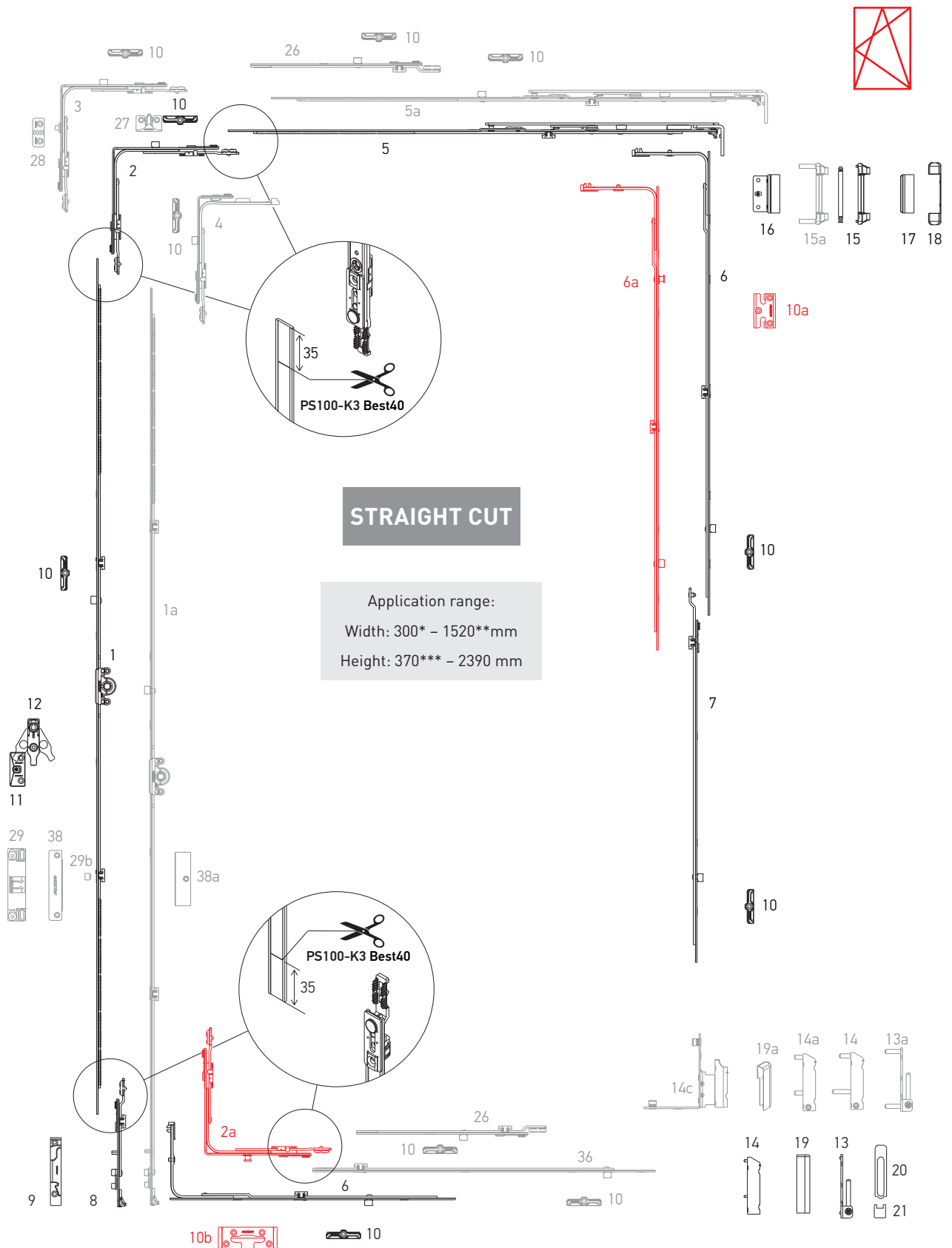

\* with narrow corner transmission  
\*\* with the linear extension 240 mm  
\*\*\* with the constant gear K1004-04-N03



## Tilt and turn set

## Hardware set combinations

## STRAIGHT CUT

Nº	Description	Application range by width	Application range by height	Part No.
1	Gear variable 0, L=320, 450-550	—	450-550	K1001-02-N03
	Gear variable 1, L=520, 551-750	—	551-750	K1001-04-N03
	Gear variable 2, L=1000, 751-1230, 1 ML	—	751-1230	K1001-09-N03
	Gear variable 3, L=1200, 950-1430, 1 ML	—	950-1430	K1001-11-N03
	Gear variable 4, L=1480, 1231-1710, 2 ML	—	1231-1710	K1001-14-N03
	Gear variable 5, L=1680, 1431-1910, 2 ML	—	1431-1910	K1001-16-N03
	Gear variable 6, L=2160, 1911-2390, 3 ML	—	1911-2390	K1001-21-N03
1a	Constant gear 0, L=435, G=140, 370-550*	—	370-550	K1004-04-N03
	Constant gear 1, L=385, G=175, 400-500*	—	400-500	K1004-03-N03
	Constant gear 2, L=565, G=200, 480-680*	—	480-680	K1004-05-N03
	Constant gear 3, L=805, G=300, 681-920*, 1 ML	—	681-920	K1004-08-N03
	Constant gear 4, L=1045, G=450, 921-1160*, 1 ML	—	921-1160	K1004-10-N03
	Constant gear 5, L=1285, G=600, 1161-1400*, 1 ML	—	1161-1400	K1004-12-N03
	Constant gear 6, L=1525, G=600, 1401-1640*, 2 ML	—	1401-1640	K1004-15-N03
	Constant gear 7, L=1765, G=600, 1641-1880*, 2 ML	—	1641-1880	K1004-17-N03
	Constant gear 8, L=1765, G=1000, 1641-1880*, 2 ML	—	1641-1880	K1004-18-N03
	Constant gear 9, L=2005, G=1000, 1881-2120*, 2 ML	—	1881-2120	K1004-20-N03
	Constant gear 10, L=2245, G=1000, 2121-2360*, 3 ML	—	2121-2360	K1004-22-N03
2	Corner transmission, 1 ML, 150×150	400-1280	450-2390	K2001-00-N03
2a	Corner transmission, 1 MR, 150×150	400-1280	450-2390	K2005-00-N03
3	Corner transmission, integrated slit, 1 ML, 150×150, left	400-1280	450-2390	K2004-00-L03
	Corner transmission, integrated slit, 1 ML, 150×150, right	400-1280	450-2390	K2004-00-R03
4	Narrow corner transmission, 1 ML, 50×150	300-400	450-2390	K2003-00-N03
		400-600	370-550*	
5	Stay arm 1, L=485, 400-600	400-600	—	K3001-05-N03
	Stay arm 2, L=685, 601-800	601-800	—	K3001-07-N03
	Stay arm 3, L=925, 801-1040, 1 ML	801-1040	—	K3001-09-N03
	Stay arm 4, L=1165, 1041-1280, 1 ML	1041-1280	—	K3001-11-N03
5a	Stay arm 2, L=685, 601-800, 1 ML	601-800	—	K3001-57-N03
6	Middle lock L=400, 1 ML	600-1000	600-1000	K4001-04-N03
	Middle lock L=650, 1 ML	850-1250	850-1250	K4001-06-N03
	Middle lock L=720, 1 ML	920-1320	920-1320	K4001-07-N03
	Middle lock L=820, 2 ML	1251-1430	1251-1430	K4001-08-N03
	Middle lock L=1130, 2 ML	—	1251-1730	K4001-11-N03
6a	Middle lock L=400, 1 MR + 1 ML	600-1000	600-1000	K4008-04-N03
	Middle lock L=650, 1 MR + 1 ML	850-1250	850-1250	K4008-06-N03
	Middle lock L=820, 1 MR + 1 ML	1251-1430	1251-1430	K4008-08-N03
	Middle lock L=1130, 1 MR + 2 ML	—	1251-1730	K4008-11-N03
7	Middle lock extension, 1 ML, 480 mm	—	1710-2210	K4005-05-N03
	Middle lock extension, 1 ML, 680 mm	—	2211-2390	K4005-07-N03
8	Bottom extension	—	450-800	K4009-00-N03
		—	801-2390	K4002-00-N03



## Tilt and turn set

## STRAIGHT CUT

## Hardware set combinations

Nº	Description	Application range by width	Application range by height	Part No.
9	Tilt locking plate, right	—	—	***
	Tilt locking plate, left	—	—	***
10	Locking plate	—	—	***
10a	Locking plate safety	—	—	***
10b	Tilt locking plate safety	—	—	***
11	Lifting plate	—	751-2390	***
12	Wrong operation safety device with sash lifter	—	751-2390	A7001-00-N03
13	Corner bearing	—	—	A5002-00-N03
13a	Corner bearing 6x22	—	—	A5004-00-N03
14	Drill-in corner hinge 3x5	—	—	A5003-00-N03
14a	Drill-in corner hinge with gasket pressure adjustment 6x12	—	—	A5007-00-N03
14b	Drill-in corner hinge with gasket pressure adjustment 6x16/26	—	—	A5006-00-N03
14c	Rebate corner hinge 20/9 left	—	—	A5009-09-L03
	Rebate corner hinge 20/9 right	—	—	A5009-09-R03
	Rebate corner hinge 20/13 left	—	—	A5009-13-L03
	Rebate corner hinge 20/13 right	—	—	A5009-13-R03
15	Stay arm bearing 3x3	—	—	A5001-00-N03
15a	Stay arm bearing 6x24	—	—	A5005-00-N03
16	Top sash hinge	—	—	K5001-**-N03
17	Cover of top sash hinge	—	—	A7004-10-N****
18	Cover of stay arm bearing	—	—	A7005-10-N****
19	Cover of the drill-in corner hinge	—	—	A7006-10-N****
19a	Cover of rebate corner hinge, left / right	—	—	A7009-00-L/R****
20	Top cover of corner bearing	—	—	A7008-10-N****
21	Bottom cover of corner bearing	—	—	A7007-10-N****
26	Extension lock 240 mm, 1 ML	—	—	K4003-02-N03
	Extension lock 480 mm, 1 ML	—	—	K4003-05-N03
27	Locking plate, integrated slit	—	—	***
28	Locking plate for adjustable integrated slit	—	—	***
29	Balcony catch	—	—	A7184-13-N03
29b	Balcony locking pin	—	—	A7207-00-N03
36	Extension lock for corner transmission 480 mm, 1 ML	—	—	K4010-00-N03
	Extension lock for corner transmission 680 mm, 1 ML	—	—	K4010-07-N03
	Extension lock for corner transmission 880 mm, 2 ML	—	—	K4010-09-N03
	Extension lock for corner transmission 480 mm, 1 MR	—	—	K4030-00-N03
38	Magnetic balcony catch, frame part	—	—	A7053-00-N03
38a	Magnetic balcony catch, sash part	—	—	A7055-**-N03

\* – displaced from the center

\*\* – according to displacement axis of sash groove (9 mm, 10 mm, 13 mm, 14 mm)

\*\*\* – look at the section "Profile-dependent elements"

\*\*\*\* – for decorative covers in other colors look at p. 27



Tilt and turn set "First Tilt"

Hardware set combinations

Tilt and turn set "First Tilt", straight cut

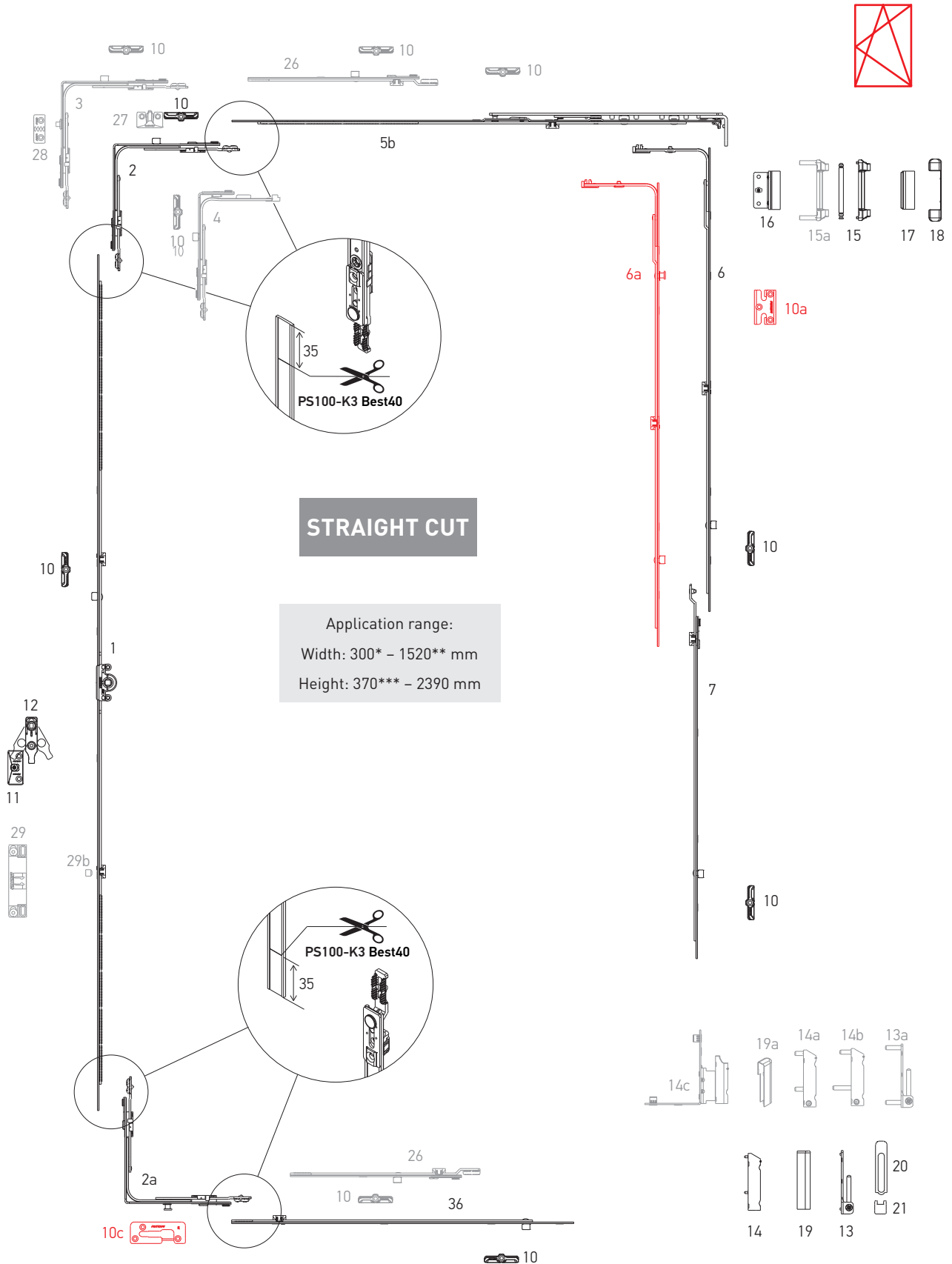

\* with narrow corner transmission  
 \*\* with the linear extension 240 mm  
 \*\*\*\*with the constant gear K1004-04-N03





## Tilt and turn set "First Tilt"

## STRAIGHT CUT

Hardware set combinations

Nº	Description	Application range by width	Application range by height	Part No.
1	Gear variable 0, L=320, 450-550	—	450-550	K1001-02-N03
	Gear variable 1, L=520, 551-750	—	551-750	K1001-04-N03
	Gear variable 2, L=1000, 751-1230, 1 ML	—	751-1230	K1001-09-N03
	Gear variable 3, L=1200, 950-1430, 1 ML	—	950-1430	K1001-11-N03
	Gear variable 4, L=1480, 1231-1710, 2 ML	—	1231-1710	K1001-14-N03
	Gear variable 5, L=1680, 1431-1910, 2 ML	—	1431-1910	K1001-16-N03
	Gear variable 6, L=2160, 1911-2390, 3 ML	—	1911-2390	K1001-21-N03
2	Corner transmission, 1 ML, 150×150	400-1280	450-2390	K2001-00-N03
2a	Corner transmission, 1 MR, 150×150	400-1280	450-2390	K2005-00-N03
3	Corner transmission, integrated slit, 1 ML, 150×150, left	400-1280	450-2390	K2004-00-L03
	Corner transmission, integrated slit, 1 ML, 150×150, right	400-1280	450-2390	K2004-00-R03
4	Narrow corner transmission, 1 ML, 50×150	300-400	450-2390	K2003-00-N03
		400-600	370-550*	
5b	Stay arm 1, "First Tilt", L=485, 400-600	400-600	—	K3014-05-N03
	Stay arm 2, "First Tilt", L=685, 601-800	601-800	—	K3014-07-N03
	Stay arm 3, "First Tilt", L=915, 801-1040, 1 ML	801-1040	—	K3014-09-N03
	Stay arm 4, "First Tilt", L=1165, 1041-1280, 1 ML	1041-1280	—	K3014-11-N03
6	Middle lock L=400, 1 ML	600-1000	600-1000	K4001-04-N03
	Middle lock L=650, 1 ML	850-1250	850-1250	K4001-06-N03
	Middle lock L=720, 1 ML	920-1320	920-1320	K4001-07-N03
	Middle lock L=820, 2 ML	1251-1430	1251-1430	K4001-08-N03
	Middle lock L=1130, 2 ML	—	1251-1730	K4001-11-N03
6a	Middle lock L=400, 1 MR + 1 ML	600-1000	600-1000	K4008-04-N03
	Middle lock L=650, 1 MR + 1 ML	850-1250	850-1250	K4008-06-N03
	Middle lock L=820, 1 MR + 1 ML	1251-1430	1251-1430	K4008-08-N03
	Middle lock L=1130, 1 MR + 2 ML	—	1251-1730	K4008-11-N03
7	Middle lock extension, 1 ML, 480 mm	—	850-1230	K4005-05-N03
	Middle lock extension, 1 ML, 680 mm	—	1231-1430	K4005-07-N03
10	Locking plate	—	—	***
10a	Locking plate safety	—	—	***
10C	Tilt locking plate "First Tilt", left / right	—	—	***
11	Lifting plate	—	—	***
12	Wrong operation safety device with sash lifter	—	751-2390	A7001-00-N03
13	Corner bearing 3×3	—	—	A5002-00-N03
13a	Corner bearing 6x22	—	—	A5004-00-N03
14	Drill-in corner hinge 3×5	—	—	A5003-00-N03
14a	Drill-in corner hinge with gasket pressure adjustment 6x12	—	—	A5007-00-N03
14b	Drill-in corner hinge with gasket pressure adjustment 6x16/26	—	—	A5006-00-N03
14C	Rebate corner hinge 20/9 left	—	—	A5009-09-L03
	Rebate corner hinge 20/9 right	—	—	A5009-09-R03
	Rebate corner hinge 20/13 left	—	—	A5009-13-L03
	Rebate corner hinge 20/13 right	—	—	A5009-13-R03

**Tilt and turn set “First Tilt”**

Hardware set combinations

**STRAIGHT CUT**

Nº	Description	Application range by width	Application range by height	Part No.
15	Stay arm bearing 3x3	—	—	A5001-00-N03
15a	Stay arm bearing 6x24	—	—	A5005-00-N03
16	Top sash hinge	—	—	K5001-**-N03
17	Cover of top sash hinge	—	—	A7004-10-N****
18	Cover of stay arm bearing	—	—	A7005-10-N****
19	Cover of the drill-in corner hinge	—	—	A7006-10-N****
19a	Cover of rebate corner hinge, left / right	—	—	A7009-00-L/R****
20	Top cover of corner bearing	—	—	A7008-10-N****
21	Bottom cover of corner bearing	—	—	A7007-10-N****
26	Extension lock 240 mm, 1 ML	—	—	K4003-02-N03
	Extension lock 480 mm, 1 ML	—	—	K4003-05-N03
27	Locking plate, integrated slit	—	—	***
28	Locking plate for adjustable integrated slit	—	—	***
36	Extension lock for corner transmission 480 mm, 1 ML	—	—	K4010-00-N03
	Extension lock for corner transmission 680 mm, 1 ML	—	—	K4010-07-N03
	Extension lock for corner transmission 880 mm, 2 ML	—	—	K4010-09-N03
	Extension lock for corner transmission 480 mm, 1 MR	—	—	K4030-00-N03

\* – displaced from the center

\*\* – according to displacement axis of sash groove (9 mm, 10 mm, 13 mm, 14 mm)

\*\*\* – look at the section “Profile-dependent elements”

\*\*\*\* – for decorative covers in other colors look at p. 27



**Turn set**

Hardware set combinations

Turn set, straight cut

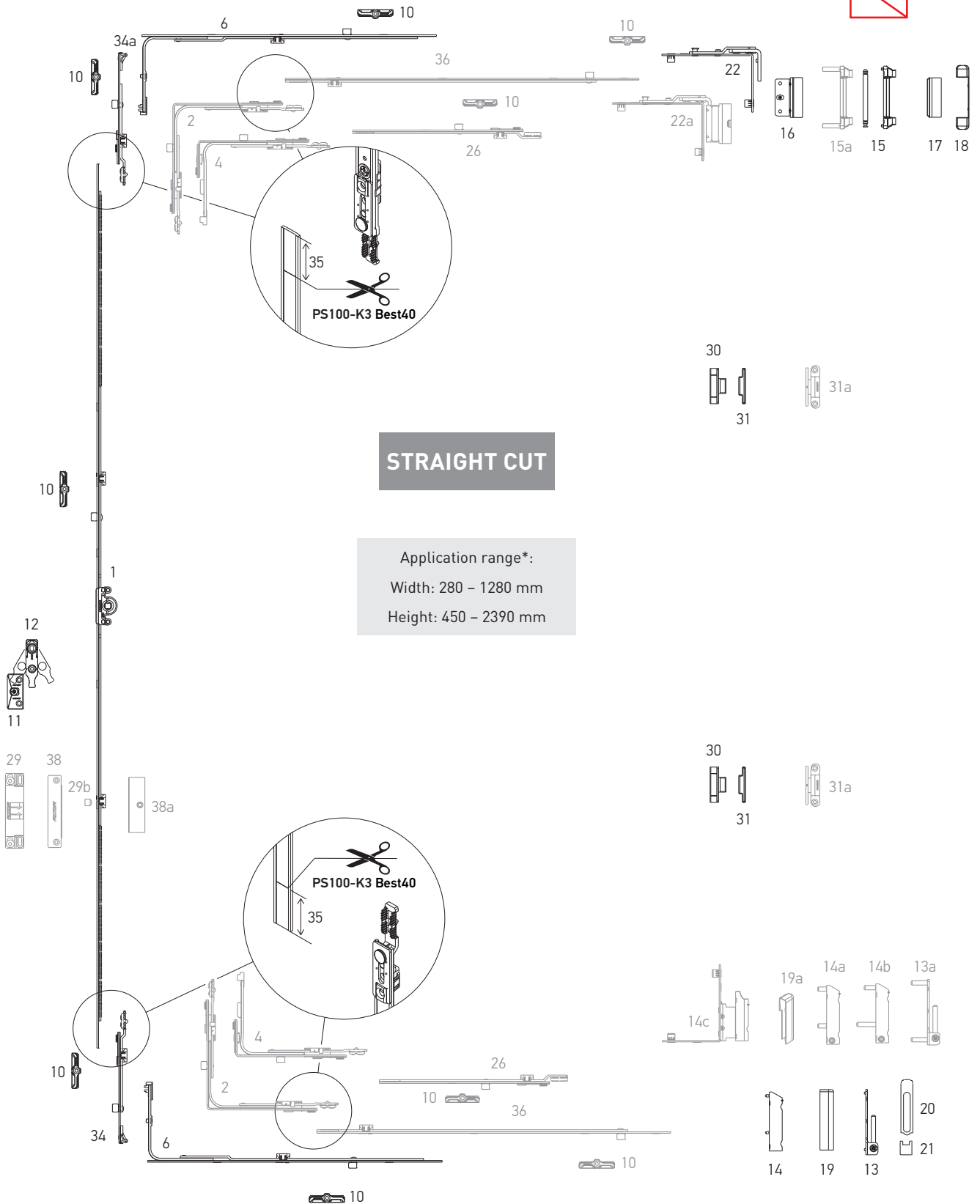
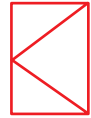

\* Use the shoot-bolt 34, 34a



## Turn set

## Hardware set combinations

**STRAIGHT CUT**

Nº	Description	Application range by width	Application range by height	Part No.
1	Gear variable 0, L=320, 450-550	—	450-550	K1001-02-N03
	Gear variable 1, L=520, 551-750	—	551-750	K1001-04-N03
	Gear variable 2, L=1000, 751-1230, 1 ML	—	751-1230	K1001-09-N03
	Gear variable 3, L=1200, 950-1430, 1 ML	—	950-1430	K1001-11-N03
	Gear variable 4, L=1480, 1231-1710, 2 ML	—	1231-1710	K1001-14-N03
	Gear variable 5, L=1680, 1431-1910, 2 ML	—	1431-1910	K1001-16-N03
	Gear variable 6, L=2160, 1911-2390, 3 ML	—	1911-2390	K1001-21-N03
2	Corner transmission, 1 ML, 150x150	330-1280	450-2390	K2001-00-N03
4	Narrow corner transmission, 1 ML, 50x150	280-1280	450-2390	K2003-00-N03
		330-520	290-350	
6	Middle lock L=400, 1 ML	600-1000	—	K4001-04-N03
	Middle lock L=650, 1 ML	850-1250	—	K4001-06-N03
10	Locking plate	—	—	***
11	Lifting plate	—	751-2390	***
12	Wrong operation safety device with sash lifter	—	751-2390	A7001-00-N03
13	Corner bearing 3x3	—	—	A5002-00-N03
13a	Corner bearing 6x22	—	—	A5004-00-N03
14	Drill-in corner hinge 3x5	—	—	A5003-00-N03
14a	Drill-in corner hinge with gasket pressure adjustment 6x12	—	—	A5007-00-N03
14b	Drill-in corner hinge with gasket pressure adjustment 6x16/26	—	—	A5006-00-N03
14C	Rebate corner hinge 20/9 left/right	—	—	A5009-09-L/R03
	Rebate corner hinge 20/13 left/right	—	—	A5009-13-L/R03
15	Stay arm bearing 3x3	—	—	A5001-00-N03
15a	Stay arm bearing 6x24	—	—	A5005-00-N03
16	Top sash hinge	—	—	K5001-**-N03
17	Cover of top sash hinge	—	—	A7004-10-N*
18	Cover of stay arm bearing	—	—	A7005-10-N*
19	Cover of the drill-in corner hinge	—	—	A7006-10-N*
19a	Cover of rebate corner hinge, left / right	—	—	A7009-00-L/R*
20	Top cover of corner bearing	—	—	A7008-10-N*
21	Bottom cover of corner bearing	—	—	A7007-10-N*
22	Turn stay arm	—	—	K5002-00-N03
22a	Turn stay arm 12/20-13 left/right	—	—	K5014-13-L/R03
	Turn stay arm 12/20-9 left/right	—	—	K5014-09-L/R03
	Turn stay arm 12/20-13 left/right	—	—	S5001-13-L03/R
	Turn stay arm 12/20-9 left/right	—	—	S5001-09-L03/R
26	Extension lock 240 mm, 1 ML	—	—	K4003-02-N03
	Extension lock 480 mm, 1 ML	—	—	K4003-05-N03
29	Balcony catch	—	—	A7184-13-N03
29b	Balcony locking pin	—	—	A7207-00-N03
30	Concealed middle hinge, sash part	—	—	A7056-00-N03
31	Concealed middle hinge, frame part	—	—	A7057-**-N03

**Turn set**

## Hardware set combinations

**STRAIGHT CUT**

Nº	Description	Application range by width	Application range by height	Part No.
31a	Middle hinge (white)	—	—	A7185-00-N01
	Middle hinge (brown)	—	—	A7185-00-N02
	Middle hinge (gray anthracite)	—	—	A7185-00-N09
34	Bottom extension for turn sash 90°	—	—	K4007-00-N03
34a	Bottom extension for turn sash 180°	—	—	K4011-00-N03
36	Extension lock for corner transmission 480 mm, 1 ML	—	—	K4010-00-N03
	Extension lock for corner transmission 680 mm, 1 ML	—	—	K4010-07-N03
	Extension lock for corner transmission 880 mm, 2 ML	—	—	K4010-09-N03
	Extension lock for corner transmission 480 mm, 1 MR	—	—	K4030-00-N03
38	Magnetic balcony catch, frame part	—	—	A7053-00-N03
38a	Magnetic balcony catch, sash part	—	—	A7055-**-N03

\* – for decorative covers in other colors look at p. 27

\*\* – according to displacement axis of sash groove (9 mm, 10 mm, 13 mm, 14 mm)

\*\*\* – look at the section "Profile-dependent elements"



Turn set

Hardware set combinations

Turn set

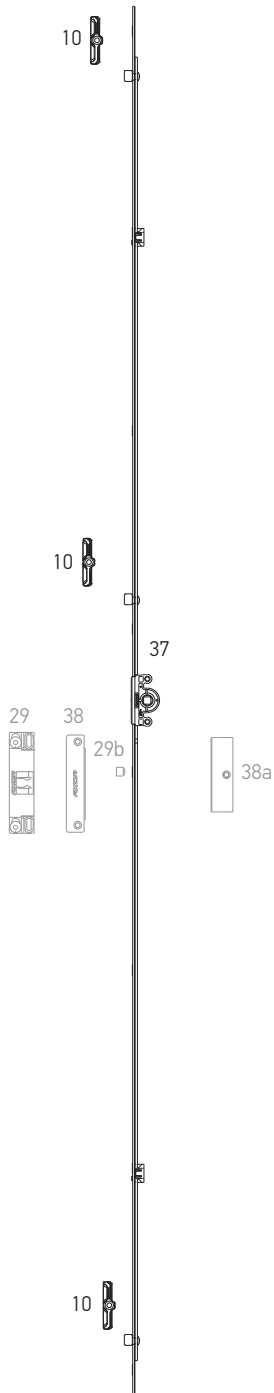

**STRAIGHT CUT**

Application range:  
Width: 280 – 700 mm  
Height: 300 – 2400 mm

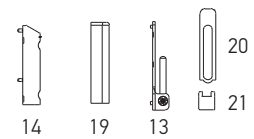
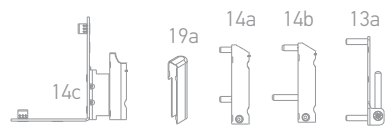
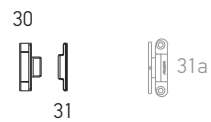
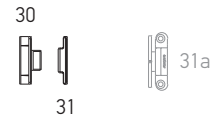
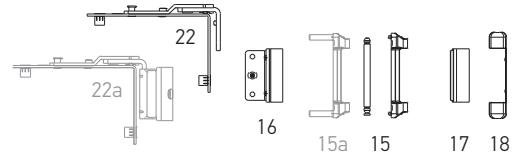



## Turn set

## STRAIGHT CUT

## Hardware set combinations

Nº	Description	Application range by width	Application range by height	Part No.
10	Locking plate	—	—	***
13	Corner bearing 3x3	—	—	A5002-00-N03
13a	Corner bearing 6x22	—	—	A5004-00-N03
14	Drill-in corner hinge 3x5	—	—	A5003-00-N03
14a	Drill-in corner hinge with gasket pressure adjustment 6x12	—	—	A5007-00-N03
14b	Drill-in corner hinge with gasket pressure adjustment 6x12/26	—	—	A5006-00-N03
14C	Rebate corner hinge 20/9 left	—	—	A5009-09-L03
	Rebate corner hinge 20/9 right	—	—	A5009-09-R03
	Rebate corner hinge 20/13 left	—	—	A5009-13-L03
	Rebate corner hinge 20/13 right	—	—	A5009-13-R03
15	Stay arm bearing 3x3	—	—	A5001-00-N03
15a	Stay arm bearing 6x24	—	—	A5005-00-N03
16	Top sash hinge	—	—	K5001-**-N03
17	Cover of top sash hinge	—	—	A7004-10-N*
18	Cover of stay arm bearing	—	—	A7005-10-N*
19	Cover of the drill-in corner hinge	—	—	A7006-10-N*
19a	Cover of rebate corner hinge, left / right	—	—	A7009-00-L/R*
20	Top cover of corner bearing	—	—	A7008-10-N*
21	Bottom cover of corner bearing	—	—	A7007-10-N*
22	Turn stay arm	—	—	K5002-00-N03
22a	Turn stay arm 12/20-13 left/right	—	—	K5014-13-L/R03
	Turn stay arm 12/20-9 left/right	—	—	K5014-09-L/R03
	Turn stay arm 12/20-13 left/right	—	—	S5001-13-L03/R
	Turn stay arm 12/20-9 left/right	—	—	S5001-09-L03/R
29	Balcony catch	—	—	A7184-13-N03
29b	Balcony locking pin	—	—	A7207-00-N03
30	Concealed middle hinge, sash part	—	—	A7056-00-N03
31	Concealed middle hinge, frame part	—	—	A7057-**-N03
31a	Middle hinge (white)	—	—	A7185-00-N01
	Middle hinge (brown)	—	—	A7185-00-N02
	Middle hinge (gray anthracite)	—	—	A7185-00-N09
37	Gear variable 1 L=300, 300 - 500, 2 ML	280-700	300-500	K1003-03-N03
	Gear variable 2 L=400, 401 - 600, 2 ML		401-600	K1003-04-N03
	Gear variable 3 L=600, 601 - 800, 2 ML		601-800	K1003-06-N03
	Gear variable 4 L=800, 801 - 1000, 2 ML		801-1000	K1003-08-N03
	Gear variable 5 L=1000, 1001 - 1200, 3 ML		1001-1200	K1003-10-N03
	Gear variable 6 L=1200, 1201 - 1400, 3 ML		1201-1400	K1003-12-N03
	Gear variable 7 L=1400, 1401 - 1600, 3 ML		1401-1600	K1003-14-N03
	Gear variable 8 L=1600, 1601 - 1800, 4ML		1601-1800	K1003-16-N03
	Gear variable 9 L=1800, 1801 - 2000, 4ML		1801-2000	K1003-18-N03
	Gear variable 10 L=2000, 2001 - 2200, 4ML		2001-2200	K1003-20-N03
Gear variable 11 L=2200, 2201 - 2400, 4ML	2201-2400	K1003-22-N03		
38	Magnetic balcony catch, frame part	—	—	A7053-00-N03
38a	Magnetic balcony catch, sash part	—	—	A7055-**-N03

\* – for decorative covers in other colors look at p. 27

\*\* – according to displacement axis of sash groove (9 mm, 10 mm, 13 mm, 14 mm)

\*\*\* – look at the section "Profile-dependent elements"



**Tilt set**

Hardware set combinations

Tilt set, straight cut.

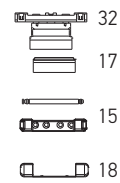
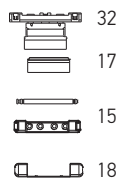
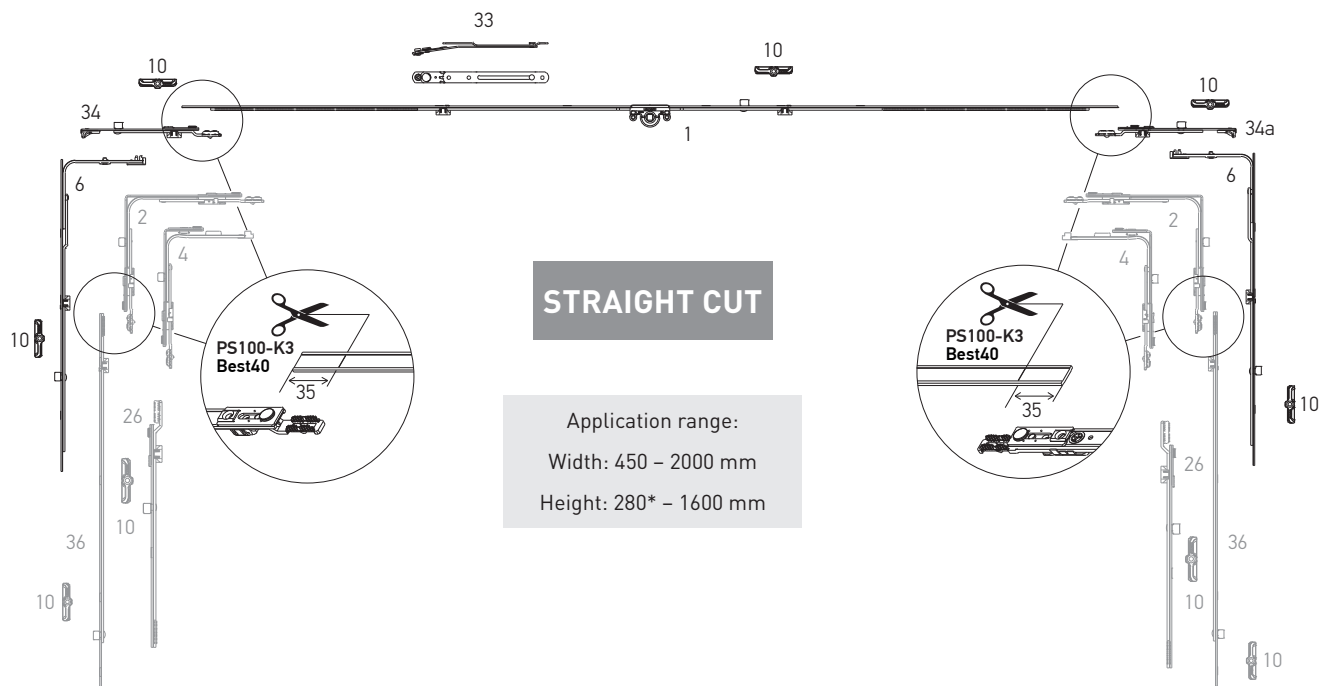
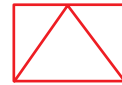

\* without middle lock





## Tilt set

## Hardware set combinations

**STRAIGHT CUT**

Nº	Description	Application range by width	Application range by height	Part No.
1	Gear variable 0, L=320, 450-550	—	450-550	K1001-02-N03
	Gear variable 1, L=520, 551-750	—	551-750	K1001-04-N03
	Gear variable 2, L=1000, 751-1230, 1 ML	—	751-1230	K1001-09-N03
	Gear variable 3, L=1200, 950-1430, 1 ML	—	950-1430	K1001-11-N03
	Gear variable 4, L=1480, 1231-1710, 2 ML	—	1231-1710	K1001-14-N03
	Gear variable 5, L=1680, 1431-1910, 2 ML	—	1431-1910	K1001-16-N03
	Gear variable 6, L=2160, 1911-2390, 3 ML	—	1911-2390	K1001-21-N03
2	Corner transmission, 1 ML, 150×150	330-1280	450-2390	K2001-00-N03
4	Narrow corner transmission, 1 ML, 50×150	280-1280	450-2390	K2003-00-N03
		330-520	290-350	
6	Middle lock L=400, 1 ML	—	600-1000	K4001-04-N03
	Middle lock L=650, 1 ML	—	850-1250	K4001-06-N03
	Middle lock L=720, 1 ML	—	920-1320	K4001-07-N03
	Middle lock L=820, 1 ML	—	1251-1430	K4001-08-N03
	Middle lock L=1130, 2 ML	—	1251-1730	K4001-11-N03
10	Locking plate	—	—	***
15	Stay arm bearing 3x3	—	—	A5001-00-N03
17	Cover of top sash hinge	—	—	A7004-10-N*
18	Cover of stay arm bearing	—	—	A7005-10-N*
26	Extension lock 240 mm, 1 ML	—	—	K4003-02-N03
	Extension lock 480 mm, 1 ML	—	—	K4003-05-N03
30	Concealed middle hinge, sash part	—	—	A7056-00-N03
31	Concealed middle hinge, frame part	—	—	A7057-**-N03
31a	Middle hinge (white)	—	—	A7185-00-N01
	Middle hinge (brown)	—	—	A7185-00-N02
	Middle hinge (gray anthracite)	—	—	A7185-00-N09
32	Bottom hinges for tilt sash	—	—	A7014-**-N03
33	Tilt stay arm	—	—	A7107-00-N03
	Tilt stay arm	—	—	A7017-00-N03
34	Bottom extension for turn sash 90°	—	—	K4007-00-N03
34a	Bottom extension for turn sash 180°	—	—	K4011-00-N03
36	Extension lock for corner transmission 480 mm, 1 ML	—	—	K4010-00-N03
	Extension lock for corner transmission 680 mm, 1 ML	—	—	K4010-07-N03
	Extension lock for corner transmission 880 mm, 2 ML	—	—	K4010-09-N03
	Extension lock for corner transmission 480 mm, 1 MR	—	—	K4030-00-N03

\* – for decorative covers in other colors look at p. 27

\*\* – according to displacement axis of sash groove (9 mm, 10 mm, 13 mm, 14 mm)

\*\*\* – look at the section "Profile-dependent elements"



**Tilt set**

Hardware set combinations

Tilt set

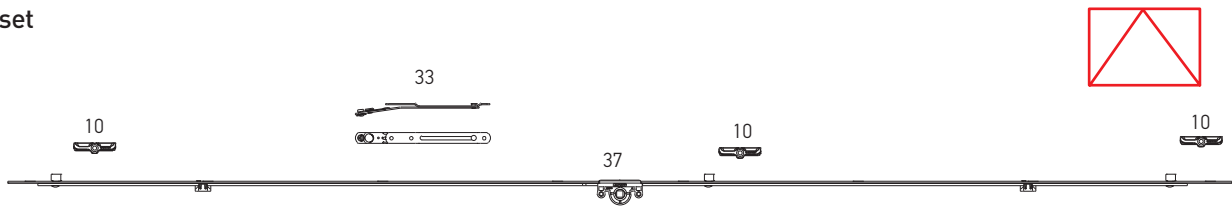

**STRAIGHT CUT**

Application range:  
Width: 300 – 2000 mm  
Height: 280 – 700 mm

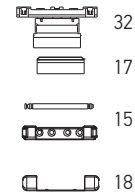
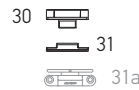
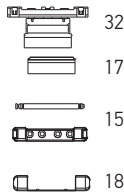

Nº	Description	Application range by width	Application range by height	Part No.
10	Locking plate	—	—	***
15	Stay arm bearing 3x3	—	—	A5001-00-N03
17	Cover of top sash hinge	—	—	A7004-10-N*
18	Cover of stay arm bearing	—	—	A7005-10-N*
30	Concealed middle hinge, sash part	—	—	A7056-00-N03
31	Concealed middle hinge, frame part	—	—	A7057-**-N03
31a	Middle hinge (white)	—	—	A7185-00-N01
	Middle hinge (brown)	—	—	A7185-00-N02
	Middle hinge (gray anthracite)	—	—	A7185-00-N09
32	Bottom hinges for tilt sash	—	—	A7014-**-N03
33	Tilt stay arm	—	—	A7107-00-N03
	Tilt stay arm	—	—	A7017-00-N03
37	Gear variable 1 L=300, 300 - 500, 2 ML	300-500	280-700	K1003-03-N03
	Gear variable 2 L=400, 401 - 600, 2 ML	401-600		K1003-04-N03
	Gear variable 3 L=600, 601 - 800, 2 ML	601-800		K1003-06-N03
	Gear variable 4 L=800, 801 - 1000, 2 ML	801-1000		K1003-08-N03
	Gear variable 5 L=1000, 1001 - 1200, 3 ML	1001-1200		K1003-10-N03
	Gear variable 6 L=1200, 1201 - 1400, 3 ML	1201-1400		K1003-12-N03
	Gear variable 7 L=1400, 1401 - 1600, 3 ML	1401-1600		K1003-14-N03
	Gear variable 8 L=1600, 1601 - 1800, 4ML	1601-1800		K1003-16-N03
Gear variable 9 L=1800, 1801 - 2000, 4ML	1801-2000	K1003-18-N03		

\* – for decorative covers in other colors look at p. 27

\*\* – according to displacement axis of sash groove (9 mm, 10 mm, 13 mm, 14 mm)

\*\*\* – look at the section "Profile-dependent elements"



**Double sash set, straight cut**

Hardware set combinations

Secondary sash of double-sash window

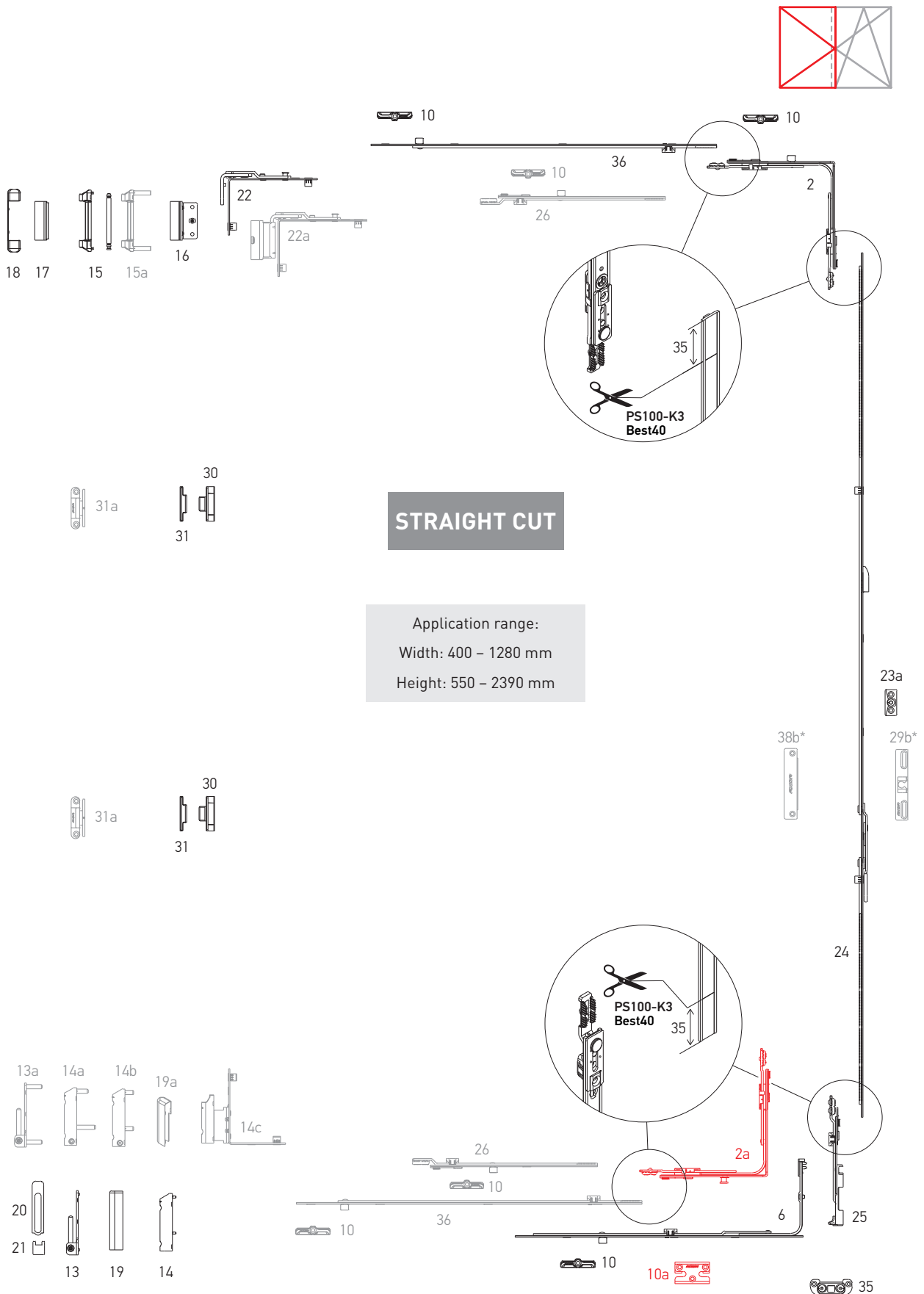



**Double sash set, straight cut**

Hardware set combinations

Main sash

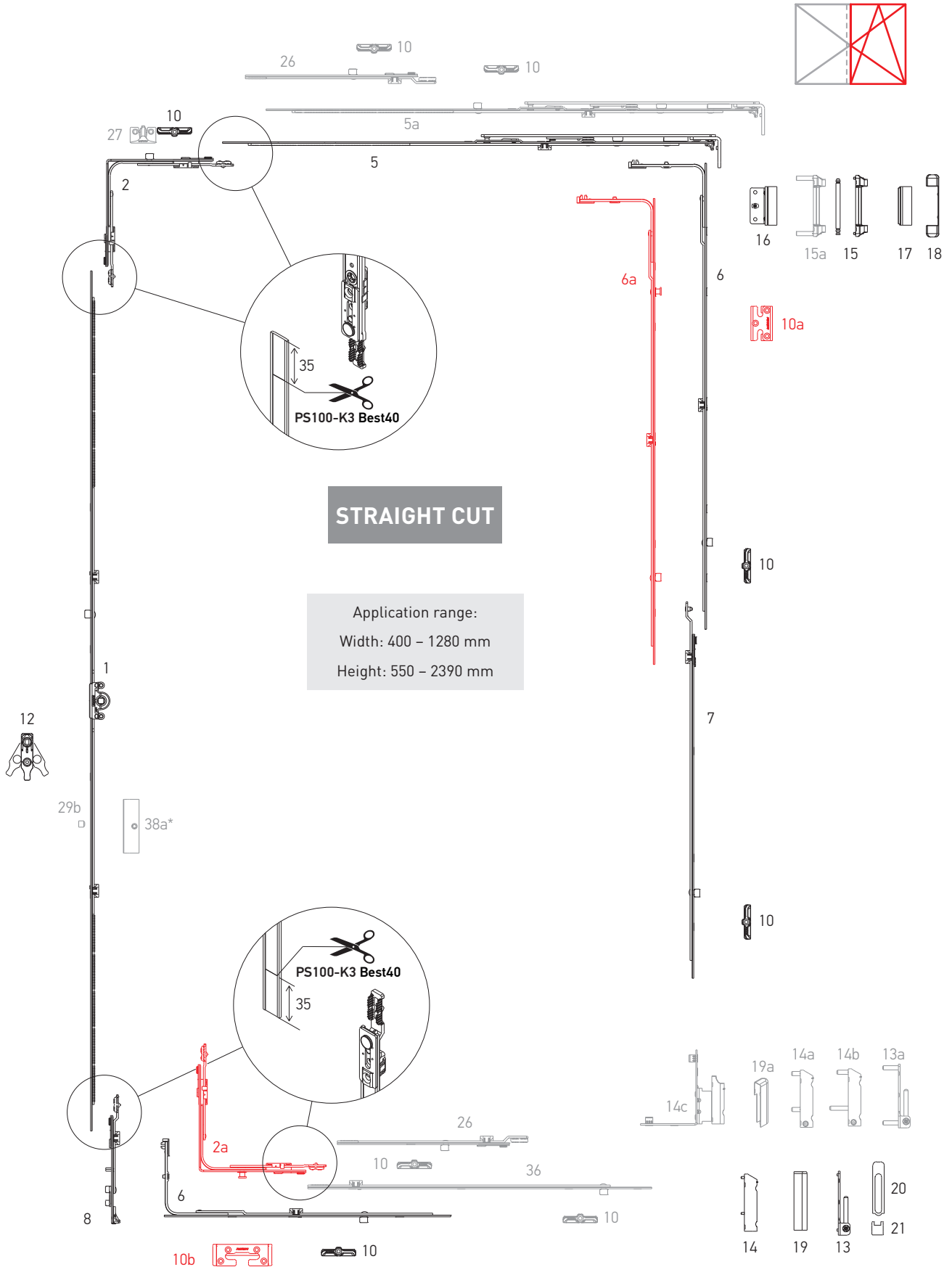



## Double sash set

## STRAIGHT CUT

## Hardware set combinations

Nº	Description	Application range by width	Application range by height	Part No.
1	Gear variable 1, L=520, 551-750	—	551-750	K1001-04-N03
	Gear variable 2, L=1000, 751-1230, 1 ML	—	751-1230	K1001-09-N03
	Gear variable 3, L=1200, 950-1430, 1 ML	—	950-1430	K1001-11-N03
	Gear variable 5, L=1680, 1431-1910, 2 ML	—	1431-1910	K1001-16-N03
	Gear variable 6, L=2160, 1911-2390, 3 ML	—	1911-2390	K1001-21-N03
2	Corner transmission, 1 ML, 150×150	400-1280	450-2390	K2001-00-N03
2a	Corner transmission, 1 MR, 150×150	400-1280	450-2390	K2005-00-N03
5	Stay arm 1, L=485, 400-600	400-600	—	K3001-05-N03
	Stay arm 2, L=685, 601-800	601-800	—	K3001-07-N03
	Stay arm 3, L=925, 801-1040, 1 ML	801-1040	—	K3001-09-N03
	Stay arm 4, L=1165, 1041-1280, 1 ML	1041-1280	—	K3001-11-N03
5a	Stay arm 2, L=685, 601-800, 1 ML	601-800	—	K3001-57-N03
6	Middle lock L=400, 1 ML	600-1000	600-1000	K4001-04-N03
	Middle lock L=650, 1 ML	850-1250	850-1250	K4001-06-N03
	Middle lock L=720, 1 ML	920-1320	920-1320	K4001-07-N03
	Middle lock L=820, 1 ML	1251-1430	1251-1430	K4001-08-N03
	Middle lock L=1130, 2 ML	—	1251-1730	K4001-11-N03
6a	Middle lock L=400, 1 MR + 1 ML	600-1000	600-1000	K4008-04-N03
	Middle lock L=650, 1 MR + 1 ML	850-1250	850-1250	K4008-06-N03
	Middle lock L=820, 1 MR + 1 ML	1251-1430	1251-1430	K4008-08-N03
	Middle lock L=1130, 1 MR + 2 ML	—	1251-1730	K4008-11-N03
7	Middle lock extension, 1 ML, 480 mm	—	1710-2210	K4005-05-N03
	Middle lock extension, 1 ML, 680 mm	—	2231-2390	K4005-07-N03
8	Bottom extension	—	450-800	K4009-00-N03
		—	801-2390	K4002-00-N03
10	Locking plate	—	—	***
10a	Locking plate safety	—	—	***
10b	Tilt locking plate safety	—	—	***
12	Wrong operation safety device with sash lifter	—	751-2390	A7001-00-N03
13	Corner bearing 3x3	—	—	A5002-00-N03
13a	Corner bearing 6x22	—	—	A5004-00-N03
14	Drill-in corner hinge 3x5	—	—	A5003-00-N03
14a	Drill-in corner hinge with gasket pressure adjustment 6×12	—	—	A5006-00-N03
14b	Drill-in corner hinge with gasket pressure adjustment 6×16/26	—	—	A5007-00-N03
14C	Rebate corner hinge 20/9 left	—	—	A5009-09-L03
	Rebate corner hinge 20/9 right	—	—	A5009-09-R03
	Rebate corner hinge 20/13 left	—	—	A5009-13-L03
	Rebate corner hinge 20/13 right	—	—	A5009-13-R03
15	Stay arm bearing 3x3	—	—	A5001-00-N03
15a	Stay arm bearing 6x24	—	—	A5005-00-N03
16	Top sash hinge	—	—	K5001-**-N03
17	Cover of top sash hinge	—	—	A7004-10-N*



## Double sash set

Hardware set combinations

**STRAIGHT CUT**

Nº	Description	Application range by width	Application range by height	Part No.
18	Cover of stay arm bearing	—	—	A7005-10-N*
19	Cover of the drill-in corner hinge	—	—	A7006-10-N*
19a	Cover of rebate corner hinge, left / right	—	—	A7009-00-L/R*
20	Top cover of corner bearing	—	—	A7008-10-N*
21	Bottom cover of corner bearing	—	—	A7007-10-N*
22	Turn stay arm	—	—	K5002-00-N03
22a	Turn stay arm 12/20-13 left/right	—	—	K5014-13-L/R03
	Turn stay arm 12/20-9 left/right	—	—	K5014-09-L/R03
	Turn stay arm 12/20-13 left/right	—	—	S5001-13-L03/R
	Turn stay arm 12/20-9 left/right	—	—	S5001-09-L03/R
23a	Lifting plate plate for double-sash window	—	—	A6001-00-N03
24	Double-sash gear 1 L=520, 551-750	—	551-750	K1002-04-N03
	Double-sash gear 2 L=720, 751-950	—	751-950	K1002-06-N03
	Double-sash gear 3 L=1200, 951-1430	—	951-1430	K1002-11-N03
	Double-sash gear 4 L=1680, 1431-1910	—	1431-1910	K1002-16-N03
	Double-sash gear 5 L=2160, 1911-2390	—	1911-2390	K1002-21-N03
25	Shoot bolt (bottom)	—	—	K4006-00-N03
26	Extension lock 240 mm, 1 ML	—	—	K4003-02-N03
	Extension lock 480 mm, 1 ML	—	—	K4003-05-N03
27	Locking plate, integrated slit	—	—	***
29a	Balcony catch for double-sash gear	—	1911-2390	A7047-00-N03
29b	Balcony locking pin	—	—	A7207-00-N03
30	Concealed middle hinge, sash part	—	—	A7056-00-N03
31	Concealed middle hinge, frame part	—	—	A7057-**-N03
31a	Middle hinge (white)	—	—	A7185-00-N01
	Middle hinge (brown)	—	—	A7185-00-N02
	Middle hinge (gray anthracite)	—	—	A7185-00-N09
35	Locking plate adjustable for shoot bolt	—	—	***
36	Extension lock for corner transmission 480 mm, 1 ML	—	—	K4010-00-N03
	Extension lock for corner transmission 680 mm, 1 ML	—	—	K4010-07-N03
	Extension lock for corner transmission 880 mm, 2 ML	—	—	K4010-09-N03
	Extension lock for corner transmission 480 mm, 1 MR	—	—	K4030-00-N03
38a	Magnetic balcony catch, sash part	—	—	A7055-**-N03
38b	Magnetic balcony catch for double-sash gear, frame part	—	—	A7054-00-N03

\* – for decorative covers in other colors look at p. 27

\*\* – according to displacement axis of sash groove (9 mm, 10 mm, 13 mm, 14 mm)

\*\*\* – look at the section "Profile-depending elements"

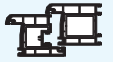

Double sash set "First Tilt", straight cut

Hardware set combinations

Secondary sash of double-sash window "First Tilt"

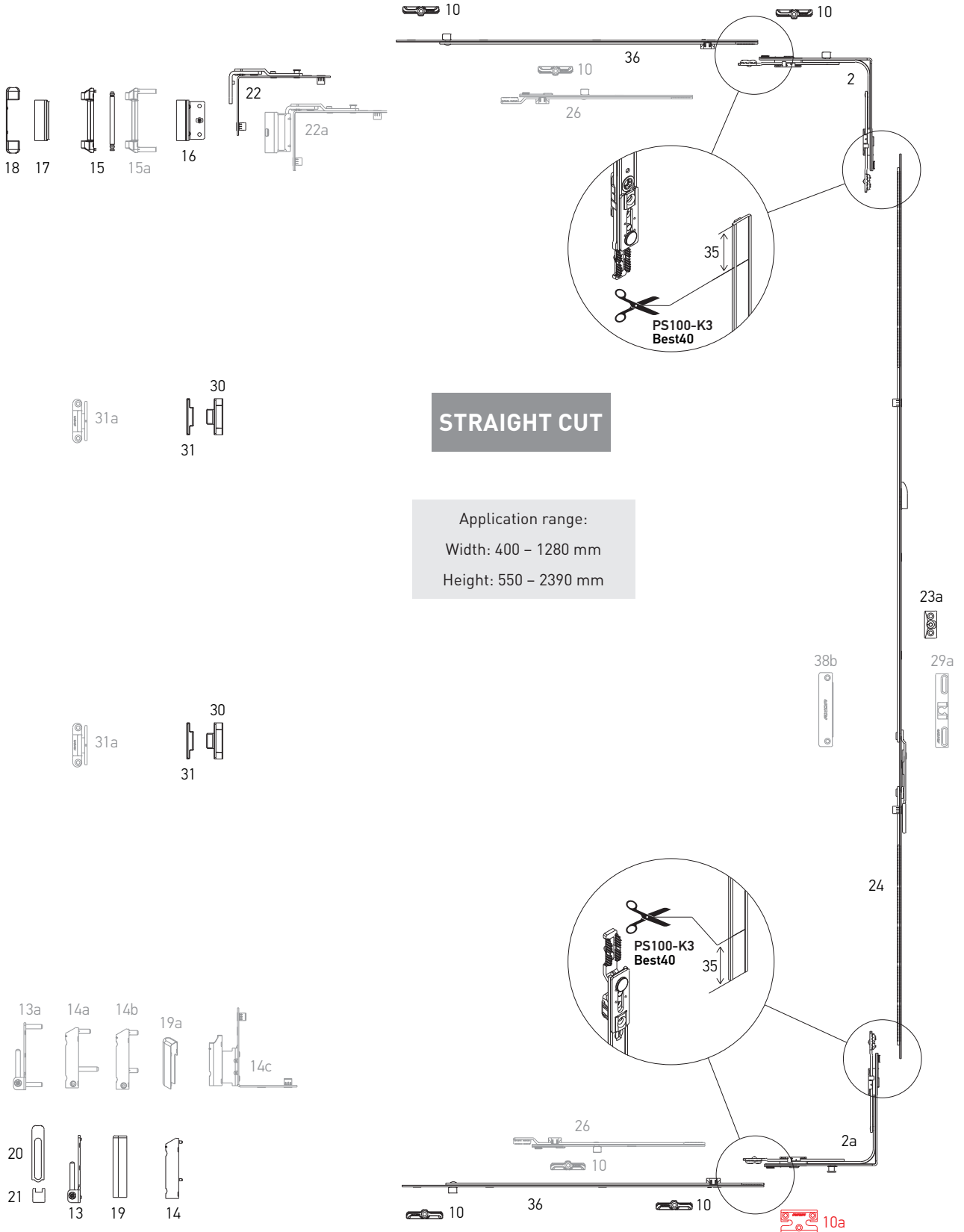
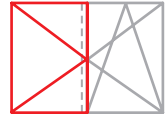

**STRAIGHT CUT**

Application range:  
Width: 400 - 1280 mm  
Height: 550 - 2390 mm



Double sash set "First Tilt", straight cut

Hardware set combinations

Main sash "First Tilt"

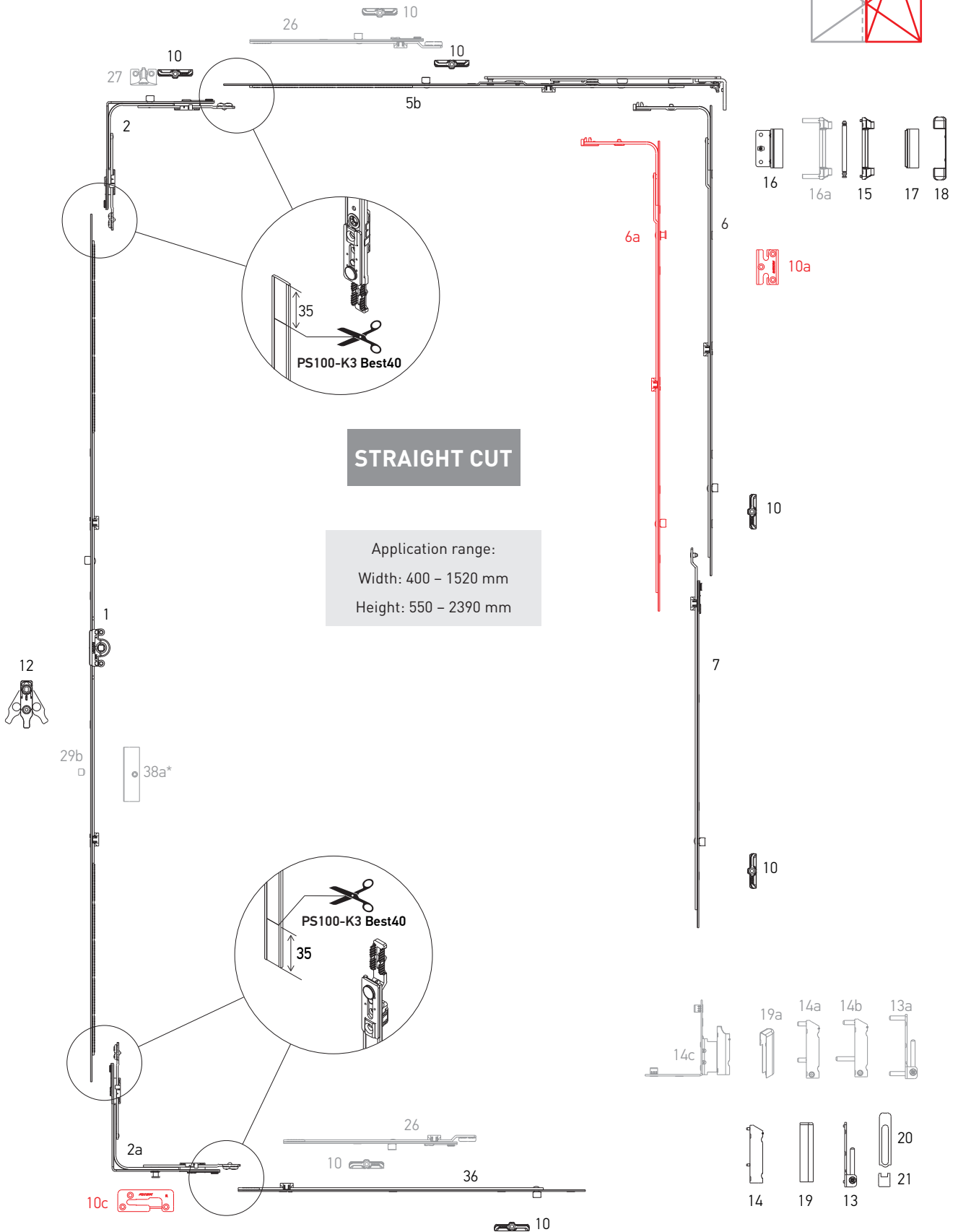
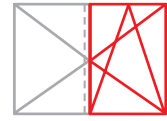

**STRAIGHT CUT**

Application range:  
Width: 400 - 1520 mm  
Height: 550 - 2390 mm

\* - only with gear K1002-21-N03





## Double sash set "First Tilt"

## STRAIGHT CUT

Hardware set combinations

Nº	Description	Application range by width	Application range by height	Part No.
1	Gear variable 1, L=520, 551-750	—	551-750	K1001-04-N03
	Gear variable 2, L=1000, 751-1230, 1 ML	—	751-1230	K1001-09-N03
	Gear variable 3, L=1200, 950-1430, 1 ML	—	950-1430	K1001-11-N03
	Gear variable 5, L=1680, 1431-1910, 2 ML	—	1431-1910	K1001-16-N03
	Gear variable 6, L=2160, 1911-2390, 3 ML	—	1911-2390	K1001-21-N03
2	Corner transmission, 1 ML, 150×150	400-1280	450-2390	K2001-00-N03
2a	Corner transmission, 1 MR, 150×150	400-1280	450-2390	K2005-00-N03
5b	Stay arm 1, "First Tilt", L=485, 400-600	400-600	—	K3014-05-N03
	Stay arm 2, "First Tilt", L=685, 601-800	601-800	—	K3014-07-N03
	Stay arm 3, "First Tilt", L=915, 801-1040, 1 ML	801-1040	—	K3014-09-N03
	Stay arm 4, "First Tilt", L=1165, 1041-1280, 1 ML	1041-1280	—	K3014-11-N03
6	Middle lock L=400, 1 ML	—	600-1000	K4001-04-N03
	Middle lock L=650, 1 ML	—	850-1250	K4001-06-N03
	Middle lock L=720, 1 ML	—	920-1320	K4001-07-N03
	Middle lock L=820, 2 ML	—	1251-1430	K4001-08-N03
	Middle lock L=1130, 2 ML	—	1251-1730	K4001-11-N03
6a	Middle lock L=400, 1 MR + 1 ML	—	600-1000	K4008-04-N03
	Middle lock L=650, 1 MR + 1 ML	—	850-1250	K4008-06-N03
	Middle lock L=820, 1 MR + 1 ML	—	1251-1430	K4008-08-N03
	Middle lock L=1130, 1 MR + 2 ML	—	1251-1730	K4008-11-N03
7	Middle lock extension, 1 ML, 480 mm	—	850-1230	K4005-05-N03
	Middle lock extension, 1 ML, 680 mm	—	1231-1430	K4005-07-N03
10	Locking plate	—	—	***
10a	Locking plate safety	—	—	***
10C	Tilt locking plate "First Tilt", left/right	—	—	***
12	Wrong operation safety device with sash lifter	—	751-2390	A7001-00-N03
13	Corner bearing 3×3	—	—	A5002-00-N03
13a	Corner bearing 6×22	—	—	A5004-00-N03
14	Drill-in corner hinge 3×5	—	—	A5003-00-N03
14a	Drill-in corner hinge with gasket pressure adjustment 6×12	—	—	A5006-00-N03
14b	Drill-in corner hinge with gasket pressure adjustment 6×16/26	—	—	A5007-00-N03
14C	Rebate corner hinge 20/9 left	—	—	A5009-09-L03
	Rebate corner hinge 20/9 right	—	—	A5009-09-R03
	Rebate corner hinge 20/13 left	—	—	A5009-13-L03
	Rebate corner hinge 20/13 right	—	—	A5009-13-R03
15	Stay arm bearing 3×3	—	—	A5001-00-N03
15a	Stay arm bearing 6×24	—	—	A5005-00-N03
16	Top sash hinge	—	—	***
17	Cover of top sash hinge	—	—	A7004-10-N*
18	Cover of stay arm bearing	—	—	A7005-10-N*

**Double sash set “First Tilt”**

Hardware set combinations

**STRAIGHT CUT**

Nº	Description	Application range by width	Application range by height	Part No.
19	Cover of the drill-in corner hinge	—	—	A7006-10-N*
19a	Cover of rebate corner hinge, left / right	—	—	A7009-00-L/R*
20	Top cover of corner bearing	—	—	A7008-10-N*
21	Bottom cover of corner bearing	—	—	A7007-10-N*
22	Turn stay arm	—	—	K5002-00-N03
22a	Turn stay arm 12/20-13 left/right	—	—	K5014-13-L/R03
	Turn stay arm 12/20-9 left/right	—	—	K5014-09-L/R03
	Turn stay arm 12/20-13 left/right	—	—	S5001-13-L03/R
	Turn stay arm 12/20-9 left/right	—	—	S5001-09-L03/R
23a	Lifting plate plate for double-sash window	—	—	***
24	Double-sash gear 1 L=520, 551-750	—	551-750	K1002-04-N03
	Double-sash gear 2 L=720, 751-950	—	751-950	K1002-06-N03
	Double-sash gear 3 L=1200, 951-1430	—	951-1430	K1002-11-N03
	Double-sash gear 4 L=1680, 1431-1910	—	1431-1910	K1002-16-N03
	Double-sash gear 5 L=2160, 1911-2390	—	1911-2390	K1002-21-N03
26	Extension lock 240 mm, 1 ML	—	—	K4003-02-N03
	Extension lock 480 mm, 1 ML	—	—	K4003-05-N03
27	Locking plate, integrated slit	—	—	***
29a	Balcony catch for double-sash gear	—	1911-2390	A7047-00-N03
29b	Balcony locking pin	—	—	A7207-00-N03
30	Concealed middle hinge, sash part	—	—	A7056-00-N03
31	Concealed middle hinge, frame part	—	—	A7057-**-N03
31a	Middle hinge (white)	—	—	A7185-00-N01
	Middle hinge (brown)	—	—	A7185-00-N02
	Middle hinge (gray anthracite)	—	—	A7185-00-N09
36	Extension lock for corner transmission 480 mm, 1 ML	—	—	K4010-00-N03
	Extension lock for corner transmission 680 mm, 1 ML	—	—	K4010-07-N03
	Extension lock for corner transmission 880 mm, 2 ML	—	—	K4010-09-N03
	Extension lock for corner transmission 480 mm, 1 MR	—	—	K4030-00-N03
38a	Magnetic balcony catch, sash part	—	—	A7055-**-N03
38b	Magnetic balcony catch for double-sash gear	—	—	A7054-13-N03

\* – for decorative covers in other colors look at p. 27

\*\* – according to displacement axis of sash groove (9 mm, 10 mm, 13 mm, 14 mm)

\*\*\* – look at the section “Profile-dependent elements”

**Tilt and turn set**

Hardware set combinations

Tilt and turn set, eccentric cut.

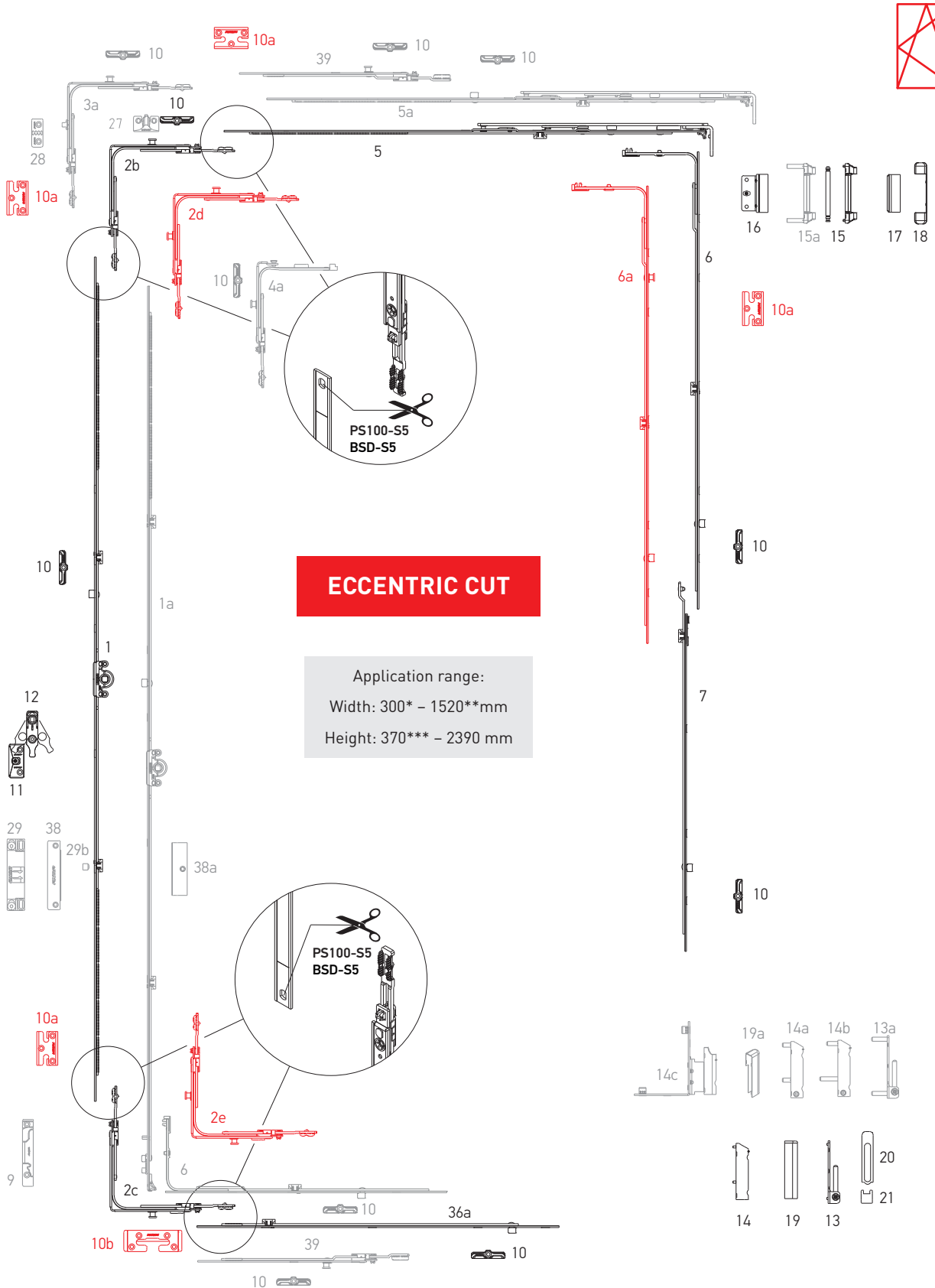

**ECCENTRIC CUT**

Application range:  
 Width: 300\* - 1520\*\*mm  
 Height: 370\*\*\* - 2390 mm

\* with narrow corner transmission  
 \*\* with the linear extension 240 mm  
 \*\*\* with the constant gear K1004-04-N03



## Tilt and turn set

**ECCENTRIC CUT**

## Hardware set combinations

Nº	Description	Application range by width	Application range by height	Part No.
1	Gear variable 0, L=320, 450-550	—	450-550	K1001-02-N03
	Gear variable 1, L=520, 551-750	—	551-750	K1001-04-N03
	Gear variable 2, L=1000, 751-1230, 1 ML	—	751-1230	K1001-09-N03
	Gear variable 3, L=1200, 950-1430, 1 ML	—	950-1430	K1001-11-N03
	Gear variable 4, L=1480, 1231-1710, 2 ML	—	1231-1710	K1001-14-N03
	Gear variable 5, L=1680, 1431-1910, 2 ML	—	1431-1910	K1001-16-N03
	Gear variable 6, L=2160, 1911-2390, 3 ML	—	1911-2390	K1001-21-N03
1a	Constant gear 0, L=435, G=140, 370-550*	—	370-550	K1004-04-N03
	Constant gear 1, L=385, G=175, 400-500*	—	400-500	K1004-03-N03
	Constant gear 2, L=565, G=200, 480-680*	—	480-680	K1004-05-N03
	Constant gear 3, L=805, G=300, 681-920*, 1 ML	—	681-920	K1004-08-N03
	Constant gear 4, L=1045, G=450, 921-1160*, 1 ML	—	921-1160	K1004-10-N03
	Constant gear 5, L=1285, G=600, 1161-1400*, 1 ML	—	1161-1400	K1004-12-N03
	Constant gear 6, L=1525, G=600, 1401-1640*, 2 ML	—	1401-1640	K1004-15-N03
	Constant gear 7, L=1765, G=600, 1641-1880*, 2 ML	—	1641-1880	K1004-17-N03
	Constant gear 8, L=1765, G=1000, 1641-1880*, 2 ML	—	1641-1880	K1004-18-N03
	Constant gear 9, L=2005, G=1000, 1881-2120*, 2 ML	—	1881-2120	K1004-20-N03
	Constant gear 10, L=2245, G=1000, 2121-2360*, 3 ML	—	2121-2360	K1004-22-N03
2b	Corner transmission, 1 MR, 115×115	400-1280	450-2390	K2025-00-N03
2c	Corner transmission, bottom, 1 MR, 115×115	400-1280	450-2390	K2028-00-N03
2d	Corner transmission, 2 MR, 115×115	400-1280	450-2390	K2032-00-N03
2e	Corner transmission, bottom, 2 MR, 115×115	400-1280	450-2390	K2029-00-N03
3a	Corner transmission, integrated slit, 1 MR, left/right, 115×115	400-1280	450-2390	K2034-00-L/R03
4a	Narrow corner transmission, 1 MR, 115×15	300-400	450-2390	K2026-00-N03
		400-600	370-550*	
5	Stay arm 1, L=485, 400-600	400-600	—	K3001-05-N03
	Stay arm 2, L=685, 601-800	601-800	—	K3001-07-N03
	Stay arm 3, L=925, 801-1040, 1 ML	801-1040	—	K3001-09-N03
	Stay arm 4, L=1165, 1041-1280, 1 ML	1041-1280	—	K3001-11-N03
5a	Stay arm 2, L=685, 601-800, 1 ML	601-800	—	K3001-57-N03
6	Middle lock L=400, 1 ML	600-1000	600-1000	K4001-04-N03
	Middle lock L=650, 1 ML	850-1250	850-1250	K4001-06-N03
	Middle lock L=720, 1 ML	920-1320	920-1320	K4001-07-N03
	Middle lock L=820, 2 ML	1251-1430	1251-1430	K4001-08-N03
	Middle lock L=1130, 2 ML	—	1251-1730	K4001-11-N03
6a	Middle lock L=400, 1 MR + 1 ML	600-1000	600-1000	K4008-04-N03
	Middle lock L=650, 1 MR + 1 ML	850-1250	850-1250	K4008-06-N03
	Middle lock L=820, 1 MR + 1 ML	1251-1430	1251-1430	K4008-08-N03
	Middle lock L=1130, 1 MR + 2 ML	—	1251-1730	K4008-11-N03
7	Middle lock extension, 1 ML, 480 mm	—	1710-2210	K4005-05-N03
	Middle lock extension, 1 ML, 680 mm	—	2211-2390	K4005-07-N03
9	Tilt locking plate, right / left	—	—	***



## Tilt and turn set

**ECCENTRIC CUT**

## Hardware set combinations

Nº	Description	Application range by width	Application range by height	Part No.
10	Locking plate	—	—	***
10a	Locking plate safety	—	—	***
10b	Tilt locking plate safety	—	—	***
11	Lifting plate	—	751-2390	***
12	Wrong operation safety device with sash lifter	—	751-2390	A7001-00-N03
13	Corner bearing 3x3	—	—	A5002-00-N03
13a	Corner bearing 6x22	—	—	A5004-00-N03
14	Drill-in corner hinge 3x5	—	—	A5003-00-N03
14a	Drill-in corner hinge with gasket pressure adjustment 6x12	—	—	A5007-00-N03
14b	Drill-in corner hinge with gasket pressure adjustment 6x16/26	—	—	A5006-00-N03
14c	Rebate corner hinge 20/9 left	—	—	A5009-09-L03
	Rebate corner hinge 20/9 right	—	—	A5009-09-R03
	Rebate corner hinge 20/13 left	—	—	A5009-13-L03
	Rebate corner hinge 20/13 right	—	—	A5009-13-R03
15	Stay arm bearing 3x3	—	—	A5001-00-N03
15a	Stay arm bearing 6x24	—	—	A5005-00-N03
16	Top sash hinge	—	—	K5001-**-N03
17	Cover of top sash hinge	—	—	A7004-10-N****
18	Cover of stay arm bearing	—	—	A7005-10-N****
19	Cover of the drill-in corner hinge	—	—	A7006-10-N****
19a	Cover of rebate corner hinge, left / right	—	—	A7009-00-L/R****
20	Top cover of corner bearing	—	—	A7008-10-N****
21	Bottom cover of corner bearing	—	—	A7007-10-N****
27	Locking plate, integrated slit	—	—	***
28	Locking plate for adjustable integrated slit	—	—	***
29	Balcony catch	—	—	A7184-13-N03
29b	Balcony locking pin	—	—	A7207-00-N03
36a	Extension lock 480 mm, 1 ML	—	—	K4053-05-N03
	Extension lock 680 mm, 1 ML	—	—	K4053-07-N03
	Extension lock 880 mm, 2 ML	—	—	K4053-09-N03
38	Magnetic balcony catch, frame part	—	—	A7053-00-N03
38a	Magnetic balcony catch, sash part	—	—	A7055-**-N03
39	Extension lock 240 mm, 1 MR	—	—	K4050-02-N03
	Extension lock 480 mm, 1 MR	—	—	K4050-05-N03

\* – displaced from the center

\*\* – according to displacement axis of sash groove (9 mm, 10 mm, 13 mm, 14 mm)

\*\*\* – look at the section "Profile-depending elements"

\*\*\*\* – for decorative covers in other colors look at p. 27



Tilt and turn set "First Tilt"

Hardware set combinations

Tilt and turn set "First Tilt", eccentric cut

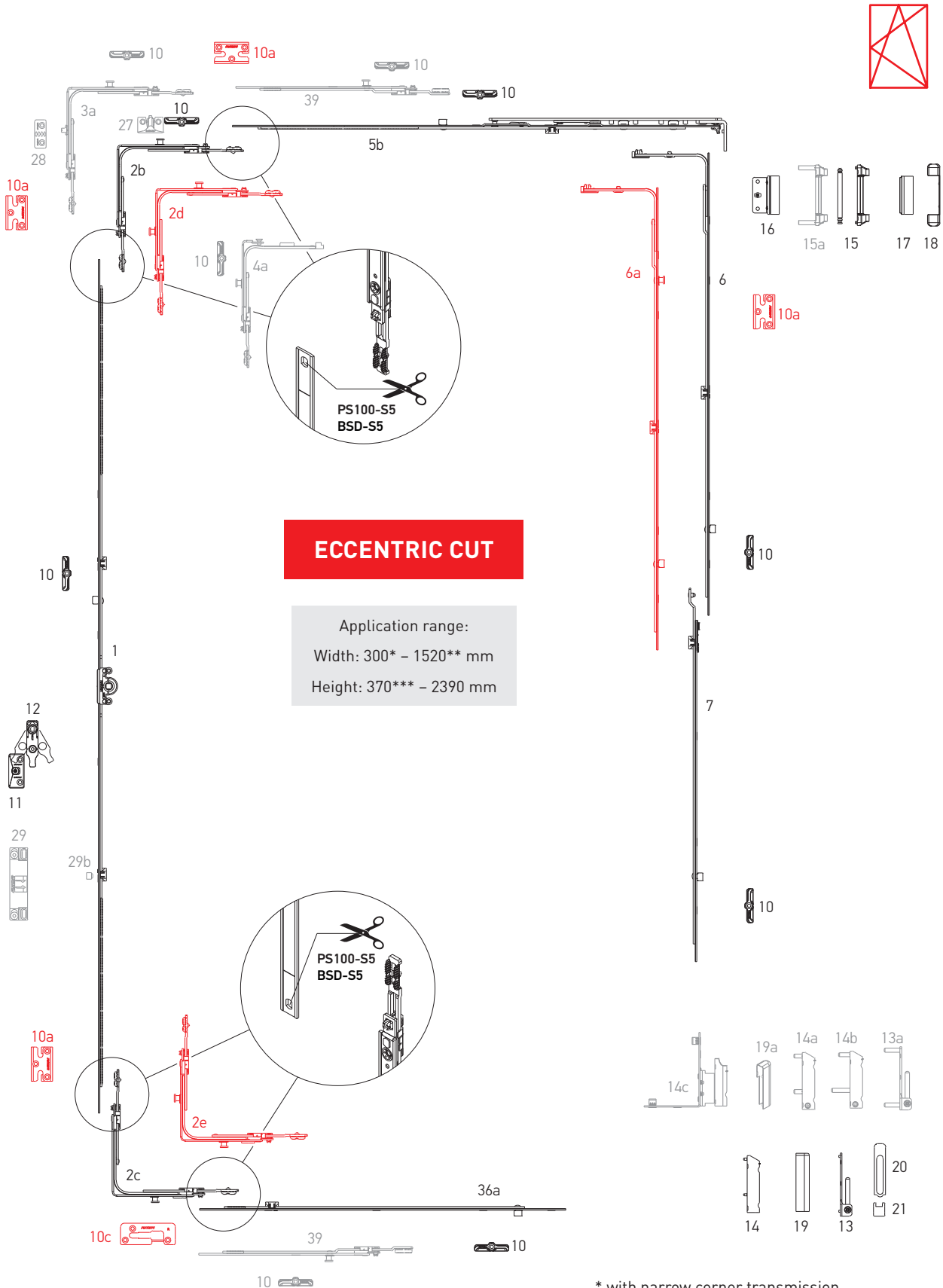

**ECCENTRIC CUT**

Application range:  
 Width: 300\* - 1520\*\* mm  
 Height: 370\*\*\* - 2390 mm

\* with narrow corner transmission  
 \*\* with the linear extension 240 mm  
 \*\*\* with the constant gear K1004-04-N03



## Tilt and turn set "First Tilt"

**ECCENTRIC CUT**

Hardware set combinations

Nº	Description	Application range by width	Application range by height	Part No.
1	Gear variable 0, L=320, 450-550	—	450-550	K1001-02-N03
	Gear variable 1, L=520, 551-750	—	551-750	K1001-04-N03
	Gear variable 2, L=1000, 751-1230, 1 ML	—	751-1230	K1001-09-N03
	Gear variable 3, L=1200, 950-1430, 1 ML	—	950-1430	K1001-11-N03
	Gear variable 4, L=1480, 1231-1710, 2 ML	—	1231-1710	K1001-14-N03
	Gear variable 5, L=1680, 1431-1910, 2 ML	—	1431-1910	K1001-16-N03
	Gear variable 6, L=2160, 1911-2390, 3 ML	—	1911-2390	K1001-21-N03
2b	Corner transmission, 1 MR, 115×115	400-1280	450-2390	K2025-00-N03
2c	Corner transmission, bottom, 1 MR, 115×115	400-1280	450-2390	K2028-00-N03
2d	Corner transmission, 2 MR, 115×115	400-1280	450-2390	K2032-00-N03
2e	Corner transmission, bottom, 2 MR, 115×115	400-1280	450-2390	K2029-00-N03
3a	Corner transmission, integrated slit, 1 MR, left/right, 115×115	400-1280	450-2390	K2034-00-L/R03
4a	Narrow corner transmission, 1 MR, 115×115	300-400	450-2390	K2026-00-N03
		400-600	370-550*	
5b	Stay arm 1, "First Tilt", L=485, 400-600	400-600	—	K3014-05-N03
	Stay arm 2, "First Tilt", L=685, 601-800	601-800	—	K3014-07-N03
	Stay arm 3, "First Tilt", L=915, 801-1040, 1 ML	801-1040	—	K3014-09-N03
	Stay arm 4, "First Tilt", L=1165, 1041-1280, 1 ML	1041-1280	—	K3014-11-N03
6	Middle lock L=400, 1 ML	600-1000	600-1000	K4001-04-N03
	Middle lock L=650, 1 ML	850-1250	850-1250	K4001-06-N03
	Middle lock L=720, 1 ML	920-1320	920-1320	K4001-07-N03
	Middle lock L=820, 2 ML	1251-1430	1251-1430	K4001-08-N03
	Middle lock L=1130, 2 ML	—	1251-1730	K4001-11-N03
6a	Middle lock L=400, 1 MR + 1 ML	600-1000	600-1000	K4008-04-N03
	Middle lock L=650, 1 MR + 1 ML	850-1250	850-1250	K4008-06-N03
	Middle lock L=820, 1 MR + 1 ML	1251-1430	1251-1430	K4008-08-N03
	Middle lock L=1130, 1 MR + 2 ML	—	1251-1730	K4008-11-N03
7	Middle lock extension, 1 ML, 480 mm	—	850-1230	K4005-05-N03
	Middle lock extension, 1 ML, 680 mm	—	1231-1430	K4005-07-N03
10	Locking plate	—	—	***
10a	Locking plate safety	—	—	***
10c	Tilt locking plate "First Tilt", left / right	—	—	***
11	Lifting plate	—	—	***
12	Wrong operation safety device with sash lifter	—	751-2390	A7001-00-N03
13	Corner bearing 3x3	—	—	A5002-00-N03
13a	Corner bearing 6x22	—	—	A5004-00-N03
14	Drill-in corner hinge 3x5	—	—	A5003-00-N03
14a	Drill-in corner hinge with gasket pressure adjustment 6x12	—	—	A5007-00-N03
14b	Drill-in corner hinge with gasket pressure adjustment 6x16/26	—	—	A5006-00-N03

**Tilt and turn set “First Tilt”**
**ECCENTRIC CUT**

Hardware set combinations

Nº	Description	Application range by width	Application range by height	Part No.
14C	Rebate corner hinge 20/9 left	—	—	A5009-09-L03
	Rebate corner hinge 20/9 right	—	—	A5009-09-R03
	Rebate corner hinge 20/13 left	—	—	A5009-13-L03
	Rebate corner hinge 20/13 right	—	—	A5009-13-R03
15	Stay arm bearing 3x3	—	—	A5001-00-N03
15a	Stay arm bearing 6x24	—	—	A5005-00-N03
16	Top sash hinge	—	—	K5001-**-N03
17	Cover of top sash hinge	—	—	A7004-10-N****
18	Cover of stay arm bearing	—	—	A7005-10-N****
19	Cover of the drill-in corner hinge	—	—	A7006-10-N****
19a	Cover of rebate corner hinge, left / right	—	—	A7009-00-L/R****
20	Top cover of corner bearing	—	—	A7008-10-N****
21	Bottom cover of corner bearing	—	—	A7007-10-N****
27	Locking plate, integrated slit	—	—	***
28	Locking plate for adjustable integrated slit	—	—	***
36a	Extension lock 480 mm, 1 ML	—	—	K4053-05-N03
	Extension lock 680 mm, 1 ML	—	—	K4053-07-N03
	Extension lock 880 mm, 2 ML	—	—	K4053-09-N03
39	Extension lock 240 mm, 1 MR	—	—	K4050-02-N03
	Extension lock 480 mm, 1 MR	—	—	K4050-05-N03

\* – displaced from the center

\*\* – according to displacement axis of sash groove (9 mm, 10 mm, 13 mm, 14 mm)

\*\*\* – look at the section “Profile-dependent elements”

\*\*\*\* – for decorative covers in other colors look at p. 27



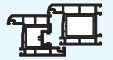

Turn set

Hardware set combinations

Turn set, eccentric cut

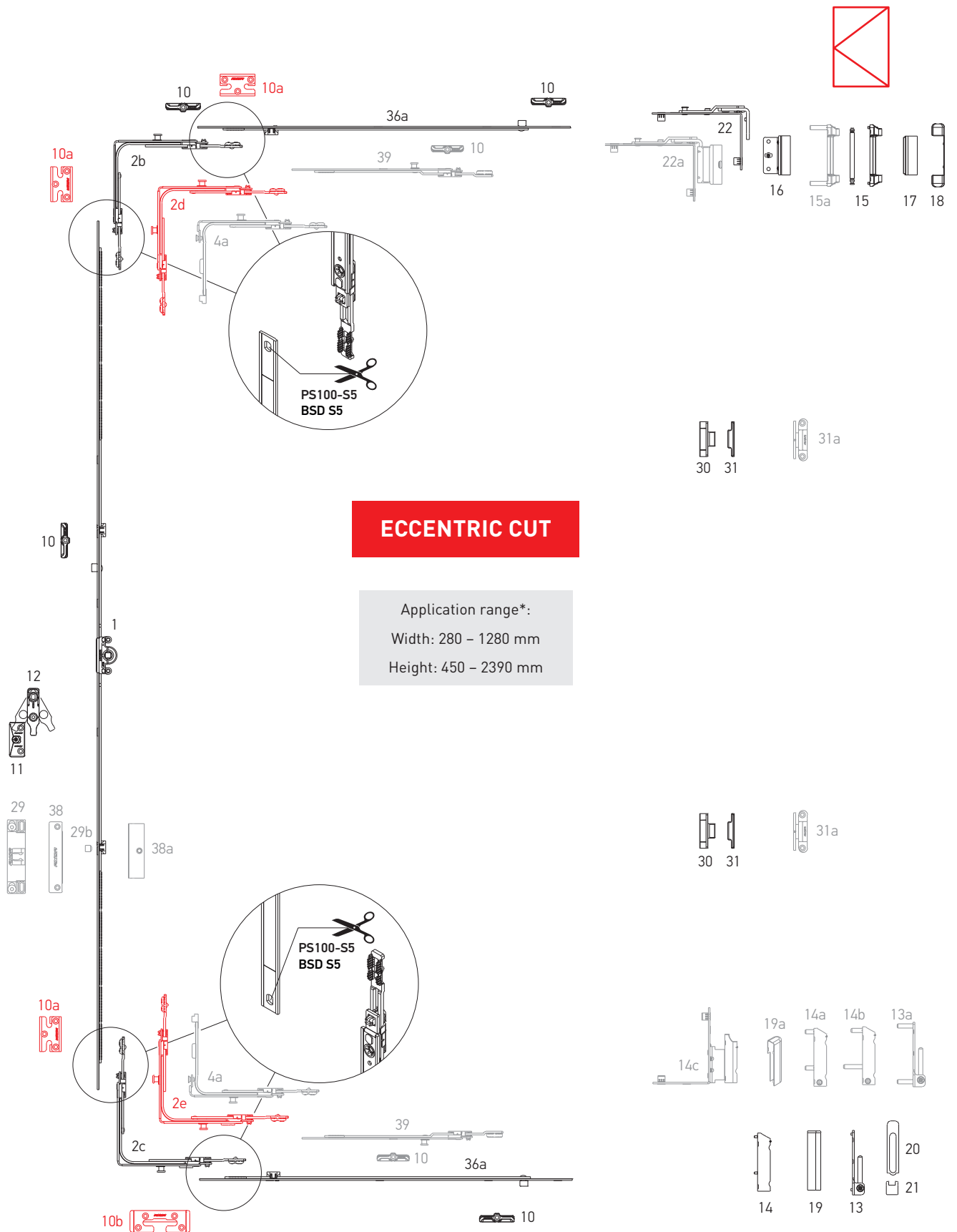

**ECCENTRIC CUT**

Application range\*:  
 Width: 280 - 1280 mm  
 Height: 450 - 2390 mm

\* Use the shoot-bolt 34, 34a



## Turn set

**ECCENTRIC CUT**

## Hardware set combinations

Nº	Description	Application range by width	Application range by height	Part No.
1	Gear variable 0, L=320, 450-550	—	450-550	K1001-02-N03
	Gear variable 1, L=520, 551-750	—	551-750	K1001-04-N03
	Gear variable 2, L=1000, 751-1230, 1 ML	—	751-1230	K1001-09-N03
	Gear variable 3, L=1200, 950-1430, 1 ML	—	950-1430	K1001-11-N03
	Gear variable 4, L=1480, 1231-1710, 2 ML	—	1231-1710	K1001-14-N03
	Gear variable 5, L=1680, 1431-1910, 2 ML	—	1431-1910	K1001-16-N03
	Gear variable 6, L=2160, 1911-2390, 3 ML	—	1911-2390	K1001-21-N03
2b	Corner transmission, 1 MR, 115×115	400-1280	450-2390	K2025-00-N03
2c	Corner transmission, bottom, 1 MR, 115×115	400-1280	450-2390	K2028-00-N03
2d	Corner transmission, 2 MR, 115×115	400-1280	450-2390	K2032-00-N03
2e	Corner transmission, bottom, 2 MR, 115×115	400-1280	450-2390	K2029-00-N03
4a	Narrow corner transmission, 1 MR, 115×15	300-400	450-2390	K2026-00-N03
		400-600	370-550*	
10	Locking plate	—	—	***
11	Lifting plate	—	751-2390	***
12	Wrong operation safety device with sash lifter	—	751-2390	A7001-00-N03
13	Corner bearing 3×3	—	—	A5002-00-N03
13a	Corner bearing 6×22	—	—	A5004-00-N03
14	Drill-in corner hinge 3×5	—	—	A5003-00-N03
14a	Drill-in corner hinge with gasket pressure adjustment 6×12	—	—	A5007-00-N03
14b	Drill-in corner hinge with gasket pressure adjustment 6×16/26	—	—	A5006-00-N03
14c	Rebate corner hinge 20/9 left/right	—	—	A5009-09-L/R03
	Rebate corner hinge 20/13 left/right	—	—	A5009-13-L/R03
15	Stay arm bearing 3×3	—	—	A5001-00-N03
15a	Stay arm bearing 6×24	—	—	A5005-00-N03
16	Top sash hinge	—	—	K5001-**-N03
17	Cover of top sash hinge	—	—	A7004-10-N*
18	Cover of stay arm bearing	—	—	A7005-10-N*
19	Cover of the drill-in corner hinge	—	—	A7006-10-N*
19a	Cover of rebate corner hinge, left / right	—	—	A7009-00-L/R*
20	Top cover of corner bearing	—	—	A7008-10-N*
21	Bottom cover of corner bearing	—	—	A7007-10-N*
22	Turn stay arm	—	—	K5002-00-N03
22a	Turn stay arm 12/20-13 left/right	—	—	K5014-13-L/R03
	Turn stay arm 12/20-9 left/right	—	—	K5014-09-L/R03
	Turn stay arm 12/20-13 left/right	—	—	S5001-13-L03/R
	Turn stay arm 12/20-9 left/right	—	—	S5001-09-L03/R
29	Balcony catch	—	—	A7184-13-N03
29b	Balcony locking pin	—	—	A7207-00-N03
30	Concealed middle hinge, sash part	—	—	A7056-00-N03
31	Concealed middle hinge, frame part	—	—	A7057-**-N03

**Turn set**
**ECCENTRIC CUT**

Hardware set combinations

Nº	Description	Application range by width	Application range by height	Part No.
31a	Middle hinge (white)	—	—	A7185-00-N01
	Middle hinge (brown)	—	—	A7185-00-N02
	Middle hinge (gray anthracite)	—	—	A7185-00-N09
36a	Extension lock 480 mm, 1 ML	—	—	K4053-05-N03
	Extension lock 680 mm, 1 ML	—	—	K4053-07-N03
	Extension lock 880 mm, 2 ML	—	—	K4053-09-N03
38	Magnetic balcony catch, frame part	—	—	A7053-00-N03
38a	Magnetic balcony catch, sash part	—	—	A7055-**-N03
39	Extension lock 240 mm, 1 MR	—	—	K4050-02-N03
	Extension lock 480 mm, 1 MR	—	—	K4050-05-N03

\* – for decorative covers in other colors look at p. 27

\*\* – according to displacement axis of sash groove (9 mm, 10 mm, 13 mm, 14 mm)

\*\*\* – look at the section "Profile-dependent elements"



**Tilt set**

Hardware set combinations

Tilt set, eccentric cut.

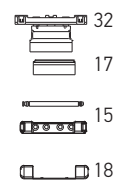
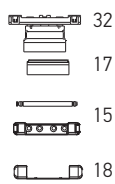
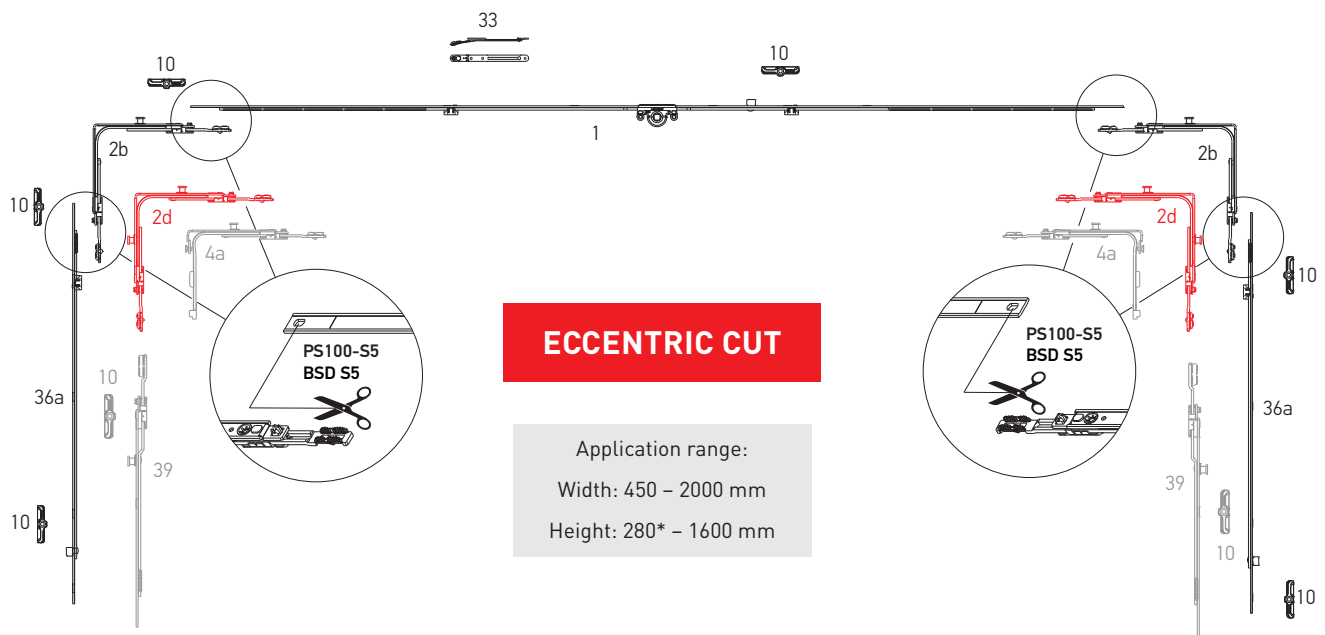
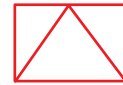

\* without extension lock



## Tilt set

**ECENTRIC CUT**

## Hardware set combinations

Nº	Description	Application range by width	Application range by height	Part No.
1	Gear variable 0, L=320, 450-550	—	450-550	K1001-02-N03
	Gear variable 1, L=520, 551-750	—	551-750	K1001-04-N03
	Gear variable 2, L=1000, 751-1230, 1 ML	—	751-1230	K1001-09-N03
	Gear variable 3, L=1200, 950-1430, 1 ML	—	950-1430	K1001-11-N03
	Gear variable 4, L=1480, 1231-1710, 2 ML	—	1231-1710	K1001-14-N03
	Gear variable 5, L=1680, 1431-1910, 2 ML	—	1431-1910	K1001-16-N03
	Gear variable 6, L=2160, 1911-2390, 3 ML	—	1911-2390	K1001-21-N03
2b	Corner transmission, 1 MR, 115×115	400-1280	450-2390	K2025-00-N03
2d	Corner transmission, 2 MR, 115×115	400-1280	450-2390	K2032-00-N03
4a	Narrow corner transmission, 1 MR, 115×15	300-400	450-2390	K2026-00-N03
		400-600	370-550*	
10	Locking plate	—	—	***
15	Stay arm bearing 3×3	—	—	A5001-00-N03
17	Cover of top sash hinge	—	—	A7004-10-N*
18	Cover of stay arm bearing	—	—	A7005-10-N*
30	Concealed middle hinge, sash part	—	—	A7056-00-N03
31	Concealed middle hinge, frame part	—	—	A7057-**-N03
31a	Middle hinge (white)	—	—	A7185-00-N01
	Middle hinge (brown)	—	—	A7185-00-N02
	Middle hinge (gray anthracite)	—	—	A7185-00-N09
32	Bottom hinges for tilt sash	—	—	A7014-**-N03
33	Tilt stay arm	—	—	A7107-00-N03
	Tilt stay arm	—	—	A7017-00-N03
36a	Extension lock 480 mm, 1 ML	—	—	K4053-05-N03
	Extension lock 680 mm, 1 ML	—	—	K4053-07-N03
	Extension lock 880 mm, 2 ML	—	—	K4053-09-N03
39	Extension lock 240 mm, 1 MR	—	—	K4050-02-N03
	Extension lock 480 mm, 1 MR	—	—	K4050-05-N03

\* – for decorative covers in other colors look at p. 27

\*\* – according to displacement axis of sash groove (9 mm, 10 mm, 13 mm, 14 mm)

\*\*\* – look at the section “Profile-depending elements”

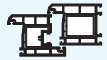

**Double sash set**

Hardware set combinations

Secondary sash of double-sash window

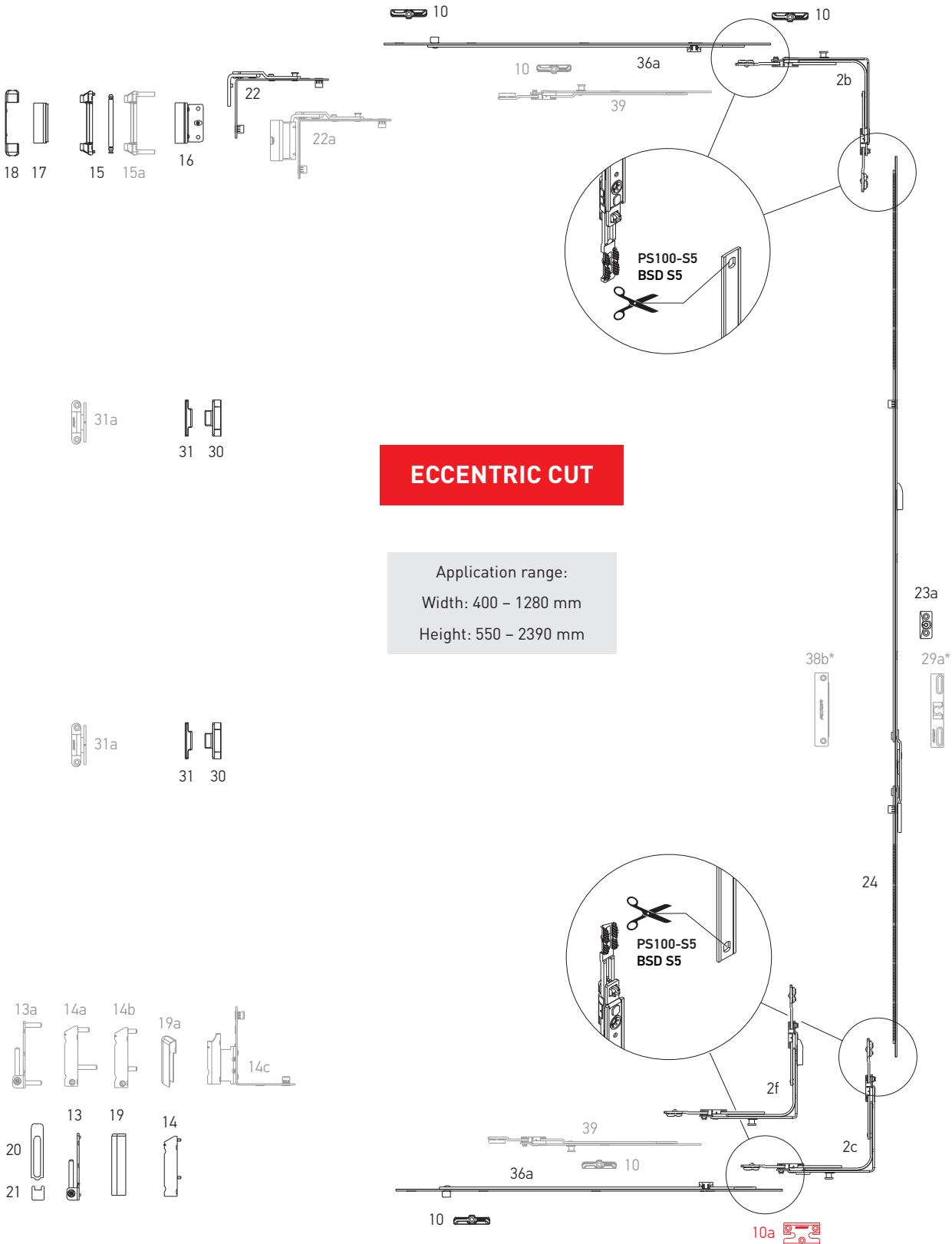
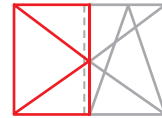

**ECCENTRIC CUT**

Application range:  
Width: 400 – 1280 mm  
Height: 550 – 2390 mm

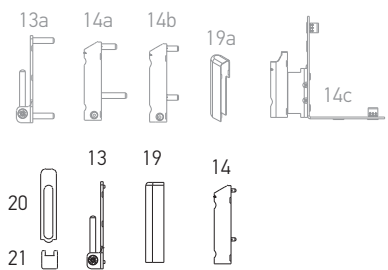

**Double sash set**

Hardware set combinations

**Main sash**

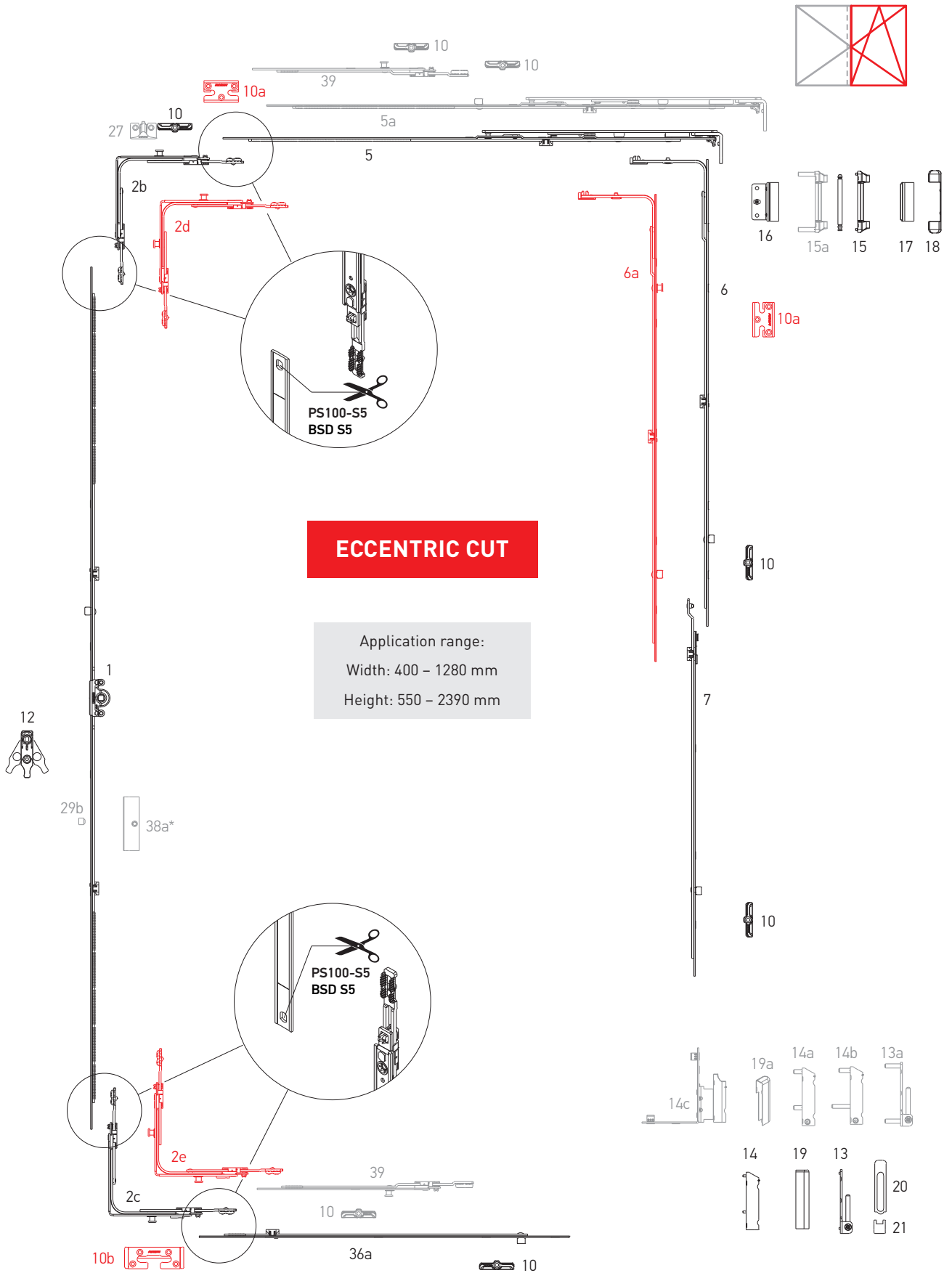

**ECCENTRIC CUT**

Application range:  
Width: 400 - 1280 mm  
Height: 550 - 2390 mm

\* - only with gear K1002-21-N03



## Double sash set

**ECCENTRIC CUT**

Hardware set combinations

Nº	Description	Application range by width	Application range by height	Part No.
1	Gear variable 1, L=520, 551-750	—	551-750	K1001-04-N03
	Gear variable 2, L=1000, 751-1230, 1 ML	—	751-1230	K1001-09-N03
	Gear variable 3, L=1200, 950-1430, 1 ML	—	950-1430	K1001-11-N03
	Gear variable 5, L=1680, 1431-1910, 2 ML	—	1431-1910	K1001-16-N03
	Gear variable 6, L=2160, 1911-2390, 3 ML	—	1911-2390	K1001-21-N03
2b	Corner transmission, 1 MR, 115×115	400-1280	450-2390	K2025-00-N03
2c	Corner transmission, bottom, 1 MR, 115×115	400-1280	450-2390	K2028-00-N03
2d	Corner transmission, 2 MR, 115×115	400-1280	450-2390	K2032-00-N03
2e	Corner transmission, bottom, 2 MR, 115×115	400-1280	450-2390	K2029-00-N03
2f	Corner transmission, double sash, bottom, 1 MR, 115×115	400-1280	550-2390	K2030-00-N03
5	Stay arm 1, L=485, 400-600	400-600	—	K3001-05-N03
	Stay arm 2, L=685, 601-800	601-800	—	K3001-07-N03
	Stay arm 3, L=925, 801-1040, 1 ML	801-1040	—	K3001-09-N03
	Stay arm 4, L=1165, 1041-1280, 1 ML	1041-1280	—	K3001-11-N03
5a	Stay arm 2, L=685, 601-800, 1 ML	601-800	—	K3001-57-N03
6	Middle lock L=400, 1 ML	600-1000	600-1000	K4001-04-N03
	Middle lock L=650, 1 ML	850-1250	850-1250	K4001-06-N03
	Middle lock L=720, 1 ML	920-1320	920-1320	K4001-07-N03
	Middle lock L=820, 1 ML	1251-1430	1251-1430	K4001-08-N03
	Middle lock L=1130, 2 ML	—	1251-1730	K4001-11-N03
6a	Middle lock L=400, 1 MR + 1 ML	600-1000	600-1000	K4008-04-N03
	Middle lock L=650, 1 MR + 1 ML	850-1250	850-1250	K4008-06-N03
	Middle lock L=820, 1 MR + 1 ML	1251-1430	1251-1430	K4008-08-N03
	Middle lock L=1130, 1 MR + 2 ML	—	1251-1730	K4008-11-N03
7	Middle lock extension, 1 ML, 480 mm	—	1710-2210	K4005-05-N03
	Middle lock extension, 1 ML, 680 mm	—	2231-2390	K4005-07-N03
10	Locking plate	—	—	***
10a	Locking plate safety	—	—	***
10b	Tilt locking plate safety	—	—	***
12	Wrong operation safety device with sash lifter	—	751-2390	A7001-00-N03
13	Corner bearing 3×3	—	—	A5002-00-N03
13a	Corner bearing 6×22	—	—	A5004-00-N03
14	Drill-in corner hinge 3×5	—	—	A5003-00-N03
14a	Drill-in corner hinge with gasket pressure adjustment 6×12	—	—	A5006-00-N03
14b	Drill-in corner hinge with gasket pressure adjustment 6×16/26	—	—	A5007-00-N03
14C	Rebate corner hinge 20/9 left	—	—	A5009-09-L03
	Rebate corner hinge 20/9 right	—	—	A5009-09-R03
	Rebate corner hinge 20/13 left	—	—	A5009-13-L03
	Rebate corner hinge 20/13 right	—	—	A5009-13-R03
15	Stay arm bearing 3×3	—	—	A5001-00-N03
15a	Stay arm bearing 6×24	—	—	A5005-00-N03
16	Top sash hinge	—	—	K5001-**-N03





## Double sash set

**ECCENTRIC CUT**

## Hardware set combinations

Nº	Description	Application range by width	Application range by height	Part No.
17	Cover of top sash hinge	—	—	A7004-10-N*
18	Cover of stay arm bearing	—	—	A7005-10-N*
19	Cover of the drill-in corner hinge	—	—	A7006-10-N*
19a	Cover of rebate corner hinge, left / right	—	—	A7009-00-L/R*
20	Top cover of corner bearing	—	—	A7008-10-N*
21	Bottom cover of corner bearing	—	—	A7007-10-N*
22	Turn stay arm	—	—	K5002-00-N03
22a	Turn stay arm 12/20-13 left/right	—	—	K5014-13-L/R03
	Turn stay arm 12/20-9 left/right	—	—	K5014-09-L/R03
	Turn stay arm 12/20-13 left/right	—	—	S5001-13-L03/R
	Turn stay arm 12/20-9 left/right	—	—	S5001-09-L03/R
23a	Lifting plate plate for double-sash window	—	—	A6001-00-N03
24	Double-sash gear 1 L=520, 551-750	—	551-750	K1002-04-N03
	Double-sash gear 2 L=720, 751-950	—	751-950	K1002-06-N03
	Double-sash gear 3 L=1200, 951-1430	—	951-1430	K1002-11-N03
	Double-sash gear 4 L=1680, 1431-1910	—	1431-1910	K1002-16-N03
	Double-sash gear 5 L=2160, 1911-2390	—	1911-2390	K1002-21-N03
27	Locking plate, integrated slit	—	—	***
29a	Balcony catch for double-sash gear	—	1911-2390	A7047-00-N03
29b	Balcony locking pin	—	—	A7207-00-N03
30	Concealed middle hinge, sash part	—	—	A7056-00-N03
31	Concealed middle hinge, frame part	—	—	A7057-**-N03
31a	Middle hinge (white)	—	—	A7185-00-N01
	Middle hinge (brown)	—	—	A7185-00-N02
	Middle hinge (gray anthracite)	—	—	A7185-00-N09
36a	Extension lock 480 mm, 1 ML	—	—	K4053-05-N03
	Extension lock 680 mm, 1 ML	—	—	K4053-07-N03
	Extension lock 880 mm, 2 ML	—	—	K4053-09-N03
38a	Magnetic balcony catch, sash part	—	—	A7055-**-N03
38b	Magnetic balcony catch for double-sash gear, frame part	—	—	A7054-00-N03
39	Extension lock 240 mm, 1 MR	—	—	K4050-02-N03
	Extension lock 480 mm, 1 MR	—	—	K4050-05-N03

\* – for decorative covers in other colors look at p. 27

\*\* – according to displacement axis of sash groove (9 mm, 10 mm, 13 mm, 14 mm)

\*\*\* – look at the section "Profile-dependent elements"



**Double sash set "First Tilt"**

Hardware set combinations

Secondary sash of double-sash window "First Tilt"

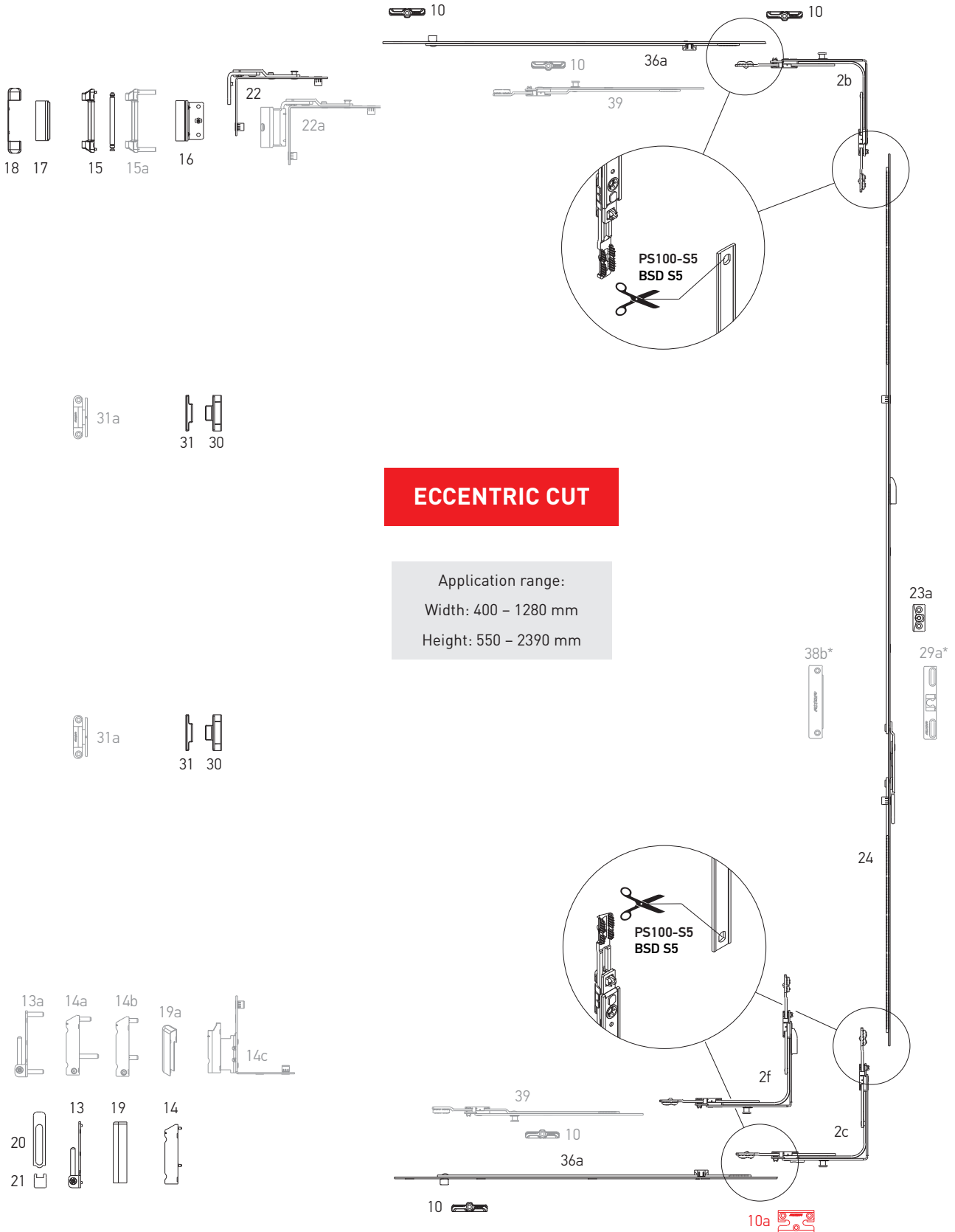
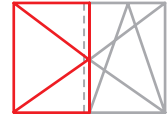

**ECCENTRIC CUT**

Application range:  
Width: 400 – 1280 mm  
Height: 550 – 2390 mm



**Double sash set "First Tilt"**

Hardware set combinations

Main sash "First Tilt"

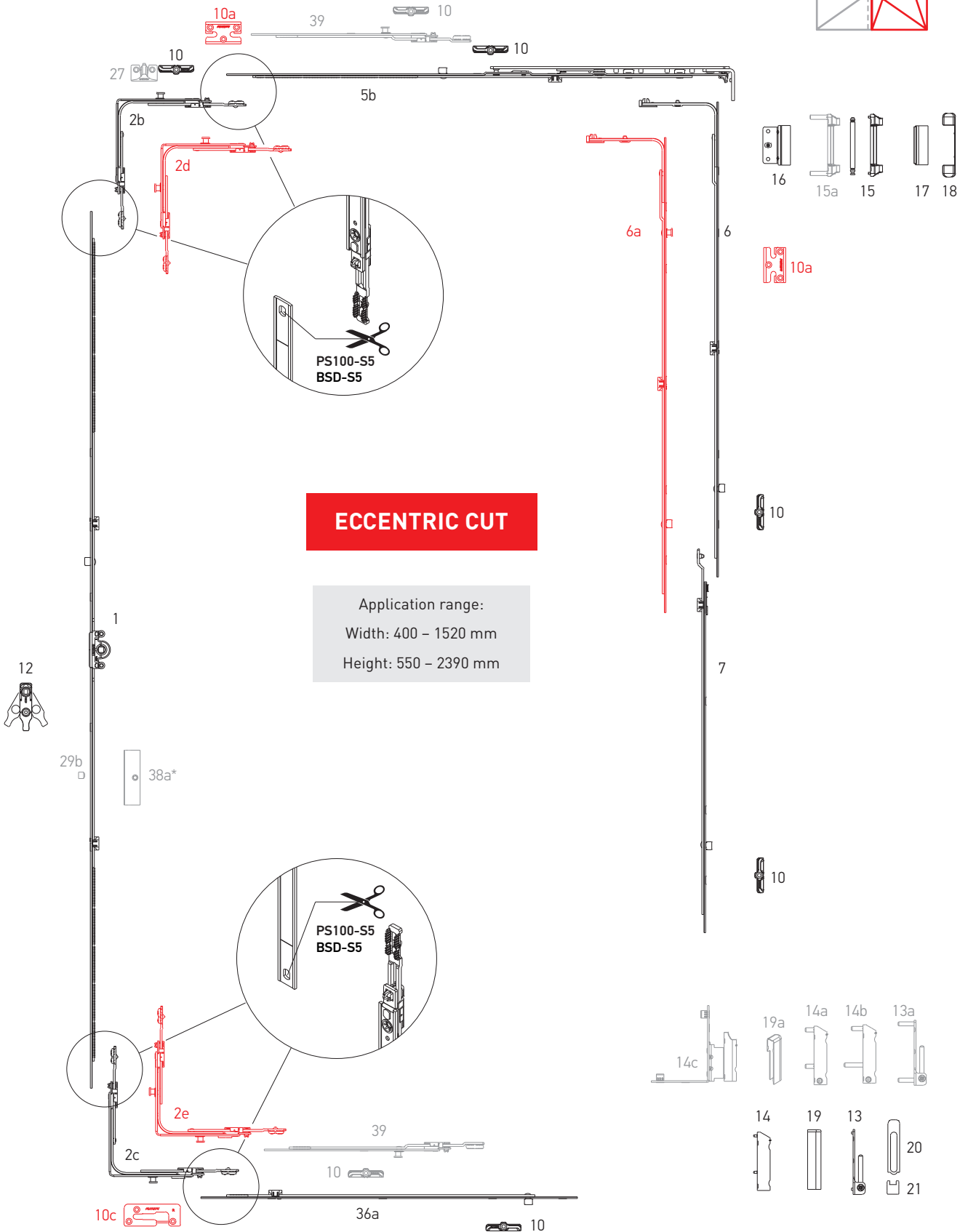
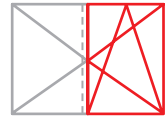

**ECCENTRIC CUT**

Application range:  
Width: 400 - 1520 mm  
Height: 550 - 2390 mm



## Double sash set "First Tilt"

## ECCENTRIC CUT

Hardware set combinations

Nº	Description	Application range by width	Application range by height	Part No.
1	Gear variable 1, L=520, 551-750	—	551-750	K1001-04-N03
	Gear variable 2, L=1000, 751-1230, 1 ML	—	751-1230	K1001-09-N03
	Gear variable 3, L=1200, 950-1430, 1 ML	—	950-1430	K1001-11-N03
	Gear variable 5, L=1680, 1431-1910, 2 ML	—	1431-1910	K1001-16-N03
	Gear variable 6, L=2160, 1911-2390, 3 ML	—	1911-2390	K1001-21-N03
2b	Corner transmission, 1 MR, 115×115	400-1280	450-2390	K2025-00-N03
2c	Corner transmission, bottom, 1 MR, 115×115	400-1280	450-2390	K2028-00-N03
2d	Corner transmission, 2 MR, 115×115	400-1280	450-2390	K2032-00-N03
2e	Corner transmission, bottom, 2 MR, 115×115	400-1280	450-2390	K2029-00-N03
2f	Corner transmission, double sash, bottom, 1 MR, 115×115	400-1280	550-2390	K2030-00-N03
5b	Stay arm 1, "First Tilt", L=485, 400-600	400-600	—	K3014-05-N03
	Stay arm 2, "First Tilt", L=685, 601-800	601-800	—	K3014-07-N03
	Stay arm 3, "First Tilt", L=915, 801-1040, 1 ML	801-1040	—	K3014-09-N03
	Stay arm 4, "First Tilt", L=1165, 1041-1280, 1 ML	1041-1280	—	K3014-11-N03
6	Middle lock L=400, 1 ML	—	600-1000	K4001-04-N03
	Middle lock L=650, 1 ML	—	850-1250	K4001-06-N03
	Middle lock L=720, 1 ML	—	920-1320	K4001-07-N03
	Middle lock L=820, 2 ML	—	1251-1430	K4001-08-N03
	Middle lock L=1130, 2 ML	—	1251-1730	K4001-11-N03
6a	Middle lock L=400, 1 MR + 1 ML	—	600-1000	K4008-04-N03
	Middle lock L=650, 1 MR + 1 ML	—	850-1250	K4008-06-N03
	Middle lock L=820, 1 MR + 1 ML	—	1251-1430	K4008-08-N03
	Middle lock L=1130, 1 MR + 2 ML	—	1251-1730	K4008-11-N03
7	Middle lock extension, 1 ML, 480 mm	—	850-1230	K4005-05-N03
	Middle lock extension, 1 ML, 680 mm	—	1231-1430	K4005-07-N03
10	Locking plate	—	—	***
10a	Locking plate safety	—	—	***
10C	Tilt locking plate "First Tilt", left / right	—	—	***
12	Wrong operation safety device with sash lifter	—	751-2390	A7001-00-N03
13	Corner bearing 3×3	—	—	A5002-00-N03
13a	Corner bearing 6×22	—	—	A5004-00-N03
14	Drill-in corner hinge 3×5	—	—	A5003-00-N03
14a	Drill-in corner hinge with gasket pressure adjustment 6×12	—	—	A5006-00-N03
14b	Drill-in corner hinge with gasket pressure adjustment 6×12/26	—	—	A5007-00-N03
14C	Rebate corner hinge 20/9 left	—	—	A5009-09-L03
	Rebate corner hinge 20/9 right	—	—	A5009-09-R03
	Rebate corner hinge 20/13 left	—	—	A5009-13-L03
	Rebate corner hinge 20/13 right	—	—	A5009-13-R03
15	Stay arm bearing 3×3	—	—	A5001-00-N03
15a	Stay arm bearing 6×24	—	—	A5005-00-N03



## Double sash set "First Tilt"

## ECCENTRIC CUT

Hardware set combinations

Nº	Description	Application range by width	Application range by height	Part No.
16	Top sash hinge	—	—	***
17	Cover of top sash hinge	—	—	A7004-10-N*
18	Cover of stay arm bearing	—	—	A7005-10-N*
19	Cover of the drill-in corner hinge	—	—	A7006-10-N*
19a	Cover of rebate corner hinge, left / right	—	—	A7009-00-L/R*
20	Top cover of corner bearing	—	—	A7008-10-N*
21	Bottom cover of corner bearing	—	—	A7007-10-N*
22	Turn stay arm	—	—	K5002-00-N03
22a	Turn stay arm 12/20-13 left/right	—	—	K5014-13-L/R03
	Turn stay arm 12/20-9 left/right	—	—	K5014-09-L/R03
	Turn stay arm 12/20-13 left/right	—	—	S5001-13-L03/R
	Turn stay arm 12/20-9 left/right	—	—	S5001-09-L03/R
23a	Lifting plate plate for double-sash window	—	—	***
24	Double-sash gear 1 L=520, 551-750	—	551-750	K1002-04-N03
	Double-sash gear 2 L=720, 751-950	—	751-950	K1002-06-N03
	Double-sash gear 3 L=1200, 951-1430	—	951-1430	K1002-11-N03
	Double-sash gear 4 L=1680, 1431-1910	—	1431-1910	K1002-16-N03
	Double-sash gear 5 L=2160, 1911-2390	—	1911-2390	K1002-21-N03
27	Locking plate, integrated slit	—	—	***
29a	Balcony catch for double-sash gear	—	1911-2390	A7047-00-N03
29b	Balcony locking pin	—	—	A7207-00-N03
30	Concealed middle hinge, sash part	—	—	A7056-00-N03
31	Concealed middle hinge, frame part	—	—	A7057-**-N03
31a	Middle hinge (white)	—	—	A7185-00-N01
	Middle hinge (brown)	—	—	A7185-00-N02
	Middle hinge (gray anthracite)	—	—	A7185-00-N09
36a	Extension lock 480 mm, 1 ML	—	—	K4053-05-N03
	Extension lock 680 mm, 1 ML	—	—	K4053-07-N03
	Extension lock 880 mm, 2 ML	—	—	K4053-09-N03
38a	Magnetic balcony catch, sash part	—	—	A7055-**-N03
38b	Magnetic balcony catch for double-sash gear	—	—	A7054-13-N03
39	Extension lock 240 mm, 1 MR	—	—	K4050-02-N03
	Extension lock 480 mm, 1 MR	—	—	K4050-05-N03

\* – for decorative covers in other colors look at p. 27

\*\* – according to displacement axis of sash groove (9 mm, 10 mm, 13 mm, 14 mm)

\*\*\* – look at the section "Profile-depending elements"

**AXOR**<sup>®</sup>

**KOMFORT LINE K-3**

Smart&Quick

Tools

Instalation

Adjustments

AXOR



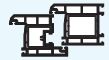

### Information for an adjustment of jigs constant gear

### Installation tools

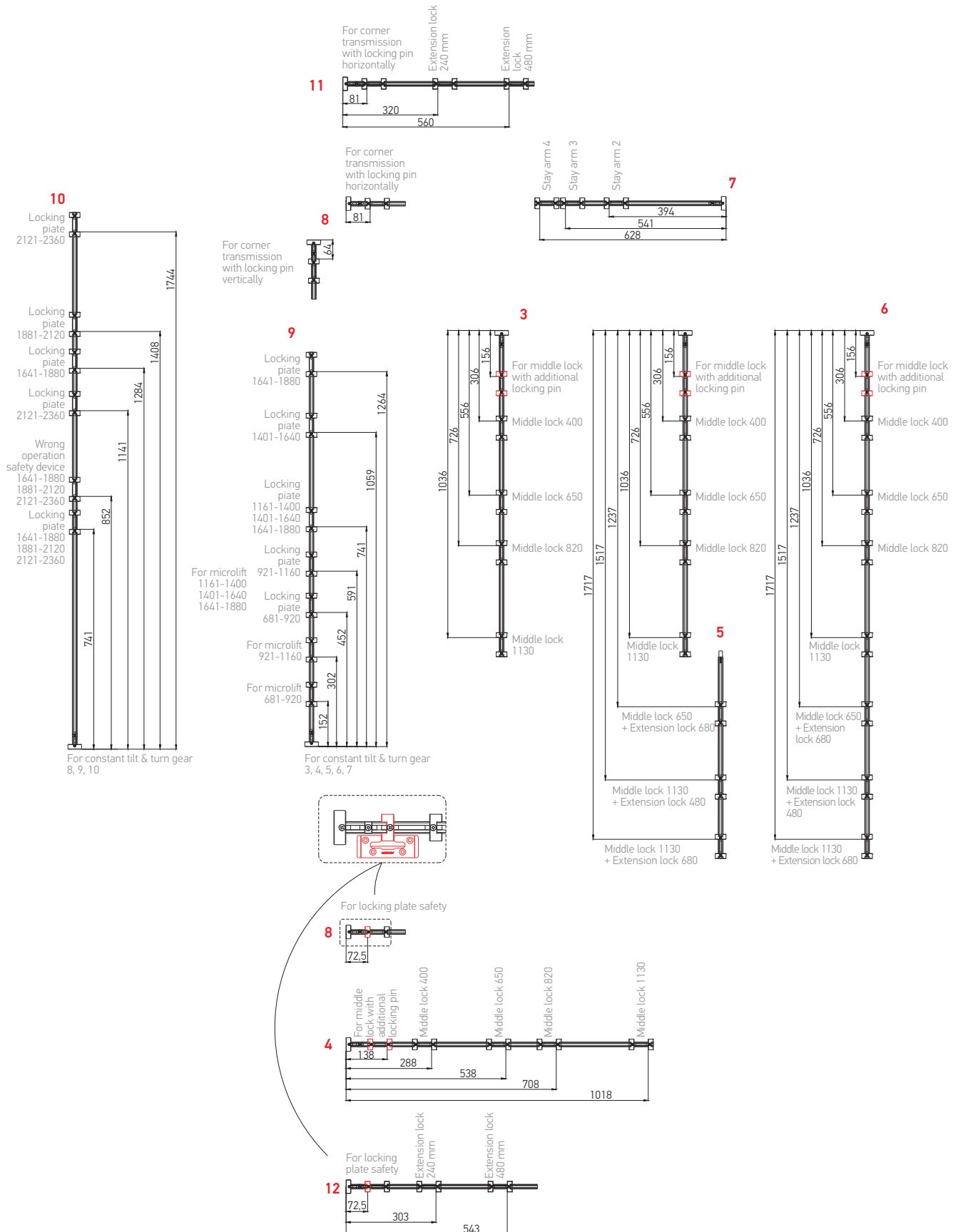

All dimensions are approximate and are subject to verification during production start-up.





## Locking plate jigs

### Installation tools

Nº	Description	Designation	Part No.
1	Telescopic jig GV 2	For tilt-and-turn gear 5, 6. The handle is positioned in center.	A7024-02-N00
2	Telescopic jig GV 1	For tilt-and-turn gear 2,3,4. The handle is positioned in center.	A7024-01-N00
3	Linear jig MLV	For all vertical middle locks.	A7026-00-N00
4	Linear jig MLH	For all horizontal middle locks.	A7028-00-N00
5	Linear jig MLEV + MLV	For all vertical middle lock extensions + for all vertical middle locks (set).	A7027-00-N00
6	Linear jig MLMLEV	For all vertical middle locks, all middle lock extensions.	A7231-00-N00
7	Linear jig SA	For stay-arms of all sizes.	A7032-00-N00
8	Linear jig CTCP 1	For corner transmission with vertical locking pin.	A7025-00-N00
9	Linear jig CG	For constant tilt & turn gear 3, 4, 5, 6, 7.	A7065-01-N00
10	Linear jig CG	For constant tilt & turn gear 8, 9, 10.	A7065-02-N00
11	Linear jig EL-T	For extension locks with catcher, top.	A7229-00-N00
12	Linear jig EL-B	For extension locks with catcher, bottom.	A7230-00-N00



# Installation of frame hardware components

## Installation tools

### Installation of frame hardware components

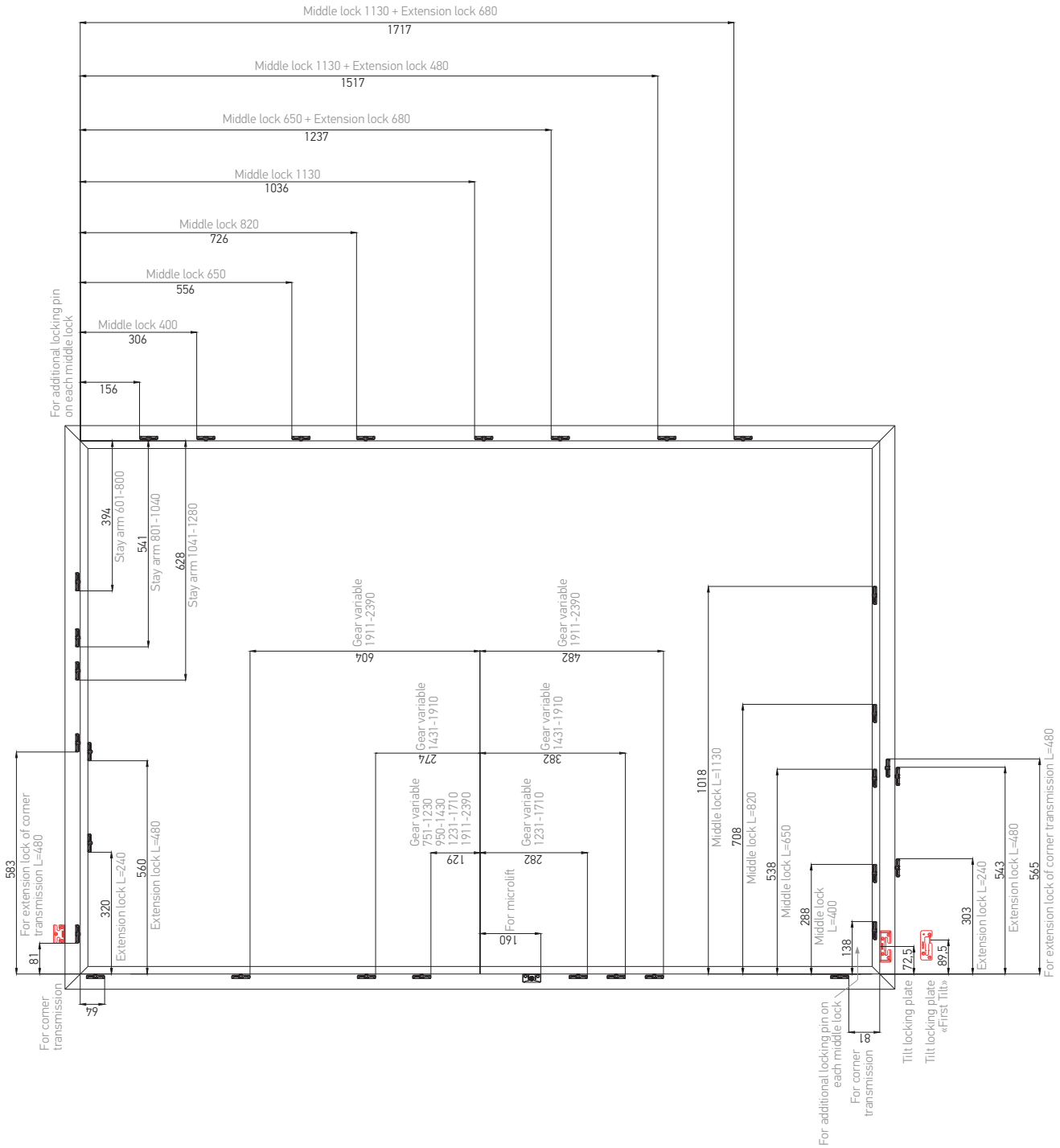



# Installation of frame hardware components

Installation tools

## Installation of frame hardware components using a constant gears

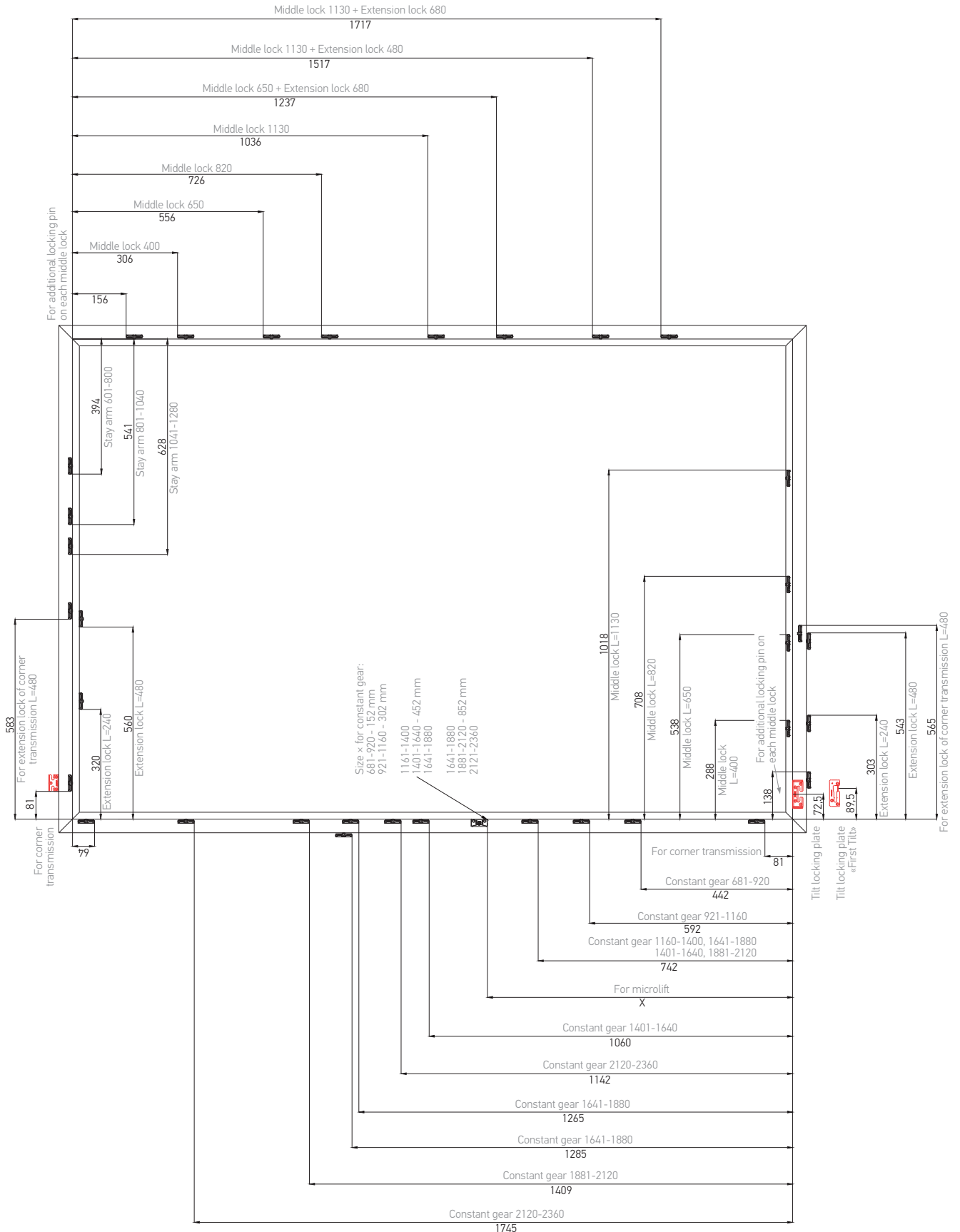

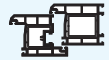

**Location of locking plates**

Installation tools

Location of locking plates with using of single turn gears, backset of ones is 15 mm.

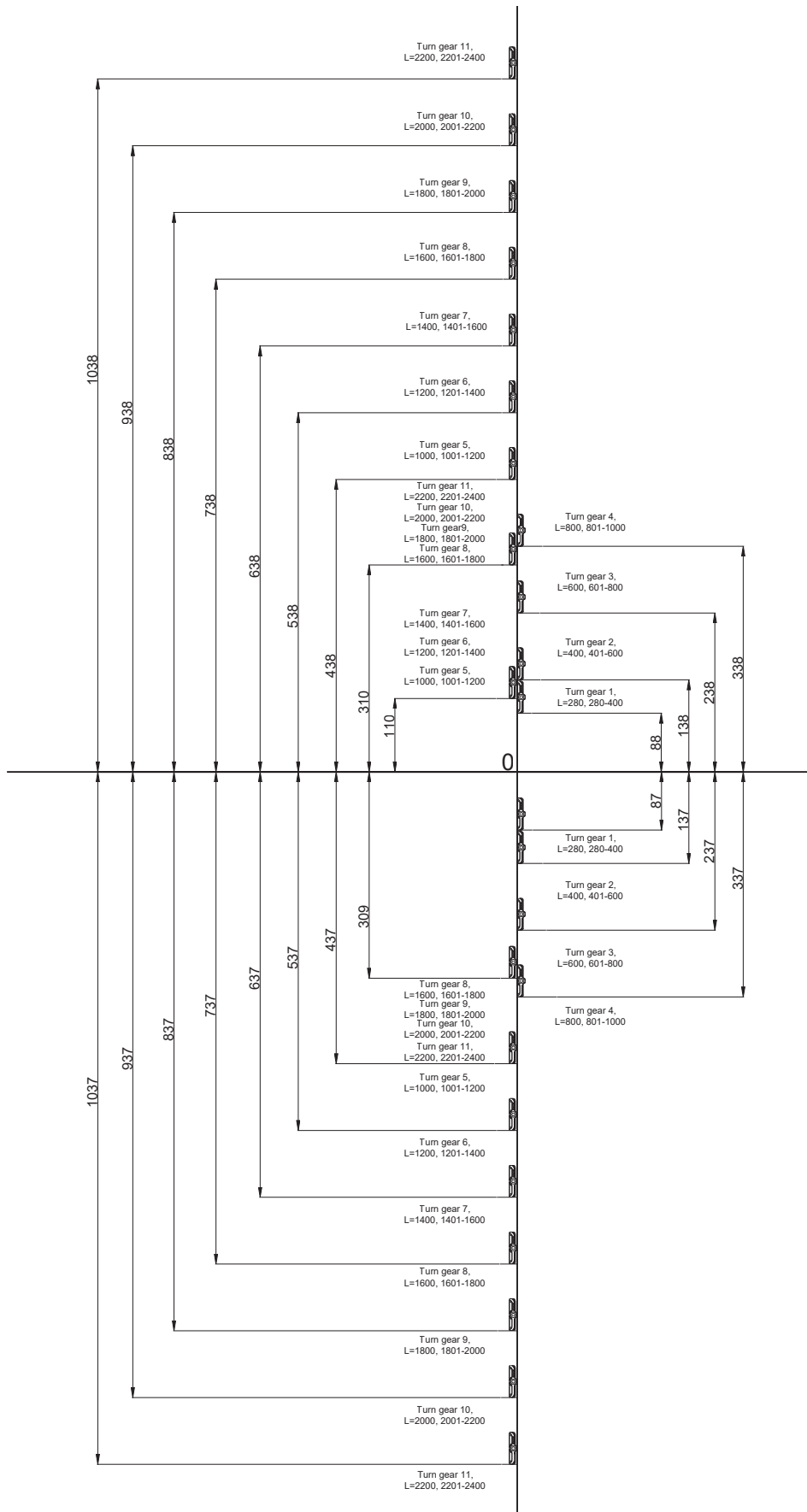



Jigs for hinges

Installation tools

Drilling jig for frame hinges

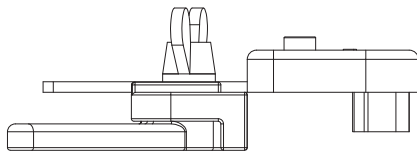
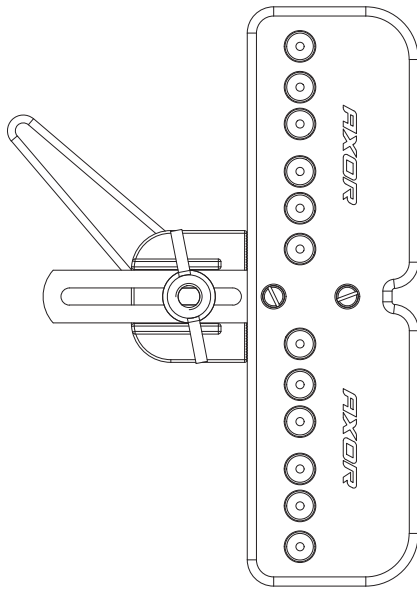

Drilling jig for sash hinges

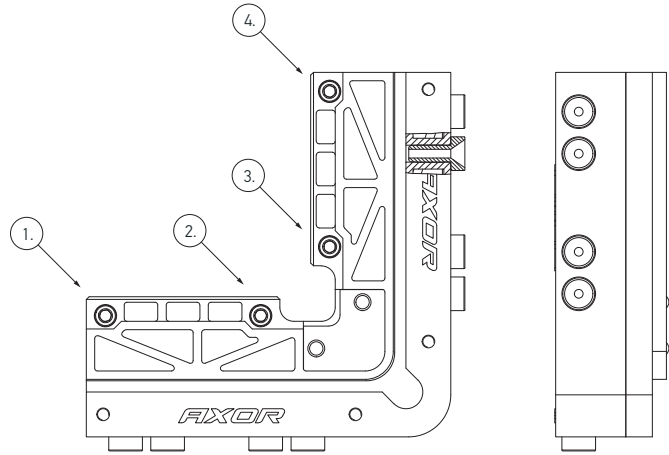

1-4. Adjustment screws use for jig fixation in sash groove.

Adjustment plate



Description	Profile	Designation	Tool		Part No.
Drilling jig for frame hinges	12/20	For drilling holes for top and bottom frame hinges	drill Ø3	50	A7002-00-N09
Drilling jig for frame hinges	12/21	For drilling holes for top and bottom frame hinges	drill Ø3	50	A7002-20-N09
Drilling jig for sash hinges	12/20-13; 12/20-9	For drilling holes for bottom sash hinge	drill Ø3	80	A7003-00-N09
Drilling jig for sash hinges	12/21-13; 12/21-9	For drilling holes for bottom sash hinge	drill Ø3	80	A7003-20-N09
Adjustment plate 0,5 mm	—	For sash jig adjustment	—	1	10073-05-N08
Adjustment plate 0,7 mm	—	For sash jig adjustment	—	1	10073-07-N08
Adjustment plate 1 mm	—	For sash jig adjustment	—	1	10073-10-N08



**Jigs for hinges 130 kg**

Installation tools

**Drilling jig for frame hinges 130 kg**

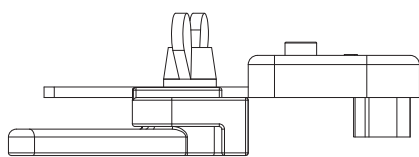
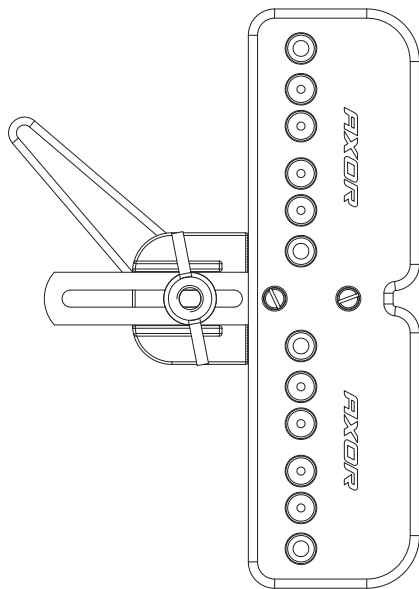

**Drilling jig for sash hinges 130 kg**

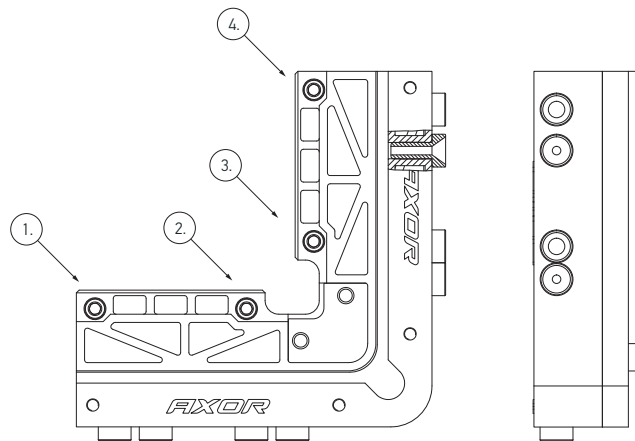

1-4. Adjustment screws use for jig fixation in sash groove.

**Adjustment plate**



Description	Profile	Designation	Tool		Part No.
Drilling jig for frame hinges 130 kg	12/20	For drilling holes for top and bottom frame hinges	drill Ø3/6	50	A7002-10-N09
Drilling jig for frame hinges 130 kg	12/21	For drilling holes for top and bottom frame hinges	drill Ø3/6	50	A7002-30-N09
Drilling jig for sash hinges 130 kg	12/20-13; 12/20-9	For drilling holes for bottom sash hinge	drill Ø3/6	80	A7003-10-N09
Drilling jig for sash hinges 130 kg	12/21-13; 12/21-9	For drilling holes for bottom sash hinge	drill Ø3/6	80	A7003-30-N09
Adjustment plate 0,5 mm	—	For sash jig adjustment	—	1	10073-05-N08
Adjustment plate 0,7 mm	—	For sash jig adjustment	—	1	10073-07-N08
Adjustment plate 1 mm	—	For sash jig adjustment	—	1	10073-10-N08



**Adjustment keys**

Installation tools

Allen key U type

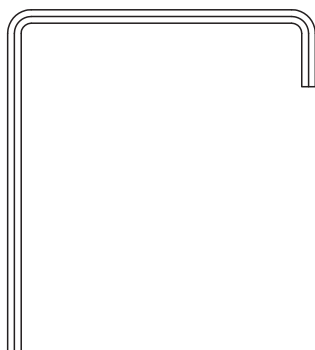

Allen key (L type plastic coated)

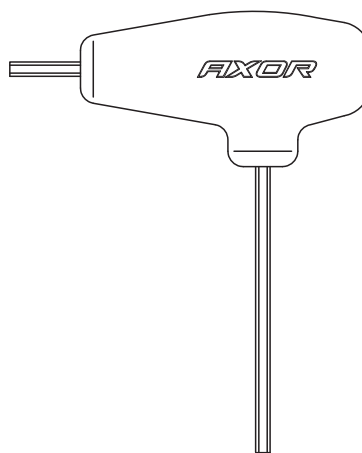

Mounting square handle

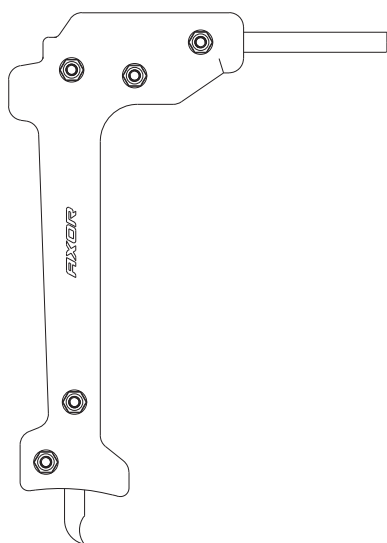

Description	Product group		Part No.
Allen key U type	K3-S+	100	A7020-00-N03
Allen key (L type plastic coated)	K3-S+	12	A7021-00-N03
AXOR mounting square handle	K3-S+	1	A7179-00-N03



**Installation recommendations**  
**Adjustment**

Installation tools

**Sash installation**

The pin should be installed only when the sash has been closed and the handle is in "Tilt" position.  
Caution!  
After the pin has been installed to rotate the handle to "Closed" position.

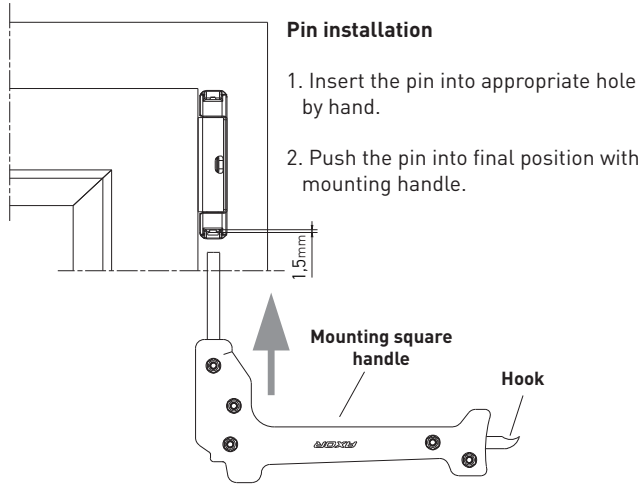

**Sash removing**

The pin should be removed only when the window has been closed and the handle is in "Tilted" position. Then, after the pin has been removed to turn the handle to "Open" position and to remove the sash.

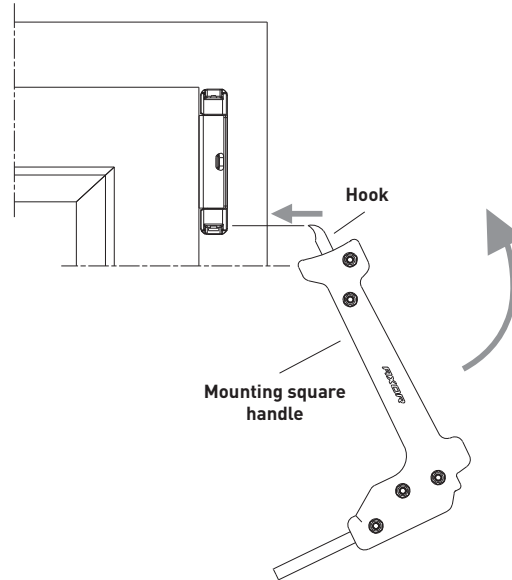

**Stay arm**

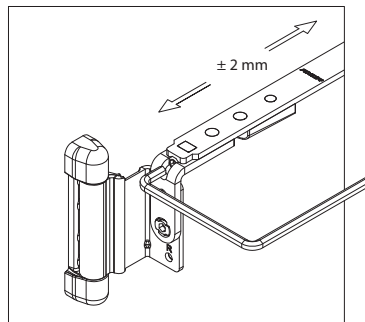
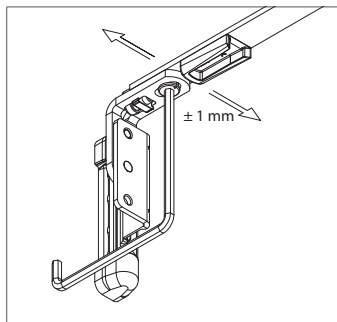

**Drill-in corner hinge**

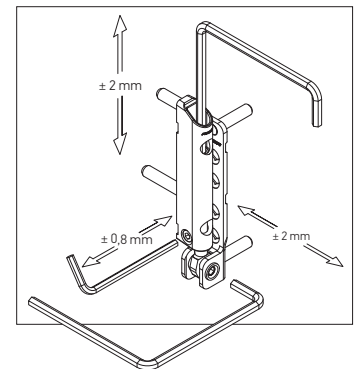

**Turn stay arm**

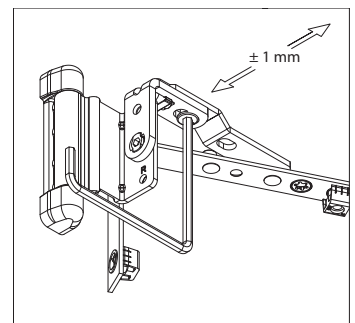
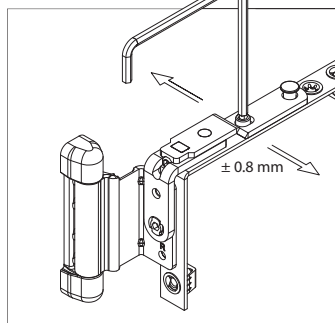
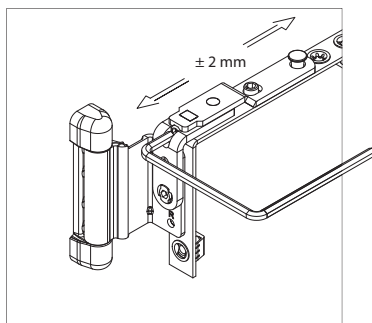





**Installation recommendations**  
**Adjustment**

Installation tools

Locking pin	ML	Rotation direction	Adjustment limits
			+/-1

Locking pin	MR	Rotation direction	Adjustment limits
			+/-1

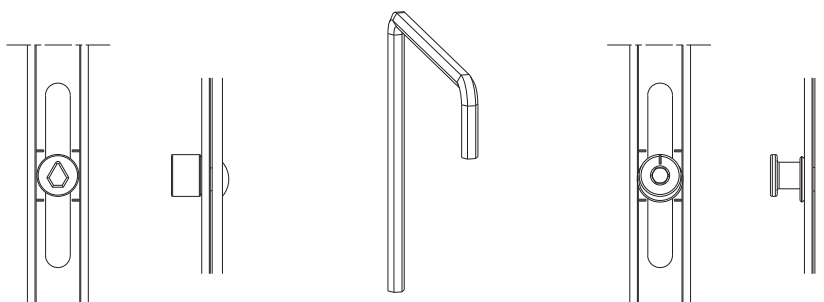

**Installation recommendations**

For hinge installation it is recommended to drill 3-mm hole in plastic and reinforcement profile, then to screw the hinge with screws without drill-bit.

For normal hinge load of 100/130 kg, it is **NECESSARY** to fix the hinge that ALL screws DIN 7982 3.9 × 38 mm (4 pcs) go into a reinforcing profile of a frame. If only 3 self-tapping screws go into the reinforcing profile of the frame, the weight of a sash is limited up to 80 kg, if only two self-tapping screws the weight of the sash is limited up to 70 kg.





## Fixing the connection

Installation tools

### Straight cut

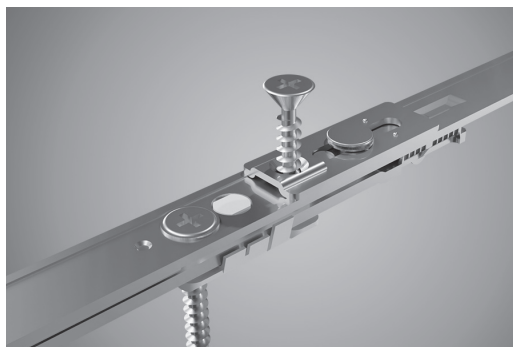
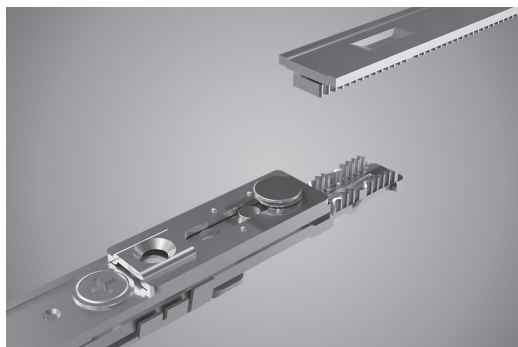

### Eccentric cut

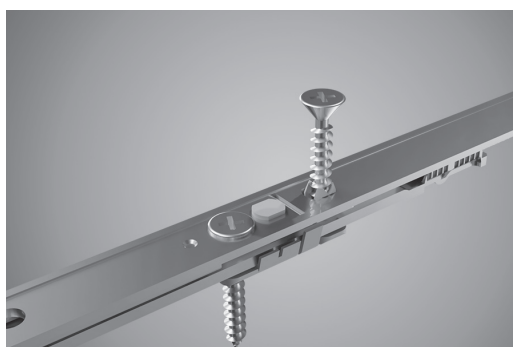
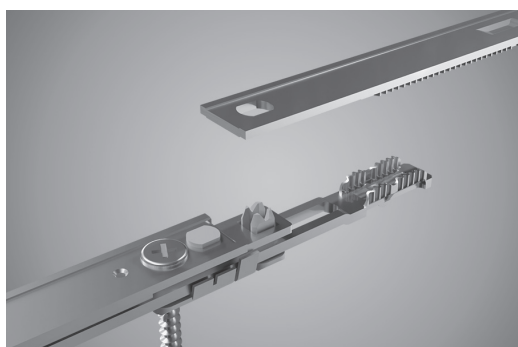



**Punching machines**

Installation tools

Punching machines

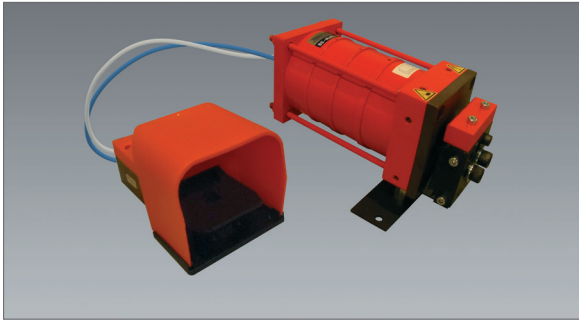

**BS - Multi - Max® PS 100**

- Integrated blow out function
- Straight cuts
- Punching Force at 6bar .....15 kN
- Working Pressure min ..... 6-8 bar
- Working Pressure max. ....8 bar
- Foot switch
- Designed for small up to medium size production

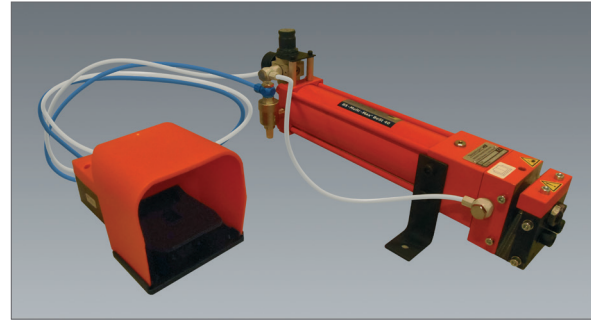

**BS - Multi - Max® BeSt40**

- Hydropneumatic drive
- Straight cut
- Working Pressure ..... 6-8 bar
- Punching Force at 6,75 bar .....40 kN
- Max. punching force .....60 kN
- Max. pressure.....8 bar
- Foot control

The rulers

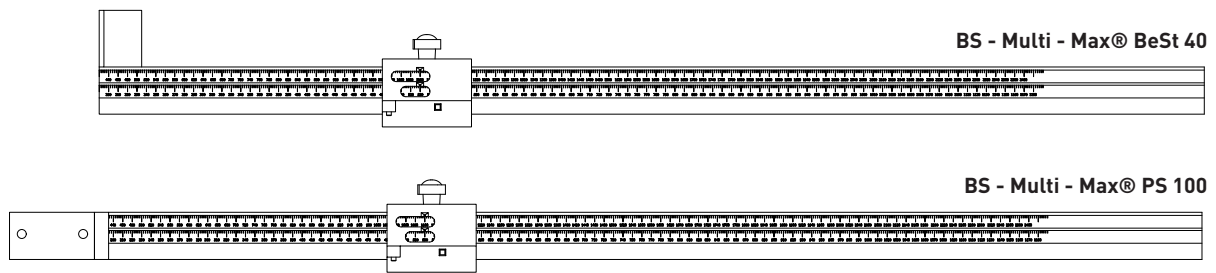

Description	Part No.
Punching machine BS-Multi-MAX BeSt40 with foot control	BeSt40-SVGL20
Punching machine BS-Multi-MAX PS100 with foot control	PS100-4-G-A-O-2-O
The ruler BS-Multi-MAX BeSt 40	A7041-01-N03
The ruler BS-Multi-MAX PS100	A7041-02-N03
The ruler for constant gears K3, BS-Multi-MAX BeSt 40	A7041-05-L03/R03
The ruler for constant gears K3, BS-Multi-MAX PS100	A7041-06-L03/R03



**Punching machines**

Installation tools

Punching machines



**PS100-3-S5-GL20**

- Integrated blow out function
- Eccentric cut
- Hydropneumatic drive 0,6 MPa (6 bar) ..... 15 kN
- Working pressure, min.....6 bar
- Working pressure, max..... 1 MPa (10 bar)
- Foot switch
- Designed for small up to medium size production



**BSD-S5-SHGL20**

- Hydropneumatic drive
- Eccentric cut
- Working pressure..... 6-10 bar
- Operating pressure ..... 6 bar
- Matrix ..... 28 kN
- Push rod ..... 18 kN
- Maximum pressure ..... 10 bar
- Foot switch

The rulers

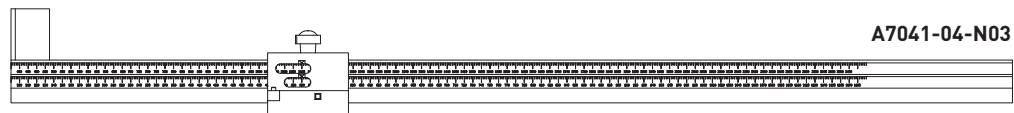

**A7041-04-N03**

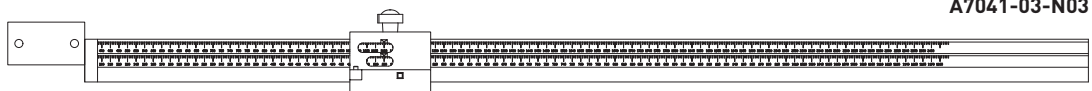

**A7041-03-N03**

Description	Part No.
Punching machine BSD-"S5-SHGL20, left with foot control	BSD-S5-SHGL20
Punching machine BS-Multi-MAX PS100 with foot control	PS100-3-S5-GL20
The ruler BSD-S5-SHGL20	A7041-03-N03
The ruler PS100-3-S5-GL20	A7041-04-N03

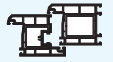

An order of the hardware installation

Installation tools

An order of the hardware installation for a sash, straight cut

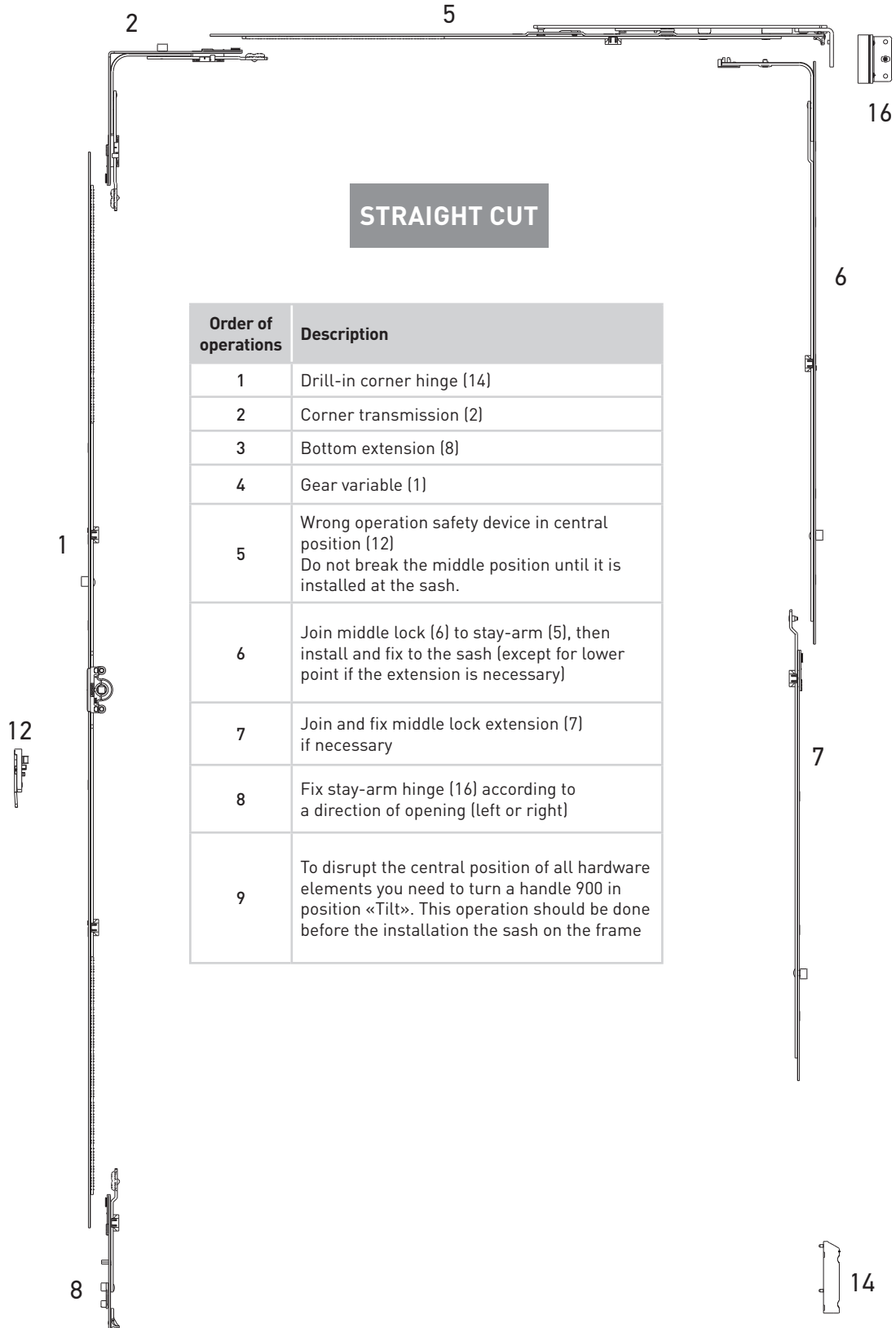



An order of the hardware installation

Installation tools

An order of the hardware installation for a sash, eccentric cut

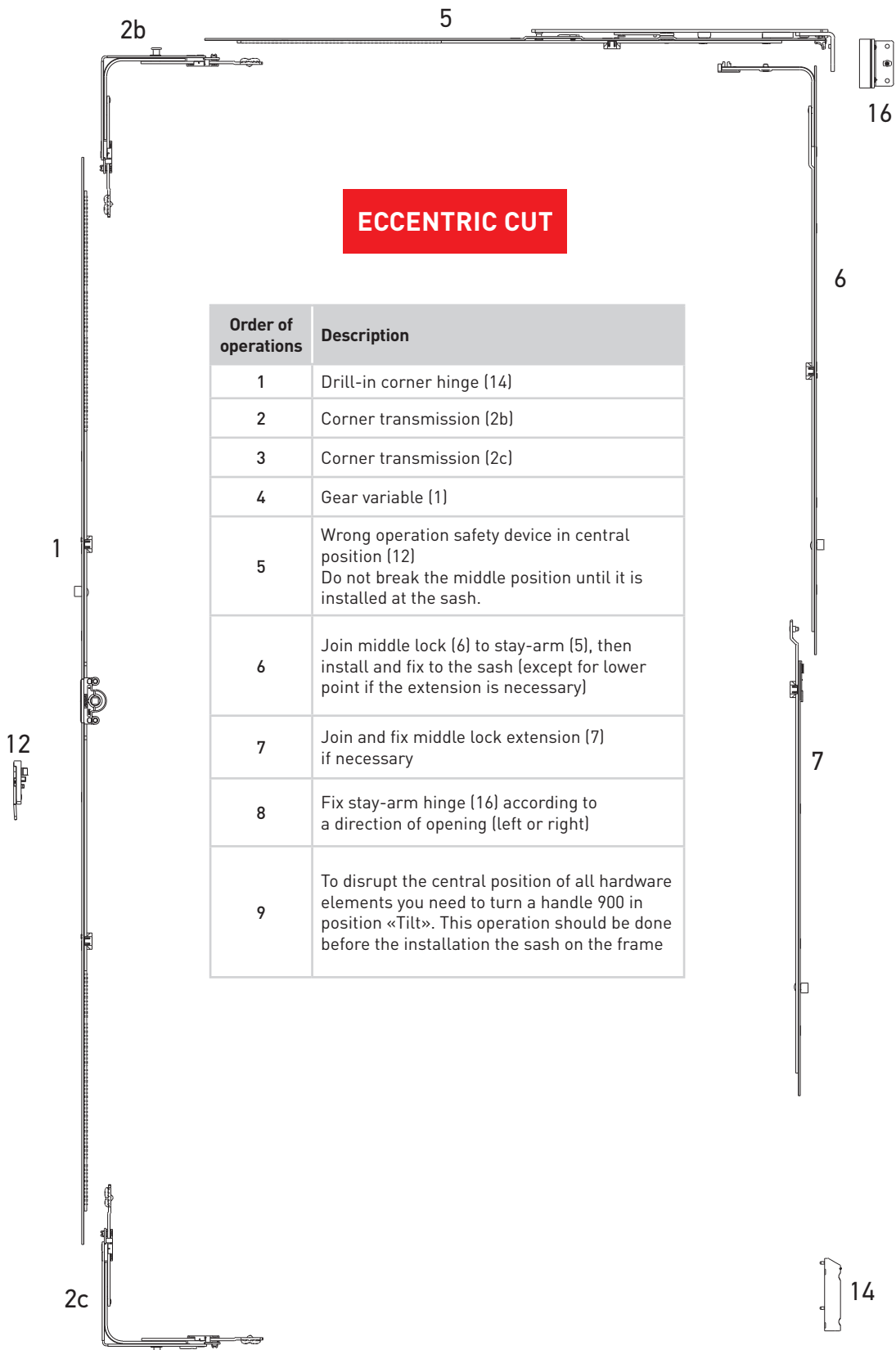

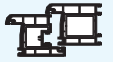

**An order of the hardware installation**

Installation tools

An order of the hardware installation for a frame

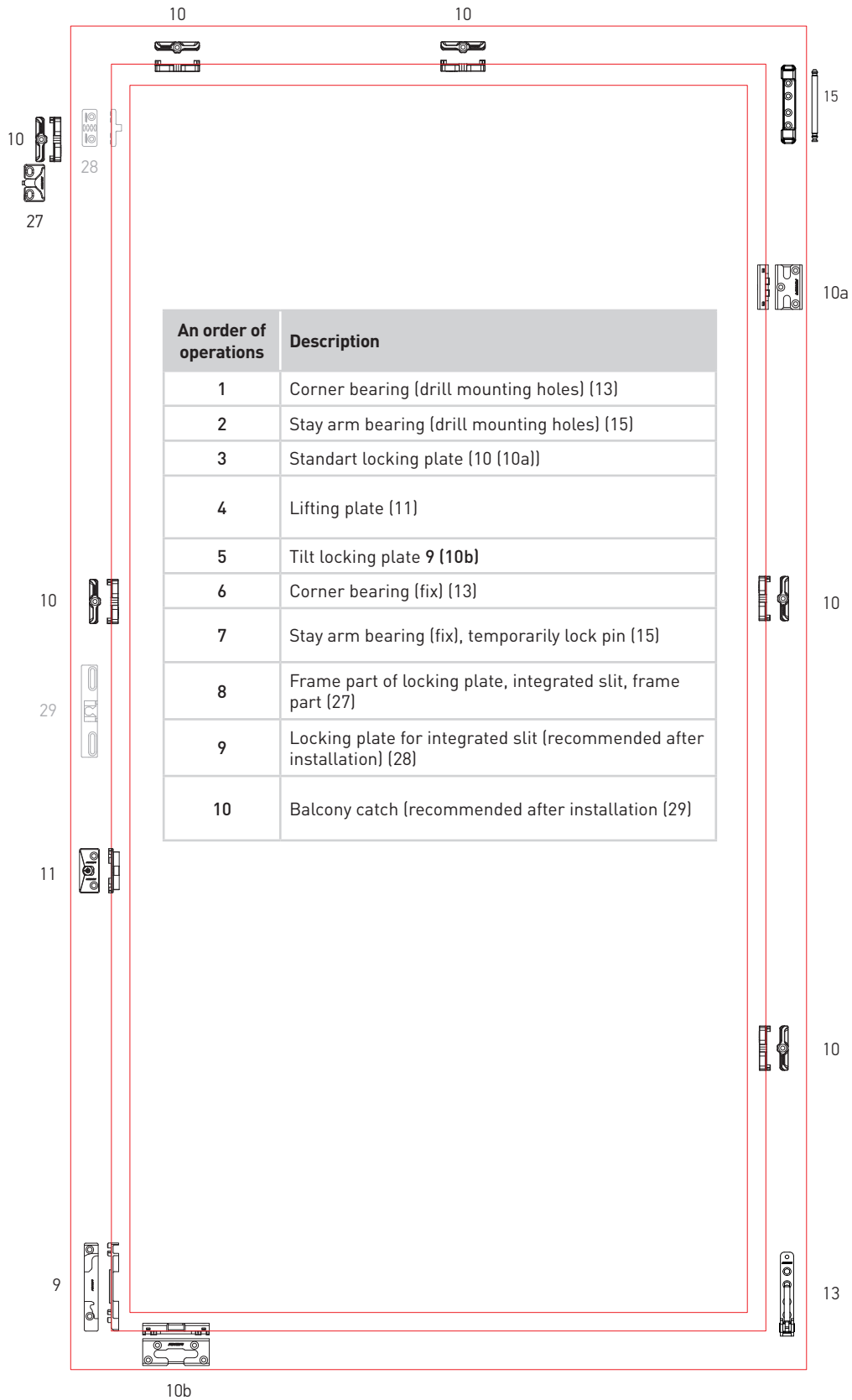

**AXOR**<sup>®</sup>

**KOMFORT LINE K-3**

Smart&Quick

Profile-dependent elements

AXOR





## Profile list

## Profile-dependent elements

Profile	B	Tilt locking plate	Locking plate	Lifting plate	Locking plate, integrated slit	Locking plate for adjustable integrated slit	Safety locking plate	Tilt safety locking plate	Tilt locking plate «First Tilt»	Locking plate adjustable for shoot bolt
ALUPLAST IDEAL 2000	13	K6004-13-L/R03	A7012-13-N03	A6003-13-N03	A6002-13-N03	A6004-00-N03	S6001-13-N03	S6002-13-N03	S6015-13-L/R03	K6002-13-N03
ALUPLAST IDEAL 4000	13	K6004-13-L/R03	A7012-13-N03	A6018-13-N03	A6002-13-N03	A6004-00-N03	S6023-13-N03	S6024-13-N03	S6034-13-L/R03	K6002-13-N03
ALUPLAST IDEAL 5000	13	K6004-13-L/R03	A7012-13-N03	A6018-13-N03	A6002-13-N03	A6004-00-N03	S6023-13-N03	S6024-13-N03	S6034-13-L/R03	K6002-13-N03
ALUPLAST IDEAL 8000	13	K6004-13-L/R03	A7012-13-N03	A6018-13-N03	A6002-13-N03	A6004-00-N03	S6023-13-N03	S6024-13-N03	S6034-13-L/R03	K6002-13-N03
BROKELMANN 58	13	K6001-13-L/R03	A7034-13-N00	A6003-13-N03	A6002-13-N03	A6004-00-N03	S6010-13-N03	S6011-13-N03	S6085-13-L/R03	K6002-13-N03
BROKELMANN 70	13	K6004-13-L/R03	A7012-13-N03	A6003-13-N03	A6002-13-N03	—	S6114-13-N03	S6115-13-N03	S6036-13-L/R03	K6002-13-N03
DECEUNINCK	13	K6008-13-L/R03	A7044-13-N03	A6010-13-N03	A6012-13-N03	A6045-13-N03	S6012-13-N03	S6013-13-N03	—	K6021-13-N03
DECEUNINCK EVEREST, ZENDOW, LEGEND	13	K6020-13-L/R03	A7153-13-N03	A6003-13-N03	A6002-13-N03	A6004-00-N03	S6112-13-N03	S6113-13-N03	S6066-13-L/R03	K6002-13-N03
GEALAN	13	K6009-13-L/R03	A7042-13-N03	A6003-13-N03	A6002-13-N03	A6004-00-N03	S6014-13-N03	S6022-13-L/R03	—	K6002-13-N03
GEALAN 9000N	13	—	A7066-13-N03	—	—	—	—	—	—	—
KBE 58/9	9	K6003-09-L/R03	A7013-09-N03	A6007-09-N03	A6005-09-N03	A6004-00-N03	S6003-09-N03	S6004-09-N03	S6047-09-L/R03	K6002-09-N03
KBE 58/9 Plus	9	K6003-09-L/R03	A7043-09-N03	A6007-09-N03	A6005-09-N03	A6004-00-N03	S6003-09-N03	S6004-09-N03	S6047-09-L/R03	K6002-09-N03
KBE 58/13	13	K6001-13-L/R03	A7011-13-N03	A6003-13-N03	A6002-13-N03	A6004-00-N03	S6010-13-N03	S6011-13-N03	S6068-13-L/R03	K6002-13-N03
KONING 70	13	K6004-13-L/R03	A7012-13-N03	A6003-13-N03	A6014-13-N03	—	S6114-13-N03	S6115-13-N03	S6036-13-L/R03	K6002-13-N03
MIROPLAST WDS 55	13	K6001-13-L/R03	A7011-13-N03	A6003-13-N03	A6002-13-N03	A6004-00-N03	S6001-13-N03	S6002-13-N03	S6015-13-L/R03	K6002-13-N03
MIROPLAST WDS 65	13	K6001-13-L/R03	A7011-13-N03	A6003-13-N03	A6002-13-N03	A6004-00-N03	S6001-13-N03	S6002-13-N03	S6015-13-L/R03	K6002-13-N03
MIROPLAST WDS 75	13	K6001-13-L/R03	A7011-13-N03	A6003-13-N03	A6002-13-N03	A6004-00-N03	S6001-13-N03	S6002-13-N03	S6015-13-L/R03	K6002-13-N03
MIROPLAST WDS 85	13	K6001-13-L/R03	A7011-13-N03	A6003-13-N03	A6002-13-N03	A6004-00-N03	S6001-13-N03	S6002-13-N03	S6015-13-L/R03	K6002-13-N03

B - sash groove position



## Profile list

## Profile-dependent elements

Profile	B	Tilt locking plate	Locking plate	Lifting plate	Locking plate, integrated slit	Locking plate for adjustable integrated slit	Safety locking plate	Tilt safety locking plate	Tilt locking plate «First Tilt»	Locking plate adjustable for shoot bolt
REHAU BASIC DESIGN	13	K6004-13-L/R03	A7012-13-N03	A6003-13-N03	A6002-13-N03	A6004-00-N03	S6136-13-N03	S6137-13-N03	S6098-13-L/R03	K6002-13-N03
"REHAU BRILLANT DESIGN, CLIMA DESIGN, THERMO DESIGN"	13	K6004-13-L/R03	A7012-13-N03	A6003-13-N03	A6002-13-N03	A6004-00-N03	S6136-13-N03	S6137-13-N03	S6098-13-L/R03	K6002-13-N03
REHAU SYNEGO	13	K6004-13-L/R03	A7012-13-N03	A6003-13-N03	A6002-13-N03	A6004-00-N03	S6136-13-N03	S6137-13-N03	S6098-13-L/R03	K6002-13-N03
SALAMANDER DESIGN 2D	13	K6004-13-L/R03	A7012-13-N03	A6013-13-N03	A6014-13-N03	—	S6136-13-N03	S6137-13-N03	S6098-13-L/R03	K6002-13-N03
SALAMANDER DESIGN 3D	13	K6004-13-L/R03	A7012-13-N03	A6013-13-N03	A6014-13-N03	—	S6136-13-N03	S6137-13-N03	S6098-13-L/R03	K6002-13-N03
VEKA SOFTLINE 58	13	K6001-13-L/R03	A7011-13-N03	A6003-13-N03	A6002-13-N03	A6004-00-N03	S6001-13-N03	S6002-13-N03	S6015-13-L/R03	K6002-13-N03
VEKA SOFTLINE 70	13	K6001-13-L/R03	A7011-13-N03	A6003-13-N03	A6002-13-N03	A6004-00-N03	S6001-13-N03	S6002-13-N03	S6015-13-L/R03	K6002-13-N03
VEKA TOPLINE AD	13	K6001-13-L/R03	A7011-13-N03	A6003-13-N03	A6002-13-N03	A6004-00-N03	S6001-13-N03	S6002-13-N03	S6015-13-L/R03	K6002-13-N03
VIKALAND B70	13	K6004-13-L/R03	A7012-13-N03	A6003-13-N03	A6014-13-N03	—	S6114-13-N03	S6115-13-N03	S6036-13-L/R03	K6002-13-N03
WINTECH 532 (ISOTECH)	13	K6001-13-L/R03	A7011-13-N03	A6017-13-N03	A6015-13-N03	A6016-00-N03	S6007-13-N03	S6008-13-N03	S6081-13-L/R03	K6002-13-N03
WINTECH 632	13	K6001-13-L/R03	A7011-13-N03	A6003-13-N03	A6002-13-N03	A6004-00-N03	S6001-13-N03	S6002-13-N03	S6015-13-L/R03	K6002-13-N03
WINTECH 742	13	K6001-13-L/R03	A7011-13-N03	A6003-13-N03	A6002-13-N03	A6004-00-N03	S6001-13-N03	S6002-13-N03	S6015-13-L/R03	K6002-13-N03
WINTECH 752	13	K6001-13-L/R03	A7011-13-N03	A6003-13-N03	A6002-13-N03	A6004-00-N03	S6001-13-N03	S6002-13-N03	S6015-13-L/R03	K6002-13-N03
WINTECH 80	13	K6001-13-L/R03	A7011-13-N03	A6003-13-N03	A6002-13-N03	A6004-00-N03	S6001-13-N03	S6002-13-N03	S6015-13-L/R03	K6002-13-N03
Double sash	—	—	A7063-00-N03	A6001-00-N03 A6046-00-N03	—	—	—	—	—	—

B - sash groove position



**Telescopic locking plate**

Profile-dependent elements

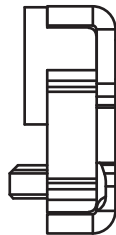
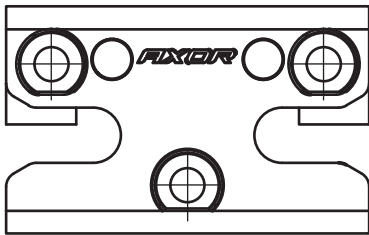
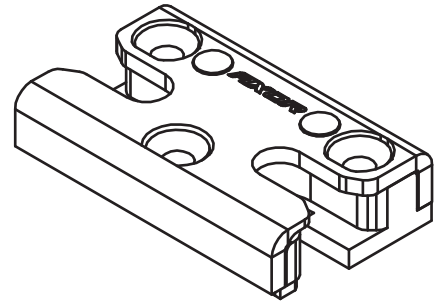
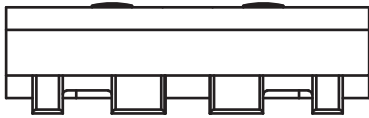

Description	Part No.
Telescopic locking plate 13 mm (WDS)	S6094-13-N03
Telescopic locking plate 13 mm (WINTECH 532)	S6095-13-N03
Telescopic locking plate 13 mm (KBE)	S6096-13-N03



**Tilt locking plates  
for aluminium doorstep**

Profile-dependent elements

S6102-13-N03

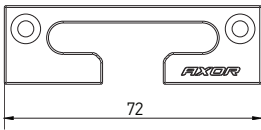
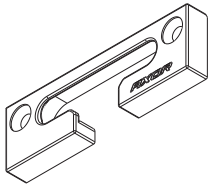

S6108-13-N03

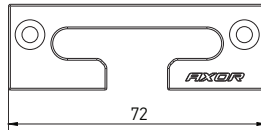
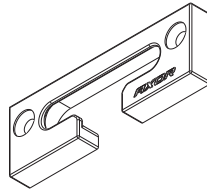

S6109-13-N03

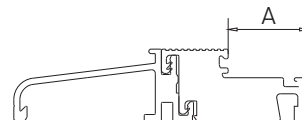
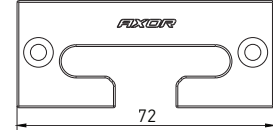
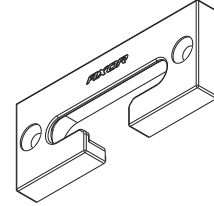

Description	A, mm	Part No.
Tilt safety locking plate, 13 mm, for aluminium doorstep, 22 mm	22	S6102-13-N03
Tilt safety locking plate, 13 mm, for aluminium doorstep, 24 mm	24	S6108-13-N03
Tilt safety locking plate, 13 mm, for aluminium doorstep, 30 mm	30	S6109-13-N03



**Frame part of sash lifter**

Profile-dependent elements

Frame part of sash lifter

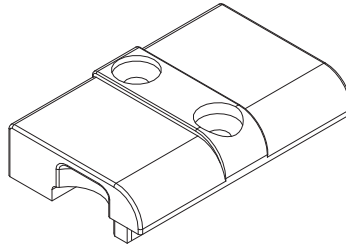
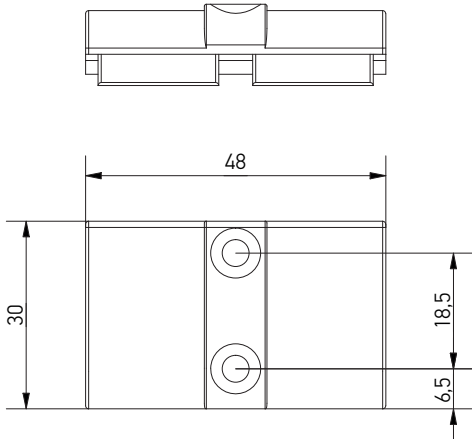

The frame part is compatible with WDS, VEKA, ALUPLAST 2000, VIKNALAND, SONAROL.

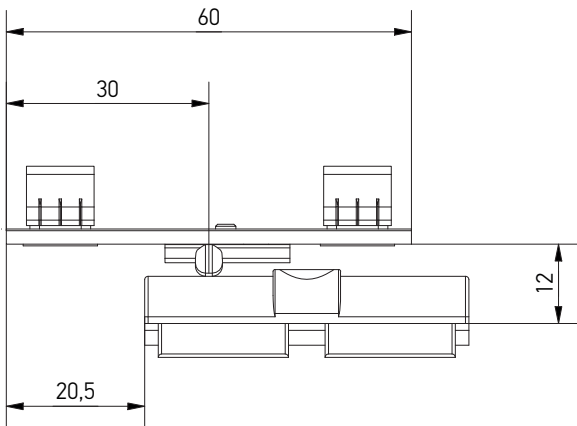

The single sash lifter A7236-00-N03 use together with the suitable frame part A7237-XX-N03.

The single sash lifter (A7236-01-N03) can be found on p. 132.

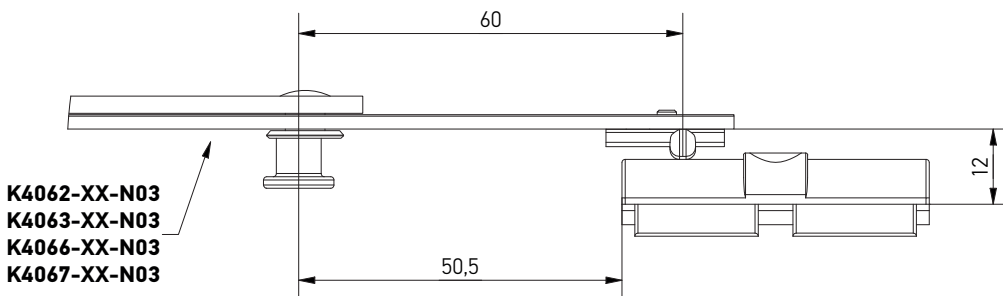

The extension locks K4062-XX-N03, K4063-XX-N03, K4066-XX-N03, K4067-XX-N03 use together with the suitable frame part A7237-XX-N03.

The extension locks can be found in the Section 3 "Corner transmissions / Middle locks".

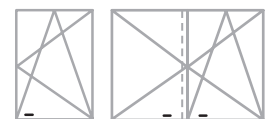

Description	Dimensions			Part No.
-------------	------------	--	--	----------

Frame part of sash lifter	48	2	100	A7237-01-N03
---------------------------	----	---	-----	--------------



AXOR INDUSTRY  
32, Pratsi Avenue,  
Dnipro, 49041, Ukraine.  
[www.axorindustry.com](http://www.axorindustry.com)