

AXOR[®]

INTENT

Hardware for sliding systems



www.axorindustry.com



Content

■ SMART GLIDE TECH

1.1 Introduction.....	4
1.2 Hardware sets	10
1.3 Smart Glide Tech system elements.....	25
1.4 Perimeter strapping elements	31
1.5 Installation, adjustments, jigs	41

AXOR[®]



SECTION 1

INTENT  **SMART GT**

**SLIDING SYSTEM
OF THE NEW GENERATION**



SMART GLIDE TECH system

AXOR Intent Smart Glide Tech is ideal for large PVC constructions because, unlike lift-and-slide system, you don't need to lift the sash to move it. The system is arranged in such a way that when the handle is lifted up, the sash independently moves away from the frame by 6 mm, after which a light push to the side is enough for the sash weighing up to 200 kg to open smoothly. There is no need to lift a heavy structure for sliding, and friction during closing is minimized, so that no

extra effort is required to operate the system. Such hardware are best fitted for open facades and winter gardens, as they are highly airtight and provide easy opening of large and heavy sashes.

AXOR Intent Smart Glide Tech hardware allow the production of PVC structures with a width of up to 1790 mm and a height of up to 2390 mm. In addition, it provides high thermal insulation and waterproofing.



Side lock + locking plate

The main locking element from the mullion side.



Running mechanism (bogie) with built-in ball bearings for better gliding.

Comfortable



AXOR Intent Smart Glide Tech combines smooth movement with intuitive control. Thanks to the running mechanisms (bogies), the movement of even large and heavy sashes is extremely smooth and easy. Built-in ball bearings minimize friction, which ensures easy and reliable operation of the system. In addition, it provides high thermal insulation and waterproofing.

Impermeable



A continuous sealing circuit and a large number of pressure points guarantee maximum tightness of the system. Closed, the system reliably protects against street noise, torrential rain and gale force winds. This makes it ideal for high-rise buildings, open terraces and winter gardens.

Secure



AXOR Intent Smart Glide Tech reliably protects premises from thieves. The structure, equipped with mushroom locking pins paired with security locking plates, ensures a consistently high break-resistance of windows and doors.



The principle of opening structures

The sash is closed

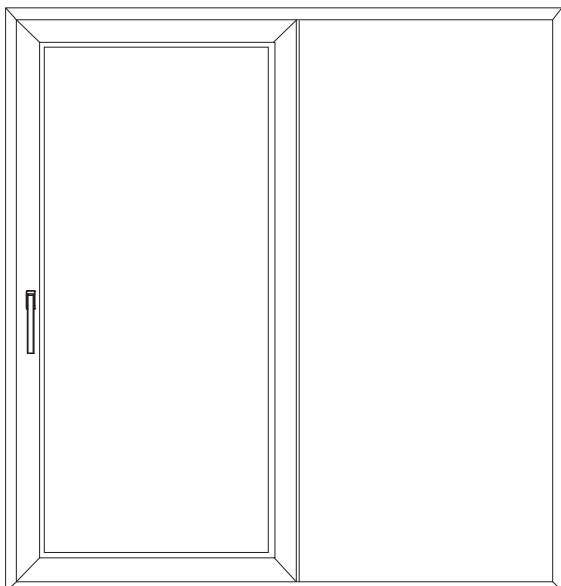

The sash is opened

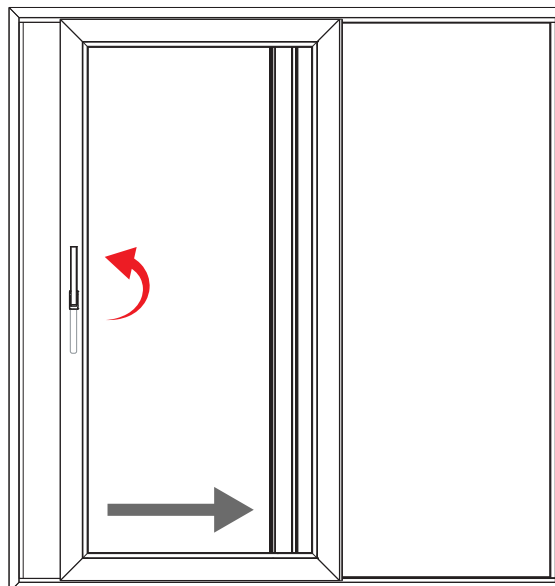

When the handle is lifted up, the sash moves away from the frame by 6 mm, after which it can be pushed to the side.

Direction of structures opening

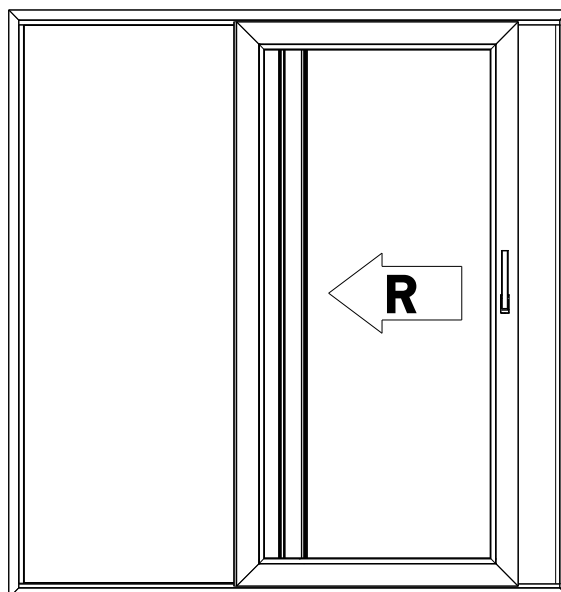
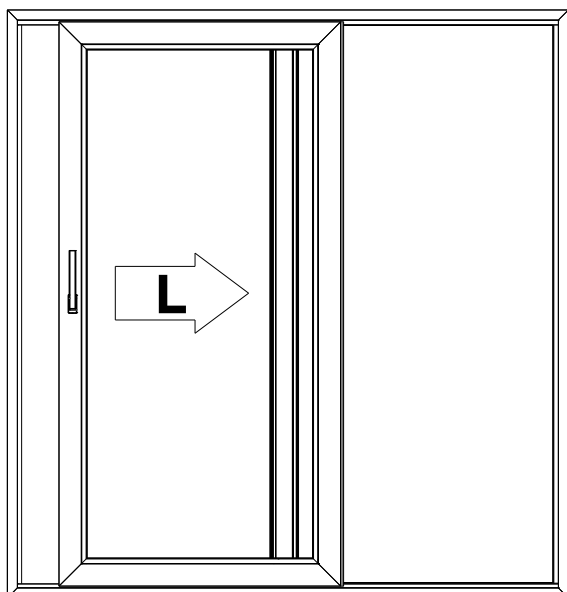



Application range diagram

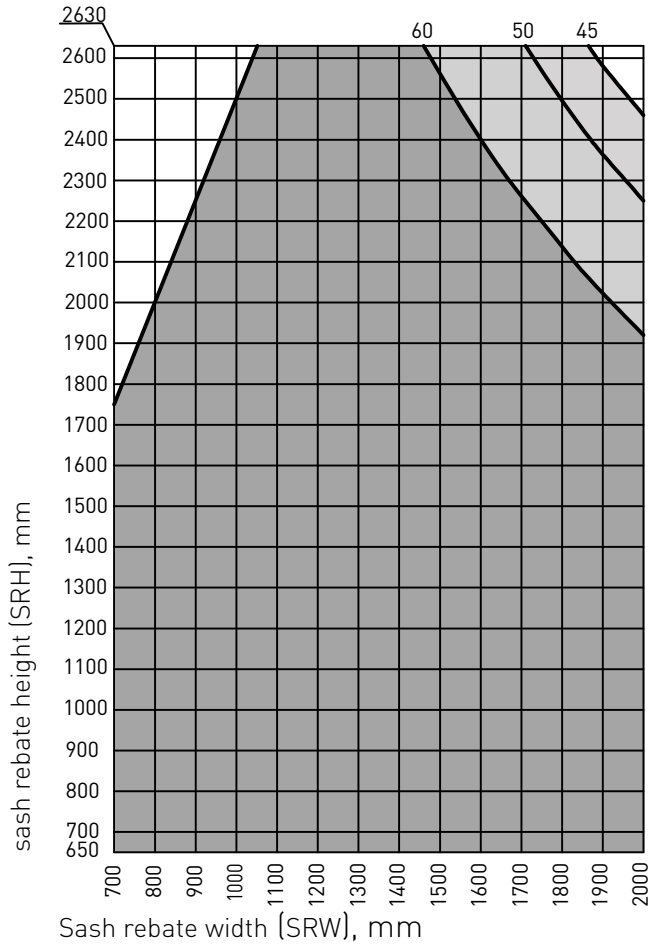

Correlation SRH:SRW = max 2,5:1
The maximum sash weight is up to 250 kg

- 45 kg – weight per m² of a sash
- 50 kg – weight per m² of a sash
- 60 kg – weight per m² of a sash

The permitted application range for AXOR hardware is marked in gray in the diagrams. This does not apply to the entire gray area, but only to the portion to the left of the curve for a given weight.

SRH - sash rebate height
 SRW - sash rebate width

SPECIFICATIONS		
The weight of the sash	250 kg	
Sash rebate width (SRW)	(700*) 800-1790 mm	Correlation SRH:SRW = max 2.5:1
Sash rebate height (SRH)	650-2630 mm	
Profiles	WDS 76 SL Aluplast Smart-Slide Aluplast neo REHAU Synego (Intelio) Slide Gealan Smoovio Decco Slide Framex Veratec	

* special middle connection

**from 650 mm according to scheme 1; from 810 mm according to scheme 2.

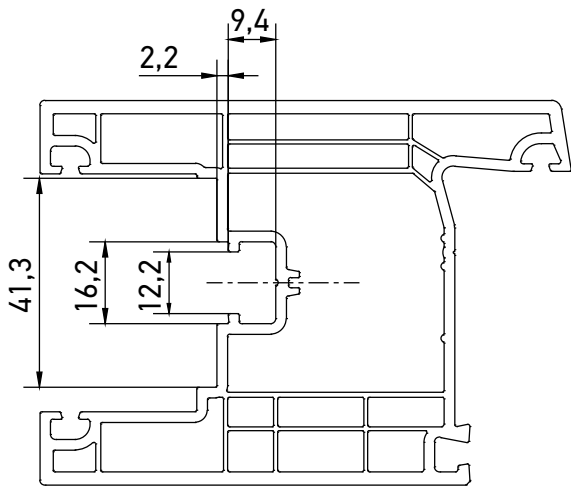
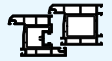

SRW
(including sash adapter)

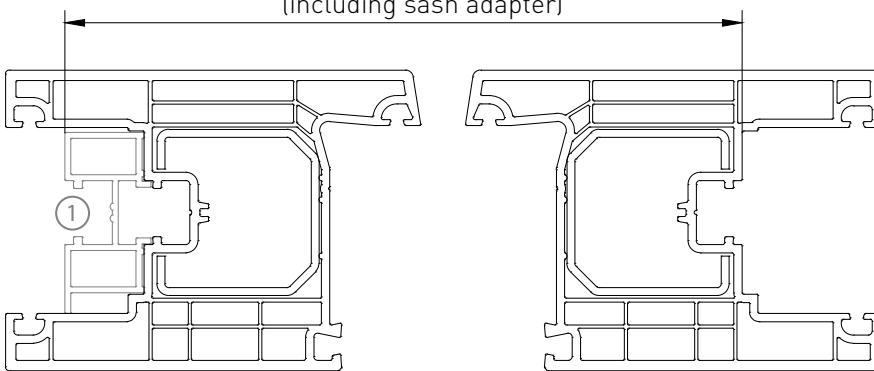

1 - sash adapter

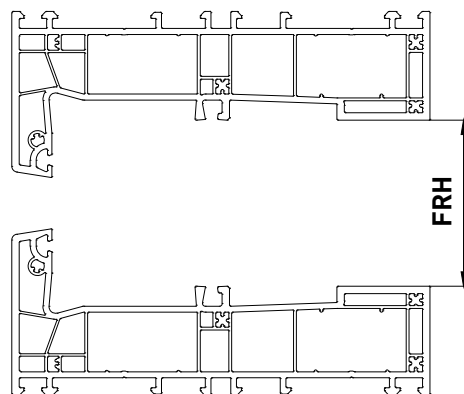
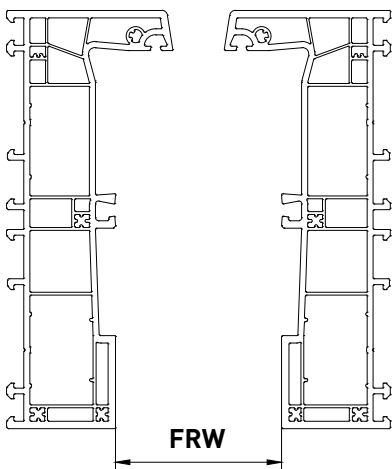
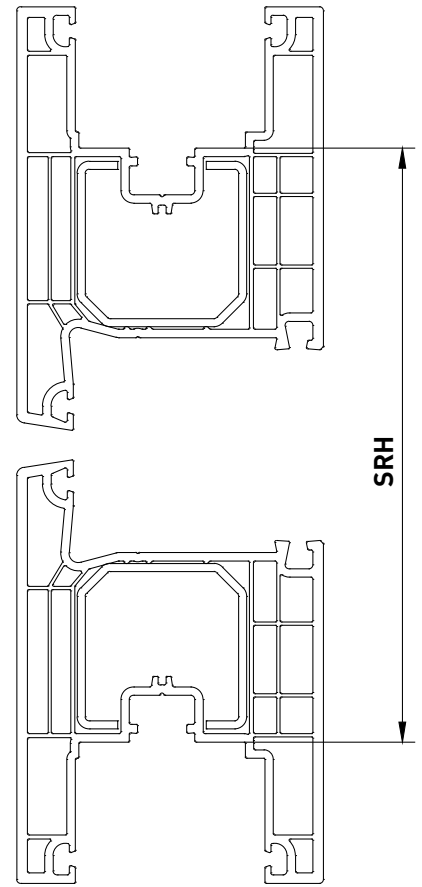

SRH - sash rebate height
 SRW - sash rebate width
 FRH - frame rebate height
 FRW - frame rebate width

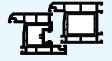
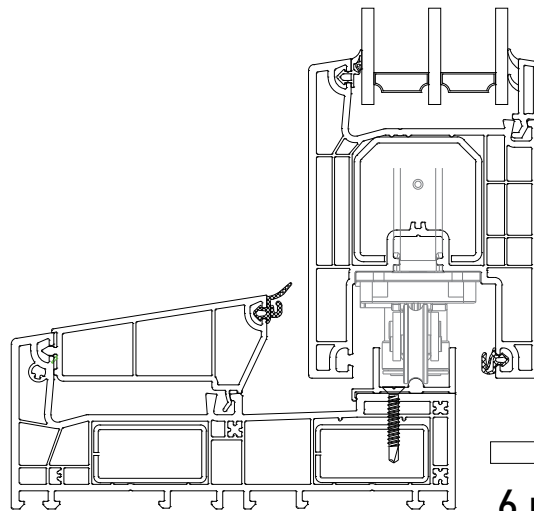
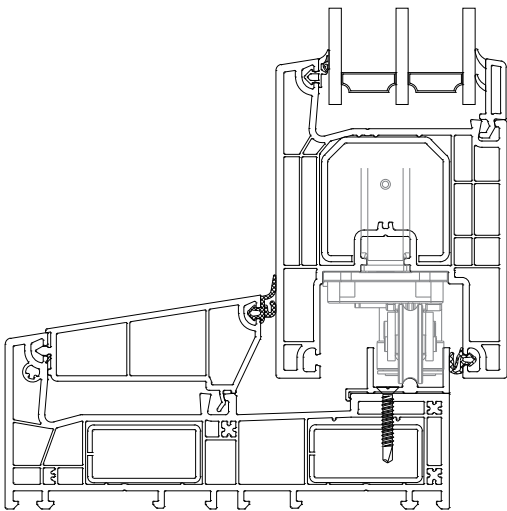
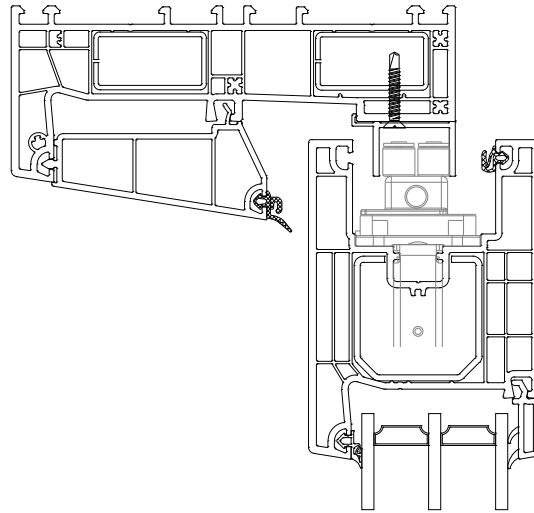
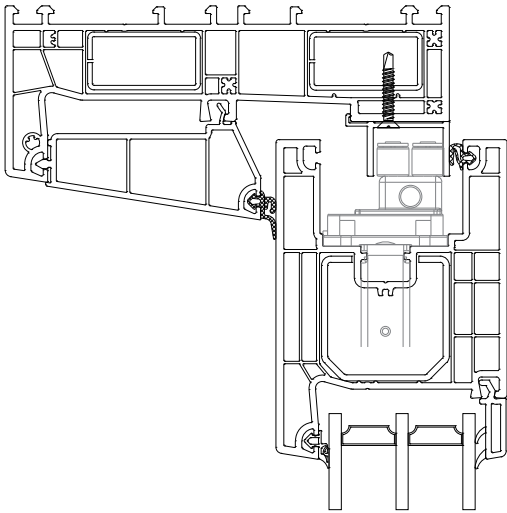
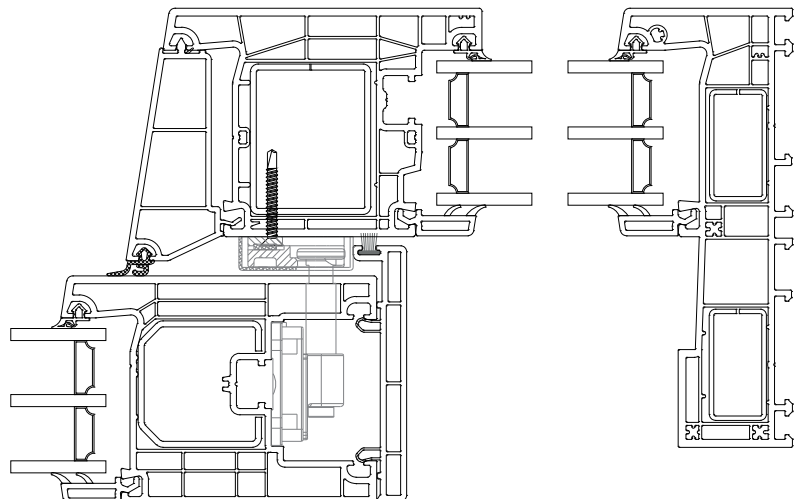
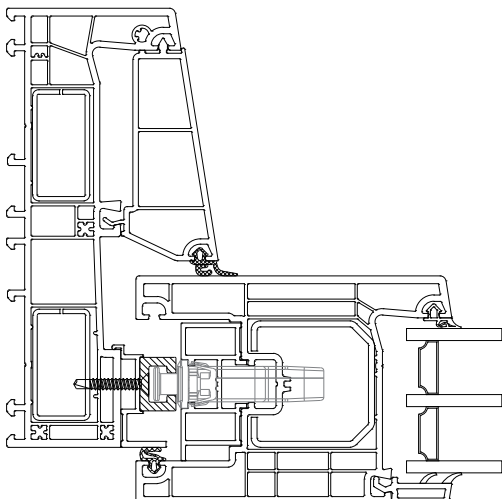
**Vertical cross-section****Close****Open**→
6 mm**Horizontal cross-section**

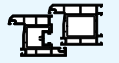

Drilling and milling a sash for 35-mm backset gear

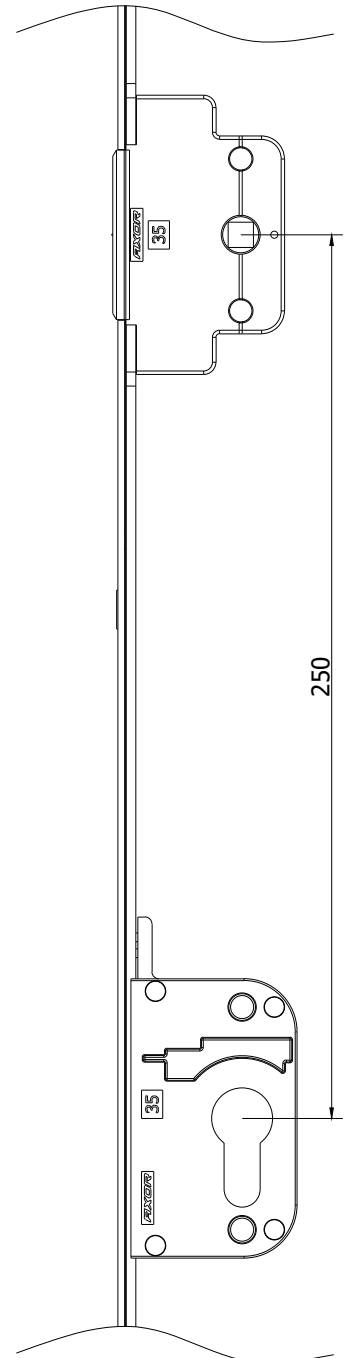
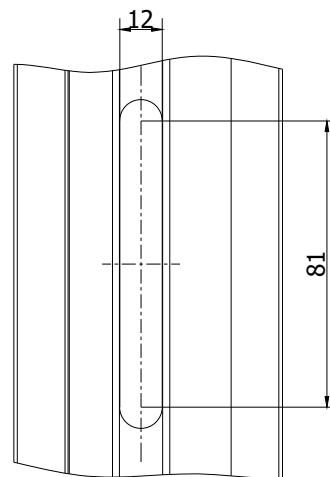
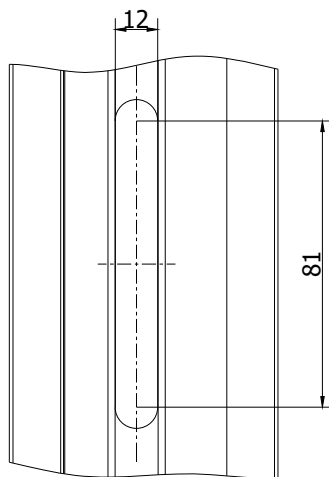
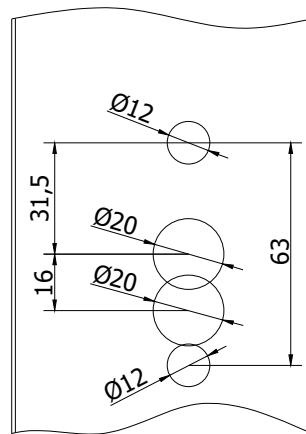
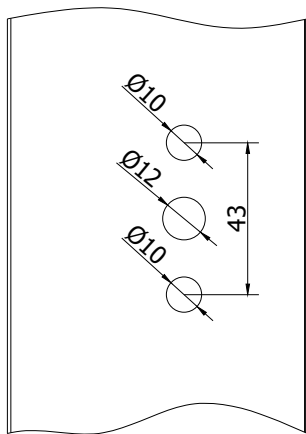
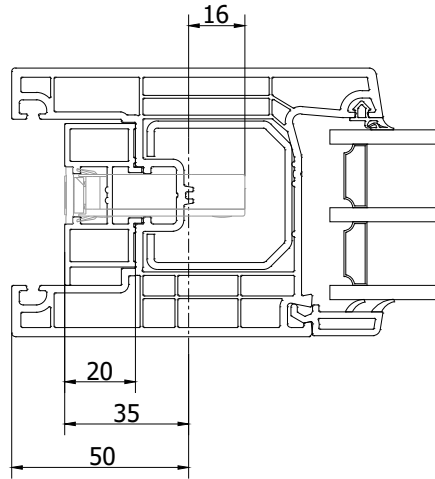
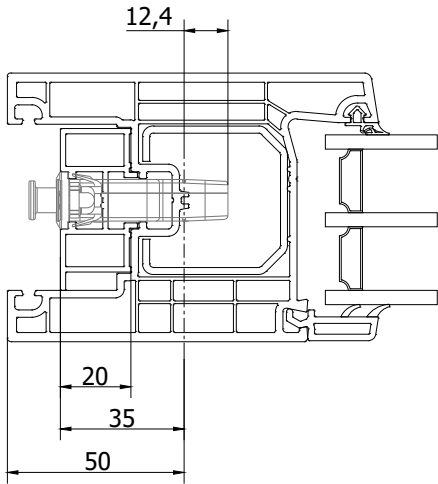



SMART GLIDE TECH hardware set - Scheme 1 (position of the handle in the center*)

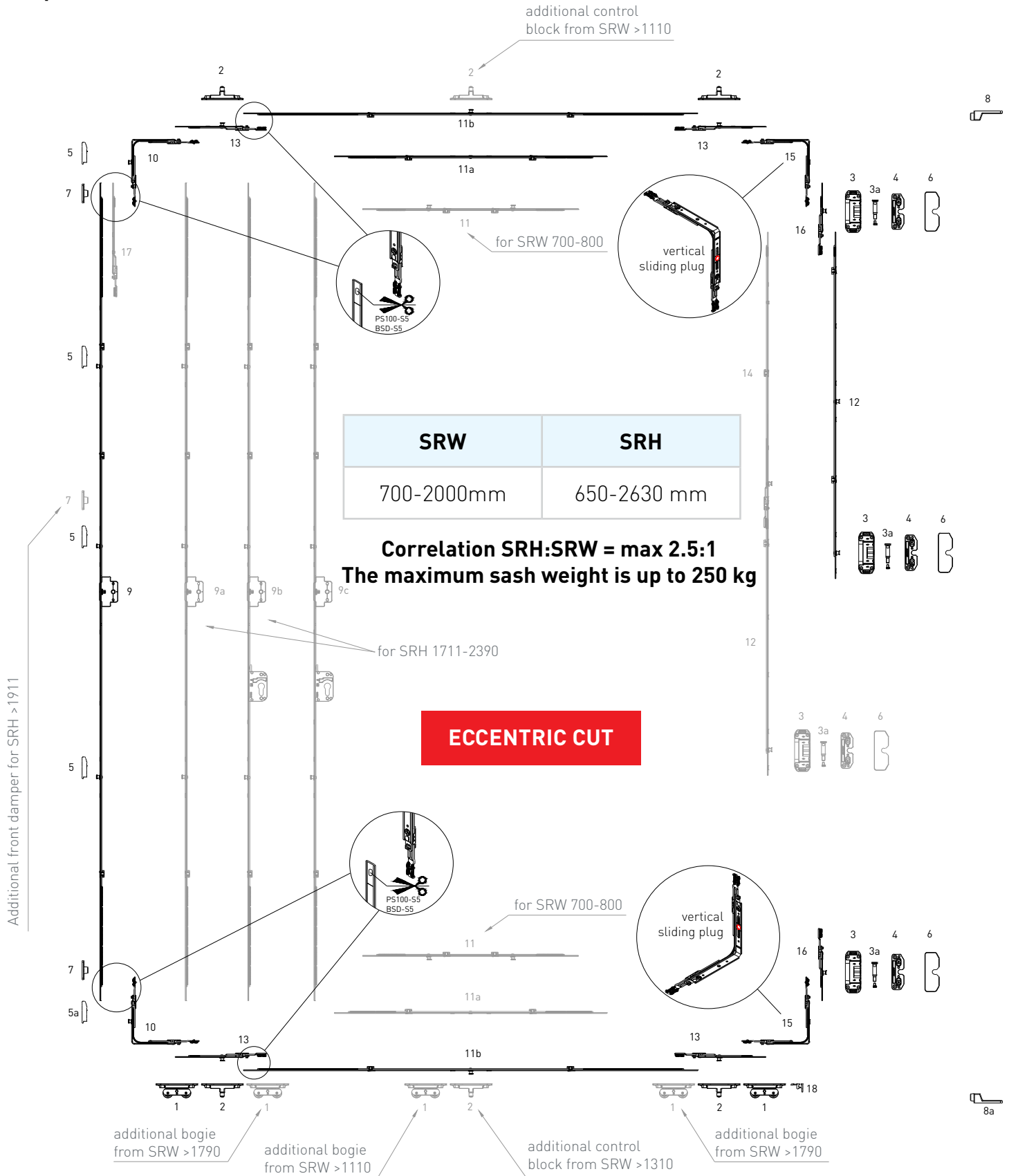

* for application range 2391-2630, the handle is offset downwards by 1-240 mm



SMART GLIDE TECH hardware set - Scheme 1 (position of the handle in the center*)

	№	Part number	Description	WIDTH					
				700-800	801-910	911-1110	1111-1310	1311-1790	1791-2000
Main set	1	I7006-00-N03	Bogie	2	2	2	3	3	5
	2	I7007-00-L03/R03	Control block, left / right	4	4	4	5	6	6
	10	K2025-00-N03	Corner transmission, 115x115, 1 MR	2	2	2	2	2	2
	15	K2036-00-N03	Corner transmission, 115x115, without ML	2	2	2	2	2	2
	16	K4050-00-N03	Extension lock 130 mm, 1 MR	2	2	2	3	2	2
	8	I7010-**-N03	Opened position stopper	1	1	1	1	1	1
	8a	I7010-01-N03	Opened position stopper (lower)	1	1	1	1	1	1
	18	I7014-01-N03	Anti-tilt device	1	1	1	1	1	1
Horizontal extension locks	13	K4050-01-N03	Extension lock 180 mm, 1 MR	0	4	4	4	4	4
	11	K4069-06-N03	Middle connection, sliding system, L = 570, 700-800, 2 MR	2	0	0	0	0	0
	11a	K4068-03-N03	Middle connection, L = 320, without ML	0	2	0	0	0	0
		K4068-05-N03	Middle connection, L = 520, without ML	0	0	2	0	0	0
		K4068-07-N03	Middle connection, L = 720, without ML	0	0	0	1	0	0
	11b	K4033-07-N03	Middle connection, L = 720, 1 MR	0	0	0	1	0	0
K4033-11-N03		Middle connection, L = 1200, 1 MR	0	0	0	0	2	0	
K4033-17-N03		Middle connection, L = 1680, 1 MR	0	0	0	0	0	2	
HEIGHT 650-750	9	K1054-04-N03	Gear variable L=520, 551-750, backset 35 mm	1	1	1	1	1	1
	3	I7018-**-L03/R03	Side lock, left / right	2	2	2	2	2	2
	3a	I6001-**-N03	Central bolt of the side lock	2	2	2	2	2	2
	4	I7009-00-N03	Side locking plate	2	2	2	2	2	2
	6	I7100-00-N0***	Cover of side locking plate, sliding system	2	2	2	2	2	2
	5	I7012-00-N03	Locking plate for sliding system	1	1	1	1	1	1
	5a	I7017-00-N03	Locking plate for sliding system, incorrect operation device	1	1	1	1	1	1
	7	I7011-00-N03	Front damper	2	2	2	2	2	2
HEIGHT 751-1200	9	K1054-09-N03	Gear variable L=1000, 751-1230, 1 MR, backset 35 mm	1	1	1	1	1	1
	3	I7018-00-L03/R03	Side lock, left / right	2	2	2	2	2	2
	3a	I6001-**-N03	Central bolt of the side lock	2	2	2	2	2	2
	4	I7009-00-N03	Side locking plate	2	2	2	2	2	2
	6	I7100-00-N0***	Cover of side locking plate, sliding system	2	2	2	2	2	2
	5	I7012-00-N03	Locking plate for sliding system	2	2	2	2	2	2
	5a	I7017-00-N03	Locking plate for sliding system, incorrect operation device	1	1	1	1	1	1
	7	I7011-00-N03	Front damper	2	2	2	2	2	2



		WIDTH							
HEIGHT	№	Part number	Description	700-800	801-910	911-1110	1111-1310	1311-1790	1791-2000
				1201-1430	9	K1054-11-N03	Gear variable L=1200, 950-1430, 1 MR, backset 35 mm	1	1
3	I7018-**-L03/R03	Side lock, left/right	3		3	3	3	3	3
3a	I6001-**-N03	Central bolt of the side lock	3		3	3	3	3	3
4	I7009-00-N03	Side locking plate	3		3	3	3	3	3
6	I7100-00-N03	Cover of side locking plate, sliding system	3		3	3	3	3	3
5	I7012-00-N03	Locking plate for sliding system	2		2	2	2	2	2
5a	I7017-00-N03	Locking plate for sliding system, incorrect operation device	1		1	1	1	1	1
7	I7011-00-N03	Front damper	2		2	2	2	2	2
12	K4054-05-N03	Extension lock 480 mm, 1 MR	1		1	1	1	1	1
1431-1710	9	K1054-14-N03	Gear variable L=1480, 1231-1710, 2 MR, backset 35 mm	1	1	1	1	1	1
	3	I7018-**-L03/R03	Side lock, left/right	3	3	3	3	3	3
	3a	I6001-**-N03	Central bolt of the side lock	3	3	3	3	3	3
	4	I7009-00-N03	Side locking plate	3	3	3	3	3	3
	6	I7100-00-N03	Cover of side locking plate, sliding system	3	3	3	3	3	3
	5	I7012-00-N03	Locking plate for sliding system	3	3	3	3	3	3
	5a	I7017-00-N03	Locking plate for sliding system, incorrect operation device	1	1	1	1	1	1
	7	I7011-00-N03	Front damper	2	2	2	2	2	2
	12	K4054-05-N03	Extension lock L=480, 1 MR	1	1	1	1	1	1
1711-1910	9	K1054-16-N03	Gear variable L=1680, 1431-1910, 2 MR, backset 35 mm	1	1	1	1	1	1
	9a	K1094-16-N03	Gear variable L=1680, 1431-1910, 2 MR, backset 35 mm, 2-side handle	1	1	1	1	1	1
	9b	K1095-16-N03	Gear variable L=1680, 1431-1910, 2 MR, backset 35 mm, 3 PZ=250 mm	1	1	1	1	1	1
	9c	K1096-16-N03	Gear variable L=1680, 1431-1910, 2 MR, backset 35 mm, 3 PZ=250 mm, 2-side handle	1	1	1	1	1	1
	3	I7018-**-L03/R03	Side lock, left/right	3	3	3	3	3	3
	3a	I6001-**-N03	Central bolt of the side lock	3	3	3	3	3	3
	4	I7009-00-N03	Side locking plate	3	3	3	3	3	3
	6	I7100-00-N03	Cover of side locking plate, sliding system	3	3	3	3	3	3
	5	I7012-00-N03	Locking plate for sliding system	3	3	3	3	3	3
	5a	I7017-00-N03	Locking plate for sliding system, incorrect operation device	1	1	1	1	1	1
	7	I7011-00-N03	Front damper	2	2	2	2	2	2
	12	K4054-07-N03	Extension lock L=680, 1 MR	1	1	1	1	1	1

		WIDTH							
		700-800	801-910	911-1110	1111-1310	1311-1790	1791-2000		
HEIGHT	Nº	Part number	Description						
1911-2110	9	K1054-21-N03	Gear variable L=2160, 1911-2390, 3 MR, backset 35 mm	1	1	1	1	1	1
	9a	K1094-21-N03	Gear variable L=2160, 1911-2390, 3 MR, backset 35 mm, 2-side handle	1	1	1	1	1	1
	9b	K1095-21-N03	Gear variable L=2160, 1911-2390, 3 MR, backset 35 mm, 3 PZ=250 mm	1	1	1	1	1	1
	9c	K1096-21-N03	Gear variable L=2160, 1911-2390, 3 MR, backset 35 mm, 3 PZ=250 mm 2-side handle	1	1	1	1	1	1
	3	I7018-**-L03/R03	Side lock, left/right	3	3	3	3	3	3
	3a	I6001-**-N03	Central bolt of the side lock	3	3	3	3	3	3
	4	I7009-00-N03	Side locking plate	3	3	3	3	3	3
	6	I7100-00-N0***	Cover of side locking plate, sliding system	3	3	3	3	3	3
	5	I7012-00-N03	Locking plate for sliding system	4	4	4	4	4	4
	5a	I7017-00-N03	Locking plate for sliding system, incorrect operation device	1	1	1	1	1	1
	5	I7012-00-N03	Locking plate, sliding system	5	5	5	5	5	5
	7	I7011-00-N03	Front damper	3	3	3	3	3	3
	12	K4054-09-N03	Extension lock L=880, 2 MR	1	1	1	1	1	1
	2111-2390	9	K1054-21-N03	Gear variable L=2160, 1911-2390, 3 MR, backset 35 mm	-	1	1	1	1
9a		K1094-21-N03	Gear variable L=2160, 1911-2390, 3 MR, backset 35 mm, 2-side handle	-	1	1	1	1	1
9b		K1095-21-N03	Gear variable L=2160, 1911-2390, 3 MR, backset 35 mm, PZ=250 mm	-	1	1	1	1	1
9c		K1096-21-N03	Gear variable L=2160, 1911-2390, 3 MR, backset 35 mm, 3 PZ=250 mm 2-side handle	-	1	1	1	1	1
3		I7018-**-L03/R03	Side lock, left/right	-	4	4	4	4	4
3a		I6001-**-N03	Central bolt of the side lock	-	4	4	4	4	4
4		I7009-00-N03	Side locking plate	-	4	4	4	4	4
6		I7100-00-N***	Cover of side locking plate, sliding system	-	4	4	4	4	4
5		I7012-00-N03	Locking plate for sliding system	-	4	4	4	4	4
5a		I7017-00-N03	Locking plate for sliding system, incorrect operation device	-	1	1	1	1	1
7		I7011-00-N03	Front damper	-	3	3	3	3	3
12		K4054-05-N03	Extension lock L=480, 1 MR	-	1	1	1	1	1
14		K4071-07-N03	Extension lock L=720, 1 MR, without possibility to cut	-	1	1	1	1	1



№	Part number	Description	WIDTH						
			700-800	801-910	911-1110	1111-1310	1311-1790	1791-2000	
2391-2630	9	K1054-21-N03	Gear variable L=2160, 1911-2390, 3 MR, backset 35 mm	-	-	1	1	1	1
	9a	K1094-21-N03	Gear variable L=2160, 1911-2390, 3 MR, backset 35 mm, 2-side handle	-	-	1	1	1	1
	9b	K1095-21-N03	Gear variable L=2160, 1911-2390, 3 MR, backset 35 mm, PZ=250 mm	-	-	1	1	1	1
	9c	K1096-21-N03	Gear variable L=2160, 1911-2390, 3 MR, backset 35 mm, 3 PZ=250 mm 2-side handle	-	-	1	1	1	1
	17	K4057-02-N03	Extension lock L=240, without ML	-	-	1	1	1	1
	3	I7018-**-L03/R03	Side lock, left/right	-	-	4	4	4	4
	3a	I6001-**-N03	Central bolt of the side lock	-	-	4	4	4	4
	4	I7009-00-N03	Side locking plate	-	-	4	4	4	4
	6	I7100-00-N***	Cover of side locking plate, sliding system	-	-	4	4	4	4
	5	I7012-00-N03	Locking plate for sliding system	-	-	4	4	4	4
	5a	I7017-00-N03	Locking plate for sliding system, incorrect operation device	-	-	1	1	1	1
	7	I7011-00-N03	Front damper	-	-	3	3	3	3
	12	K4054-05-N03	Extension lock L=480, 1 MR	-	-	1	1	1	1
	14	K4071-07-N03	Extension lock L=720, 1 MR, without possibility to cut	-	-	1	1	1	1

* for application range 2391-2630, the handle is offset downwards by 1-240 mm

** profile-depending elements

*** color: N01 - white RAL9016
 N02 - brown RAL8022
 N03 - silver
 N05 - golden
 N06 - bronze
 N07 - black RAL9005
 N09 - anthracite gray RAL7016

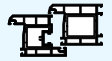

**SMART GLIDE TECH hardware set - Scheme 1
(handle position G=1000)**

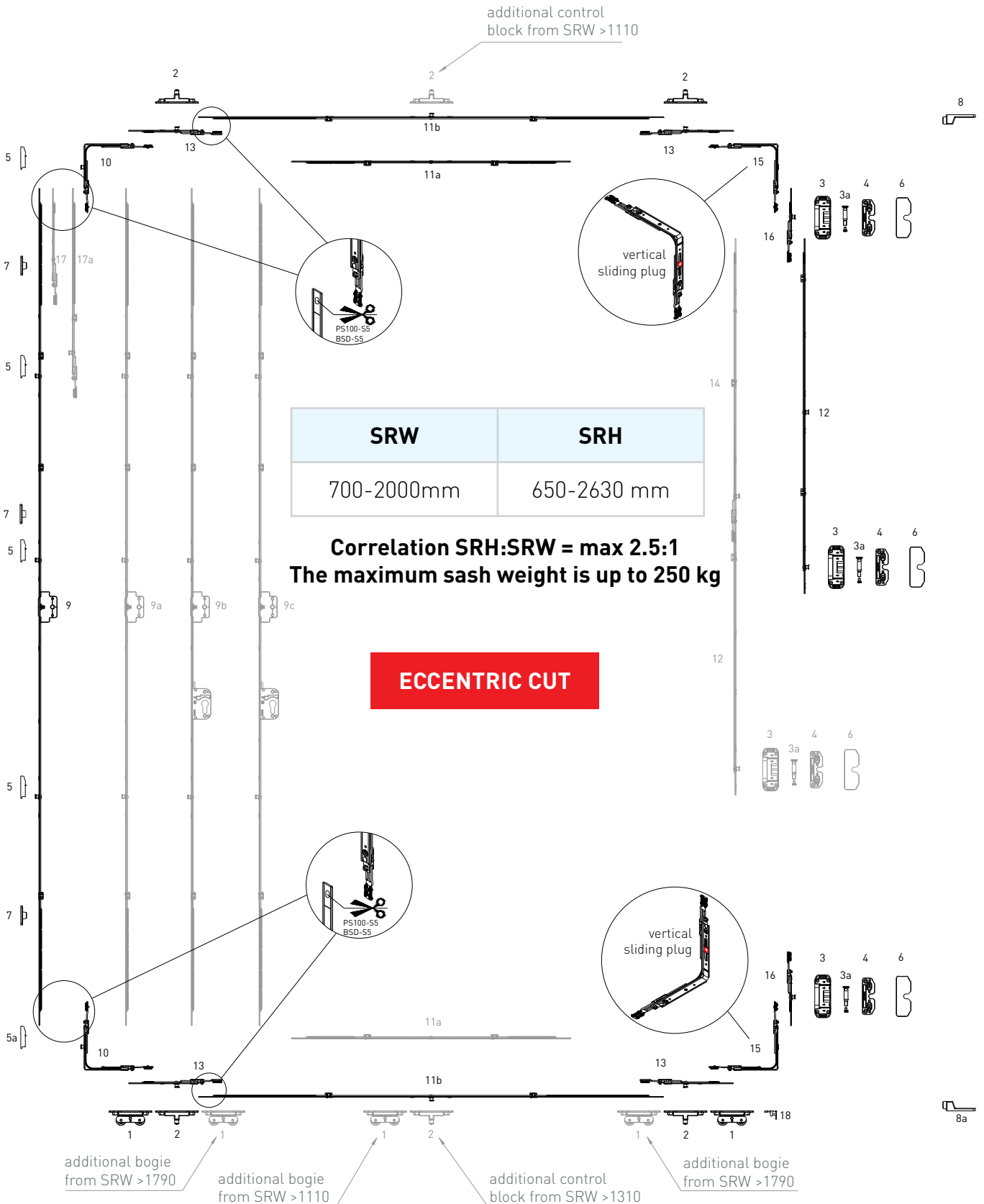



SMART GLIDE TECH hardware set - Scheme 1 (handle position G=1000)

	N°	Part number	Description	WIDTH							
				800-910	911-1110	1111-1310	1311-1790	1791-2000			
Main set	1	I7006-00-N03	Bogie	2	2	3	3	5			
	2	I7007-00-L03/R03	Control block, left / right	4	4	5	6	6			
	10	K2025-00-N03	Corner transmission, 115x115, 1 MR	2	2	2	2	2			
	15	K2036-00-N03	Corner transmission, 115x115, without ML	2	2	2	2	2			
	16	K4050-00-N03	Extension lock 130 mm, 1 MR	2	2	2	2	2			
	8	I7010-**-N03	Opened position stopper	1	1	1	1	1			
	8a	I7010-01-N03	Opened position stopper (lower)	1	1	1	1	1			
	18	I7014-00-N03	Incorrect operation device	1	1	1	1	1			
Horizontal extension locks	13	K4050-01-N03	Extension lock 180 mm, 1 MR	4	4	4	4	4			
	11a	K4068-03-N03	Middle connection, L = 320, without ML	2	0	0	0	0			
		K4068-05-N03	Middle connection, L = 520, without ML	0	2	0	0	0			
		K4068-07-N03	Middle connection, L = 720, without ML	0	0	1	0	0			
	11b	K4033-07-N03	Middle connection, L = 720, 1 MR	0	0	1	0	0			
		K4033-11-N03	Middle connection, L = 1200, 1 MR	0	0	0	2	0			
HEIGHT	2000-2195	9	K1054-21-N03	Gear variable L=2160, 1911-2390, 3 MR, backset 35 mm	1	1	1	1	1		
			9a	K1094-21-N03	Gear variable L=2160, 1911-2390, 3 MR, backset 35 mm, 2-side handle	1	1	1	1	1	
			9b	K1095-21-N03	Gear variable L=2160, 1911-2390, 3 MR, backset 35 mm, PZ=250 mm	1	1	1	1	1	
		9c	K1096-21-N03	Gear variable L=2160, 1911-2390, 3 MR, backset 35 mm, PZ=250 mm, 2-side handle	1	1	1	1	1		
		3	I7018-**-L03/R03	Side lock, left / right	3	3	3	3	3		
		3a	I6001-**-N03	Central bolt of the side lock	3	3	3	3	3		
		4	I7009-00-N03	Side locking plate	3	3	3	3	3		
		6	I7100-00-N***	Cover of side locking plate, sliding system	3	3	3	3	3		
		5	I7012-00-N03	Locking plate for sliding system	4	4	4	4	4		
	5a	I7017-00-N03	Locking plate for sliding system, incorrect operation device	1	1	1	1	1			
	5	I7012-00-N03	Locking plate, sliding system	5	5	5	5	5			
	7	I7011-00-N03	Front damper	3	3	3	3	3			
	12	K4054-09-N03	Extension lock	1	1	1	1	1			
	2196-2390	9	K1054-21-N03	Gear variable L=2160, 1911-2390, 3 MR, backset 35 mm	1	1	1	1	1		
					9a	K1094-21-N03	Gear variable L=2160, 1911-2390, 3 MR, backset 35 mm, 2-side handle	1	1	1	1
9b					K1095-21-N03	Gear variable L=2160, 1911-2390, 3 MR, backset 35 mm, PZ=250 mm	1	1	1	1	1
9c		K1096-21-N03	Gear variable L=2160, 1911-2390, 3 MR, backset 35 mm, PZ=250 mm, 2-side handle	1	1	1	1	1			
17		K4057-02-N03	Extension lock L=240, without ML	1	1	1	1	1			
3		I7018-**-L03/R03	Side lock, left / right	4	4	4	4	4			
3a	I6001-**-N03	Central bolt of the side lock	4	4	4	4	4				



					WIDTH				
		Nº	Part number	Description	800-910	911-1110	1111-1310	1311-1790	1791-2000
HEIGHT	2196-2390	4	I7009-00-N03	Side locking plate	4	4	4	4	4
		6	I7100-00-N***	Cover of side locking plate, sliding system	4	4	4	4	4
		5	I7012-00-N03	Locking plate for sliding system	4	4	4	4	4
		5a	I7017-00-N03	Locking plate for sliding system, incorrect operation device	1	1	1	1	1
		7	I7011-00-N03	Front damper	3	3	3	3	3
		12	K4054-05-N03	Extension lockfor corner transmission 480 mm, 1 MR	1	1	1	1	1
		14	K4071-07-N03	Extension lockL=720, 1 MR, without possibility to cut	1	1	1	1	1
	2391-2630	9	K1054-21-N03	Gear variable L=2160, 1911-2390, 3 MR, backset 35 mm	-	1	1	1	1
		9a	K1094-21-N03	Gear variable L=2160, 1911-2390, 3 MR, backset 35 mm, 2-side handle	-	1	1	1	1
		9b	K1095-21-N03	Gear variable L=2160, 1911-2390, 3 MR, backset 35 mm, PZ=250 mm	-	1	1	1	1
		9c	K1096-21-N03	Gear variable L=2160, 1911-2390, 3 MR, backset 35 mm, PZ=250 mm, 2-side handle	-	1	1	1	1
		17a	K4050-05-N03	Extension lock 480 mm, 1 MR	-	1	1	1	1
		3	I7018-**-L03/R03	Side lock, left / right	-	4	4	4	4
		3a	I6001-**-N03	Central bolt of the side lock	-	4	4	4	4
4		I7009-00-N03	Side locking plate	-	4	4	4	4	
6		I7100-00-N***	Cover of side locking plate, sliding system	-	4	4	4	4	
5		I7012-00-N03	Locking plate for sliding system	-	5	5	5	5	
5a	I7017-00-N03	Locking plate for sliding system, incorrect operation device	-	1	1	1	1		
7	I7011-00-N03	Front damper	-	3	3	3	3		
12	K4054-07-N03	Extension lockfor corner transmission 680 mm, 1 MR	-	1	1	1	1		
14	K4071-07-N03	Extension lockL=720, 1 MR, without possibility to cut	-	1	1	1	1		

** Profile-depending elements

*** color: N01 - white RAL9016

N02 - brown RAL8022

N03 - silver

N05 - golden

N06 - bronze

N07 - black RAL9005

N09 - anthracite gray RAL7016

SMART GLIDE TECH hardware set - Scheme 2
 (position of the handle in the center*)

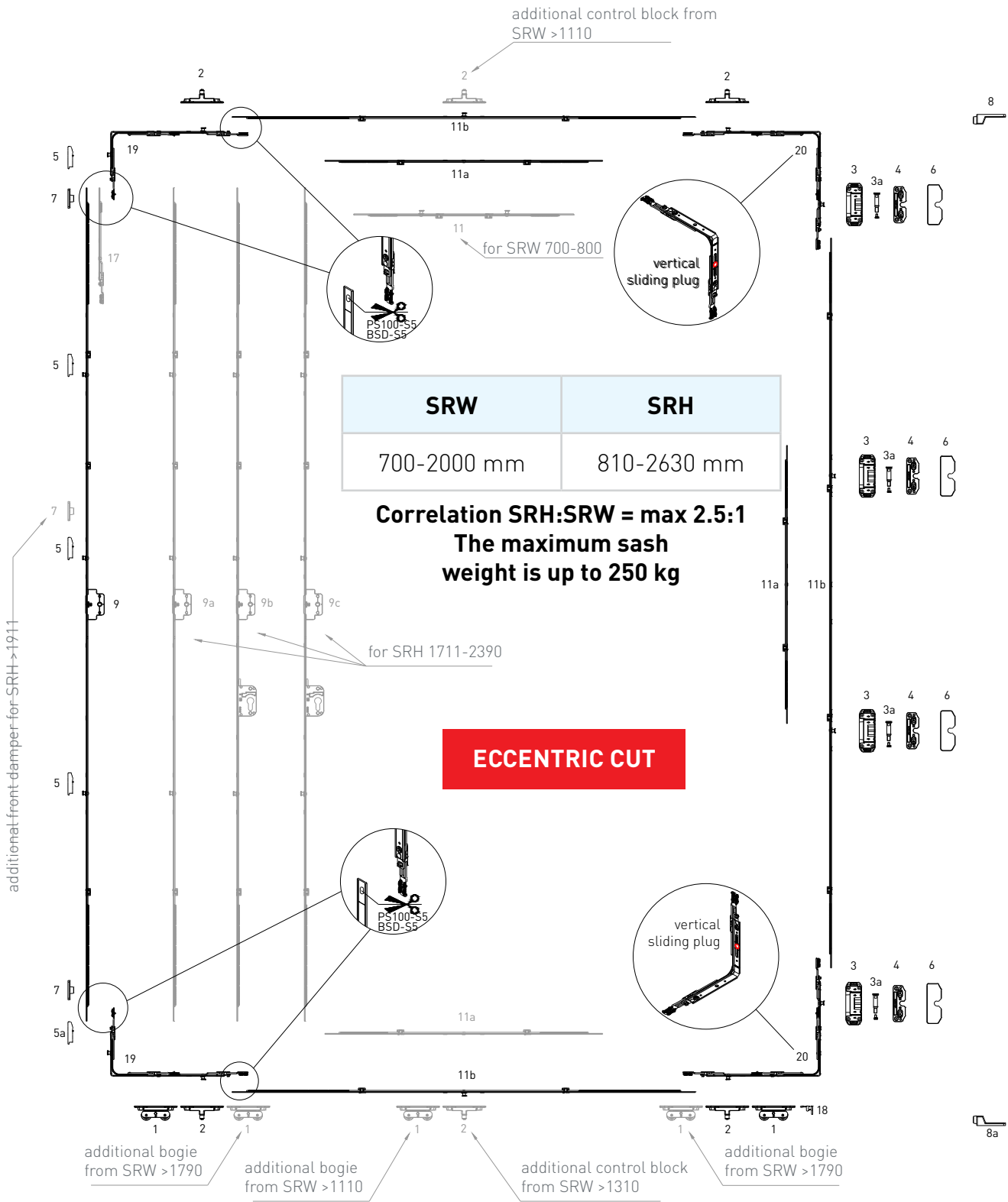

* for application range 2391-2630, the handle is offset downwards by 1-240 mm

SMART GLIDE TECH hardware set - Scheme 2 (position of the handle in the center*)

	N°	Part number	Description	WIDTH				
				800-910	911-1110	1111-1310	1311-1790	1791-2000
Main set	1	I7006-00-N03	Bogie	2	2	3	3	5
	2	I7007-00-L03/R03	Control block, left / right	4	4	5	6	6
	19	K2041-00-N03	Corner transmission, 1 MR, with a scissor extension 180 mm	2	2	2	2	2
	20	K2042-00-N03	Corner transmission, without ML, with a scissor extension 180 mm, with a scissor extension 130 mm	2	2	2	2	2
	8	I7010-**-N03	Opened position stopper	1	1	1	1	1
	8a	I7010-01-N03	Opened position stopper (lower)	1	1	1	1	1
Horizontal extension locks	18	I7014-00-N03	Incorrect operation device	1	1	1	1	1
	11a	K4068-03-N03	Middle connection, L=320, without ML	2	0	0	0	0
		K4068-05-N03	Middle connection, L=520, without ML	0	2	0	0	0
		K4068-07-N03	Middle connection, L=720, without ML	0	0	1	0	0
	11b	K4033-07-N03	Middle connection, L=720, 1 MR	0	0	1	0	0
		K4033-11-N03	Middle connection, L=1200, 1 MR	0	0	0	2	0
	K4033-17-N03	Middle connection, L=1680, 1 MR	0	0	0	0	2	
810-1010	9	K1054-09-N03	Gear variable L=1000, 751-1230, 1 MR, backset 35 mm	1	1	1	1	1
	3	I7018-**-L03/R03	Side lock, left / right	2	2	2	2	2
	3a	I6001-**-N03	Central bolt of the side lock	2	2	2	2	2
	4	I7009-00-N03	Side locking plate	2	2	2	2	2
	6	I7100-00-N***	Cover of side locking plate, sliding system	2	2	2	2	2
	5	I7012-00-N03	Locking plate for sliding system	2	2	2	2	2
	5a	I7017-00-N03	Locking plate for sliding system, incorrect operation device	1	1	1	1	1
	5	I7012-00-N03	Locking plate, sliding system	2	2	2	2	2
	7	I7011-00-N03	Front damper	2	2	2	2	2
	11a	K4068-05-N03	Middle connection, L=520, without ML	1	1	1	1	1
1011-1210	9	K1054-09-N03	Gear variable L=1000, 751-1230, 1 MR, backset 35 mm	1	1	1	1	1
	3	I7018-**-L03/R03	Side lock, left / right	2	2	2	2	2
	3a	I6001-**-N03	Central bolt of the side lock	2	2	2	2	2
	4	I7009-00-N03	Side locking plate	2	2	2	2	2
	6	I7100-00-N***	Cover of side locking plate, sliding system	2	2	2	2	2
	5	I7012-00-N03	Locking plate for sliding system	2	2	2	2	2
	5a	I7017-00-N03	Locking plate for sliding system, incorrect operation device	1	1	1	1	1
	7	I7011-00-N03	Front damper	2	2	2	2	2
	11a	K4068-07-N03	Middle connection, L=720, without ML	1	1	1	1	1
	1211-1430	9	K1054-11-N03	Gear variable L=1200, 950-1430, 1 MR, backset 35 mm	1	1	1	1
3		I7018-**-L03/R03	Side lock, left / right	3	3	3	3	3
3a		I6001-**-N03	Central bolt of the side lock	3	3	3	3	3
4		I7009-00-N03	Side locking plate	3	3	3	3	3
6		I7100-00-N***	Cover of side locking plate, sliding system	3	3	3	3	3
5		I7012-00-N03	Locking plate for sliding system	2	2	2	2	2
5a		I7017-00-N03	Locking plate for sliding system, incorrect operation device	1	1	1	1	1
7		I7011-00-N03	Front damper	2	2	2	2	2
11b		K4033-11-N03	Middle connection, L=1200, 1 MR	1	1	1	1	1



	N°	Part number	Description	WIDTH				
				800-910	911-1110	1111-1310	1311-1790	1791-2000
1431-1690	9	K1054-14-N03	Gear variable L=1480, 1231-1710, 2 MR, backset 35 mm	1	1	1	1	1
	3	I7018-**-L03/R03	Side lock, left / right	3	3	3	3	3
	3a	I6001-**-N03	Central bolt of the side lock	3	3	3	3	3
	4	I7009-00-N03	Side locking plate	3	3	3	3	3
	6	I7100-00-N***	Cover of side locking plate, sliding system	3	3	3	3	3
	5	I7012-00-N03	Locking plate for sliding system	3	3	3	3	3
	5a	I7017-00-N03	Locking plate for sliding system, incorrect operation device	1	1	1	1	1
	5	I7012-00-N03	Locking plate, sliding system	4	4	4	4	4
	7	I7011-00-N03	Front damper	2	2	2	2	2
	11b	K4033-11-N03	Middle connection, L=1200, 1 MR	1	1	1	1	1
1691-1910	9	K1054-16-N03	Gear variable L=1680, 1431-1910, 2 MR, backset 35 mm	1	1	1	1	1
	9a	K1094-16-N03	Gear variable L=1680, 1431-1910, 2 MR, backset 35 mm, 2-side handle	1	1	1	1	1
	9b	K1095-16-N03	Gear variable L=1680, 1431-1910, 2 MR, backset 35 mm, PZ=250 mm	1	1	1	1	1
	9c	K1096-16-N03	Gear variable L=1680, 1431-1910, 2 MR, backset 35 mm, PZ=250 mm, 2-side handle	1	1	1	1	1
	3	I7018-**-L03/R03	Side lock, left / right	3	3	3	3	3
	3a	I6001-**-N03	Central bolt of the side lock	3	3	3	3	3
	4	I7009-00-N03	Side locking plate	3	3	3	3	3
	6	I7100-00-N***	Cover of side locking plate, sliding system	3	3	3	3	3
	5	I7012-00-N03	Locking plate for sliding system	3	3	3	3	3
	5a	I7017-00-N03	Locking plate for sliding system, incorrect operation device	1	1	1	1	1
5	I7012-00-N03	Locking plate, sliding system	4	4	4	4	4	
7	I7011-00-N03	Front damper	2	2	2	2	2	
11b	K4033-17-N03	Middle connection, L=1680, 1431-1910, 1 MR	1	1	1	1	1	
1911-2170	9	K1054-21-N03	Gear variable L=2160, 1911-2390, 3 MR, backset 35 mm	1	1	1	1	1
	9a	K1094-21-N03	Gear variable L=2160, 1911-2390, 3 MR, backset 35 mm, 2-side handle	1	1	1	1	1
	9b	K1095-21-N03	Gear variable L=2160, 1911-2390, 3 MR, backset 35 mm, PZ=250 mm	1	1	1	1	1
	9c	K1096-21-N03	Gear variable L=2160, 1911-2390, 3 MR, backset 35 mm, PZ=250 mm, 2-side handle	1	1	1	1	1
	3	I7018-**-L03/R03	Side lock, left / right	3	3	3	3	3
	3a	I6001-**-N03	Central bolt of the side lock	3	3	3	3	3
	4	I7009-00-N03	Side locking plate	3	3	3	3	3
	6	I7100-00-N***	Cover of side locking plate, sliding system	3	3	3	3	3
	5	I7012-00-N03	Locking plate for sliding system	4	4	4	4	4
	5a	I7017-00-N03	Locking plate for sliding system, incorrect operation device	1	1	1	1	1
7	I7011-00-N03	Front damper	3	3	3	3	3	
11b	K4033-16-N03	Middle connection, L=1680, 1431-1910, 2 MR	1	1	1	1	1	

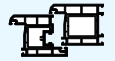

		WIDTH						
		800-910	911-1110	1111-1310	1311-1790	1791-2000		
HEIGHT	Nº	Part number	Description					
	2171-2390	9	K1054-21-N03	Gear variable L=2160, 1911-2390, 3 MR, backset 35 mm	1	1	1	1
9a		K1094-21-N03	Gear variable L=2160, 1911-2390, 3 MR, backset 35 mm, 2-side handle	1	1	1	1	1
9b		K1095-21-N03	Gear variable L=2160, 1911-2390, 3 MR, backset 35 mm, PZ=250 mm	1	1	1	1	1
9c		K1096-21-N03	Gear variable L=2160, 1911-2390, 3 MR, backset 35 mm, PZ=250 mm, 2-side handle	1	1	1	1	1
3		I7018-**-L03/R03	Side lock, left / right	4	4	4	4	4
3a		I6001-**-N03	Central bolt of the side lock	4	4	4	4	4
4		I7009-00-N03	Side locking plate	4	4	4	4	4
6		I7100-00-N***	Cover of side locking plate, sliding system	4	4	4	4	4
5		I7012-00-N03	Locking plate for sliding system	4	4	4	4	4
5a		I7017-00-N03	Locking plate for sliding system, incorrect operation device	1	1	1	1	1
5		I7012-00-N03	Locking plate, sliding system	5	5	5	5	5
7		I7011-00-N03	Front damper	3	3	3	3	3
11b		K4033-22-N03	Middle connection, L=2160, 1911-2390, 2 MR	1	1	1	1	1
2391-2630*	9	K1054-21-N03	Gear variable L=2160, 1911-2390, 3 MR, backset 35 mm	-	1	1	1	1
	9a	K1094-21-N03	Gear variable L=2160, 1911-2390, 3 MR, backset 35 mm, 2-side handle	-	1	1	1	1
	9b	K1095-21-N03	Gear variable L=2160, 1911-2390, 3 MR, backset 35 mm, PZ=250 mm	-	1	1	1	1
	9c	K1096-21-N03	Gear variable L=2160, 1911-2390, 3 MR, backset 35 mm, PZ=250 mm, 2-side handle	-	1	1	1	1
	17	K4057-02-N03	Extension lockL=240, without ML	-	1	1	1	1
	3	I7018-**-L03/R03	Side lock, left / right	-	4	4	4	4
	3a	I6001-**-N03	Central bolt of the side lock	-	4	4	4	4
	4	I7009-00-N03	Side locking plate	-	4	4	4	4
	6	I7100-00-N***	Cover of side locking plate, sliding system	-	4	4	4	4
	5	I7012-00-N03	Locking plate for sliding system	-	4	4	4	4
	5a	I7017-00-N03	Locking plate for sliding system, incorrect operation device	-	1	1	1	1
	5	I7012-00-N03	Locking plate, sliding system	-	5	5	5	5
	7	I7011-00-N03	Front damper	-	3	3	3	3
11b	K4033-22-N03	Middle connection, L=2160, 1911-2390, 2 MR	-	1	1	1	1	

* for application range 2391-2630, the handle is offset downwards by 1-240 mm

** Profile-depending elements

*** color: N01 - white RAL9016

N02 - brown RAL8022

N03 - silver

N05 - golden

N06 - bronze

N07 - black RAL9005

N09 - anthracite gray RAL7016

**SMART GLIDE TECH hardware set - Scheme 2
(handle position G=1000)**

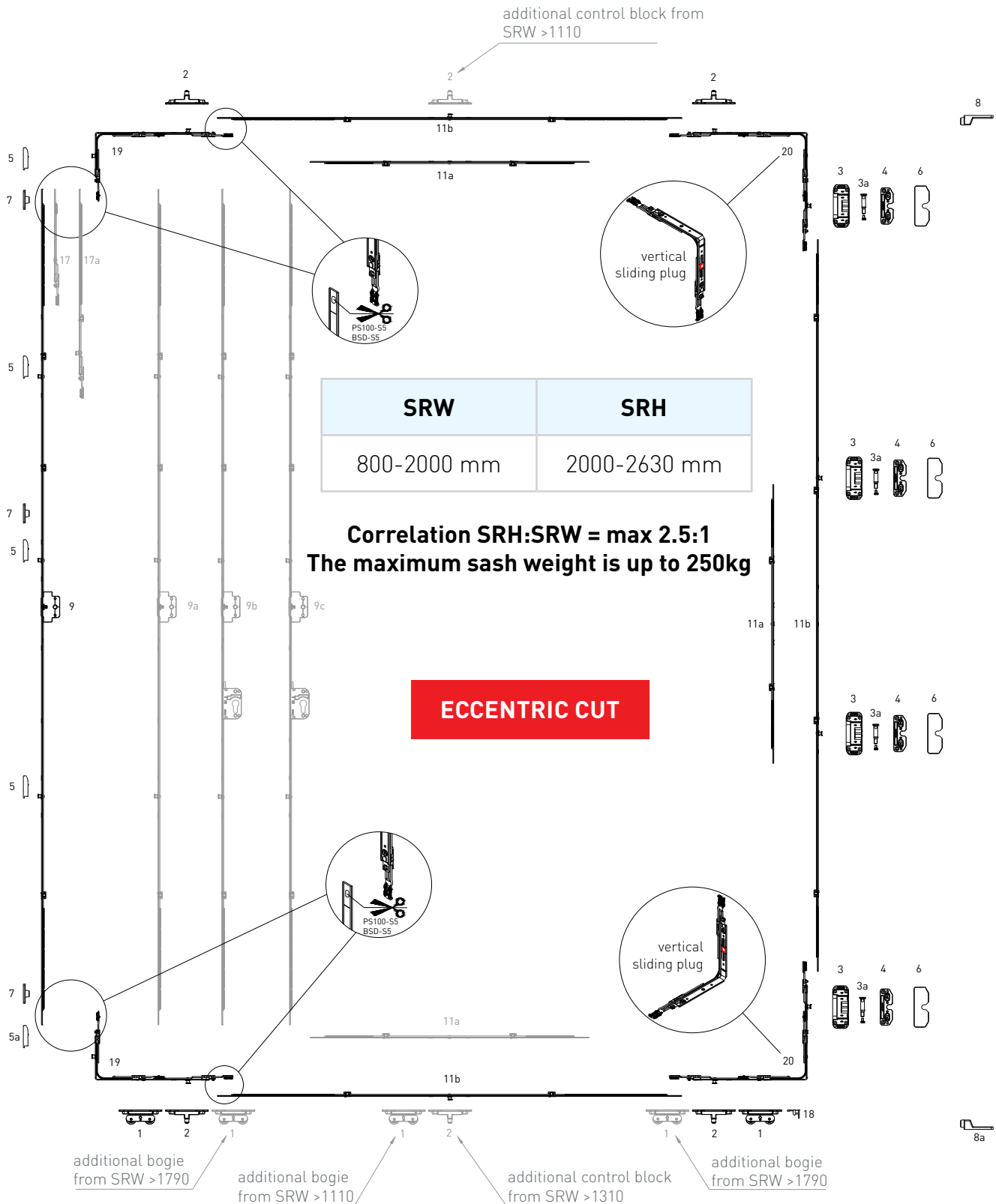



SMART GLIDE TECH hardware set - Scheme 2 (handle position G=1000)

					WIDTH				
		Nº	Part number	Description	800-910	911-1110	1111-1310	1311-1790	1791-2000
Mainset	1	I7006-00-N03	Bogie		2	2	3	3	5
	2	I7007-00-L03/R03	Control block, left / right		4	4	5	6	6
	19	K2041-00-N03	Corner transmission, 1 MR, with stay extension 180 mm		2	2	2	2	2
	15	K2042-00-N03	Corner transmission, without ML, with stay extension 180 mm, with stay extension 130 mm		2	2	2	2	2
	8	I7010-**-N03	Opened position stopper		1	1	1	1	1
	8a	I7010-01-N03	Opened position stopper (lower)		1	1	1	1	1
	18	I7014-00-N03	Anti-tilt device		1	1	1	1	1
	Horizontal extension locks	11a	K4068-03-N03	Middle connection, L = 320, without ML		2	0	0	0
K4068-05-N03			Middle connection, L = 520, without ML		0	2	0	0	0
K4068-07-N03			Middle connection, L = 720, without ML		0	0	1	0	0
11b		K4033-07-N03	Middle connection, L = 720, 1 MR		0	0	1	0	0
		K4033-11-N03	Middle connection, L = 1200, 1 MR		0	0	0	2	0
		K4033-17-N03	Middle connection, L = 1680, 1 MR		0	0	0	0	2
HEIGHT 2000-2195	9	K1054-21-N03	Gear variable L=2160, 1911-2390, 3 MR, backset 35 mm		1	1	1	1	1
	9a	K1094-21-N03	Gear variable L=2160, 1911-2390, 3 MR, backset 35 mm, 2-side handle		1	1	1	1	1
	9b	K1095-21-N03	Gear variable L=2160, 1911-2390, 3 MR, backset 35 mm, PZ=250 mm		1	1	1	1	1
	9c	K1096-21-N03	Gear variable L=2160, 1911-2390, 3 MR, backset 35 mm, PZ=250 mm, 2-side handle		1	1	1	1	1
	3	I7018-**-L03/R03	Side lock, left / right		3	3	3	3	3
	3a	I6001-**-N03	Central bolt of the side lock		3	3	3	3	3
	4	I7009-00-N03	Side locking plate		3	3	3	3	3
	6	I7100-00-N***	Cover of side locking plate, sliding system		3	3	3	3	3
	5	I7012-00-N03	Locking plate for sliding system		4	4	4	4	4
	5a	I7017-00-N03	Locking plate for sliding system, incorrect operation device		1	1	1	1	1
	5	I7012-00-N03	Locking plate, sliding system		5	5	5	5	5
	7	I7011-00-N03	Front damper		3	3	3	3	3
	12	K4054-09-N03	Extension lock for corner transmission 880 mm, 2 MR		1	1	1	1	1



		WIDTH							
Nº	Part number	Description	800-910	911-1110	1111-1310	1311-1790	1791-2000		
HEIGHT	2196-2390	9	K1054-21-N03	Gear variable L=2160, 1911-2390, 3 MR, backset 35 mm	1	1	1	1	1
		9a	K1094-21-N03	Gear variable L=2160, 1911-2390, 3 MR, backset 35 mm, 2-side handle	1	1	1	1	1
		9b	K1095-21-N03	Gear variable L=2160, 1911-2390, 3 MR, backset 35 mm, PZ=250 mm	1	1	1	1	1
		9c	K1096-21-N03	Gear variable L=2160, 1911-2390, 3 MR, backset 35 mm, PZ=250 mm, 2-side handle	1	1	1	1	1
		17	K4057-02-N03	Extension lock L=240, without ML	1	1	1	1	1
		3	I7018-**-L03/R03	Side lock, left / right	4	4	4	4	4
		3a	I6001-**-N03	Central bolt of the side lock	4	4	4	4	4
		4	I7009-00-N03	Side locking plate	4	4	4	4	4
		6	I7100-00-N***	Cover of side locking plate, sliding system	4	4	4	4	4
		5	I7012-00-N03	Locking plate for sliding system	4	4	4	4	4
		5a	I7017-00-N03	Locking plate for sliding system, incorrect operation device	1	1	1	1	1
		7	I7011-00-N03	Front damper	3	3	3	3	3
		12	K4054-05-N03	Extension lock for corner transmission 480 mm, 1 MR	1	1	1	1	1
		14	K4071-07-N03	Extension lock L=720, 1 MR, without possibility to cut	1	1	1	1	1
HEIGHT	2391-2630	9	K1054-21-N03	Gear variable L=2160, 1911-2390, 3 MR, backset 35 mm	-	1	1	1	1
		9a	K1094-21-N03	Gear variable L=2160, 1911-2390, 3 MR, backset 35 mm, 2-side handle	-	1	1	1	1
		9b	K1095-21-N03	Gear variable L=2160, 1911-2390, 3 MR, backset 35 mm, PZ=250 mm	-	1	1	1	1
		9c	K1096-21-N03	Gear variable L=2160, 1911-2390, 3 MR, backset 35 mm, PZ=250 mm, 2-side handle	-	1	1	1	1
		17a	K4050-05-N03	Extension lock 480 mm, 1 MR	-	1	1	1	1
		3	I7018-**-L03/R03	Side lock, left / right	-	4	4	4	4
		3a	I6001-**-N03	Central bolt of the side lock	-	4	4	4	4
		4	I7009-00-N03	Side locking plate	-	4	4	4	4
		6	I7100-00-N***	Cover of side locking plate, sliding system	-	4	4	4	4
		5	I7012-00-N03	Locking plate for sliding system	-	5	5	5	5
		5a	I7017-00-N03	Locking plate for sliding system, incorrect operation device	-	1	1	1	1
		7	I7011-00-N03	Front damper	-	3	3	3	3
		12	K4054-07-N03	Extension lock for corner transmission 680 mm, 1 MR	-	1	1	1	1
		14	K4071-07-N03	Extension lock L=720, 1 MR, without possibility to cut	-	1	1	1	1

** Profile-dependent elements

*** color: N01 - white RAL9016

N02 - brown RAL8022

N03 - silver

N05 - golden

N06 - bronze

N07 - black RAL9005

N09 - anthracite gray RAL7016

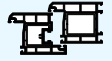

Bogie

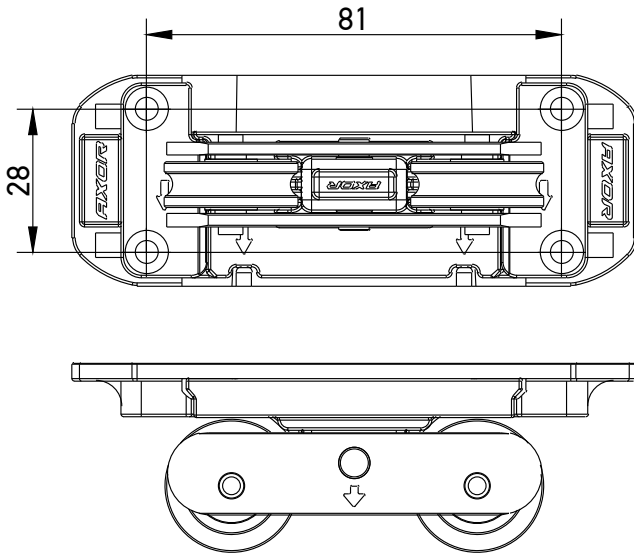

Description	Screw	Part number	Jig number
Bogie	4 / 4x22	17006-00-N03	17201-00-N03

Control block

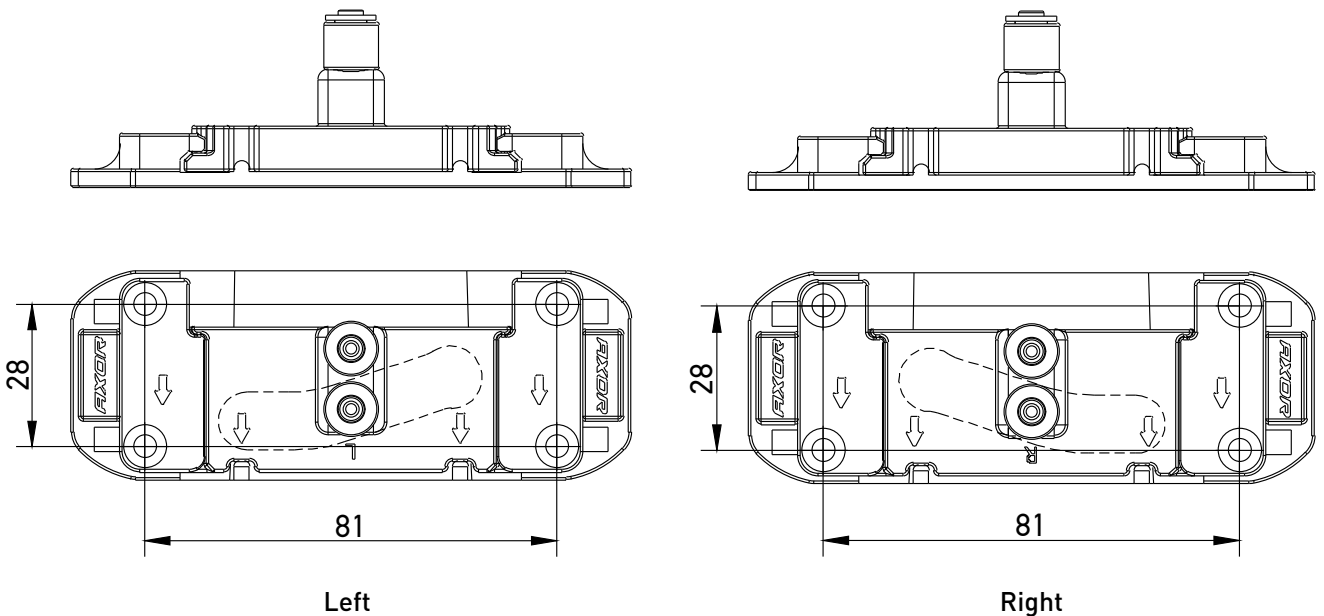

Description	Side opening	Screw	Part number	Jig number
Control block, left	L	4 / 4x22	17007-00-L03	17201-00-N03
Control block, right	R	4 / 4x22	17007-00-R03	17201-00-N03

Side lock

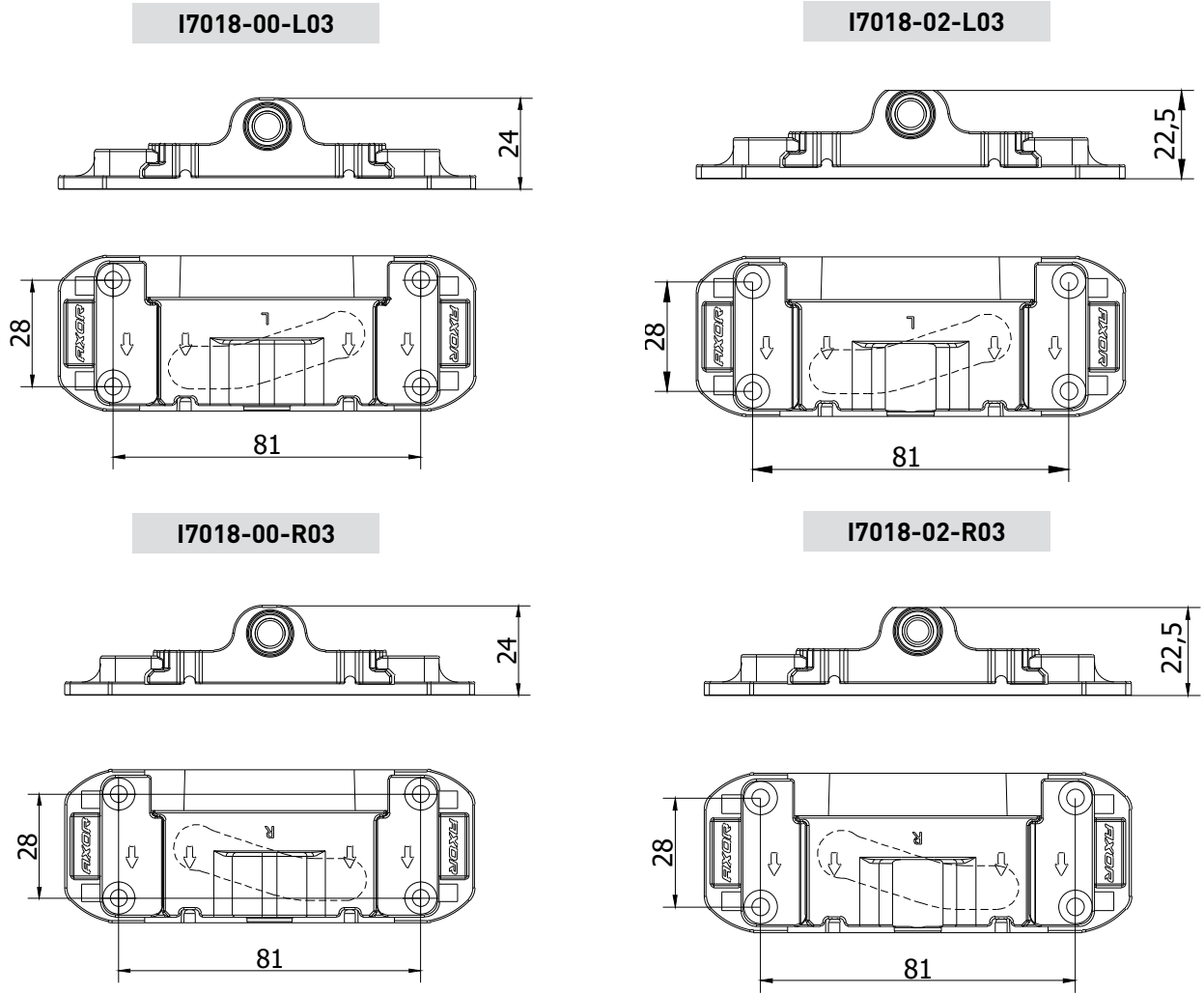

Description	Side opening	Screw	Part number	Jig number	Profile system
Side lock, left/right	L/R	4 / 4x22	I7018-00-L/R03	I7200-00-N03	WDS SL76 ALUPLAST Smart-Slide ALUPLAST Neo REHAU Synego (Intelio) Slide GEALAN SMOOVIO FRAMEX VERATEC
Side lock, narrow, DECCO, left/right	L/R	4 / 4x22	I7018-02-L/R03	I7200-00-N03	DECCO SLIDE



Central bolt of the side lock

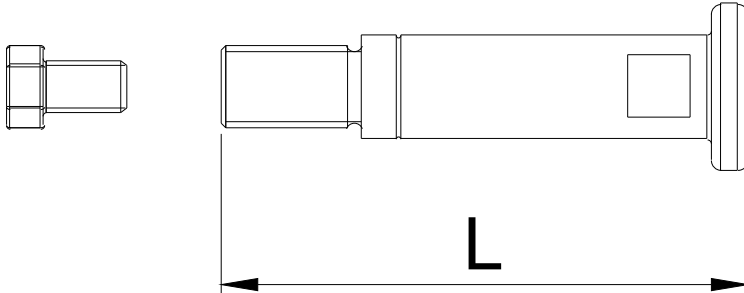

Description	Part number	L,mm	Profile system
Central bolt of the side lock, 50.5 mm, WDS, ALUPLAST	I6001-51-N03	50.5	WDS 76 SL, ALUPLAST Smart-Slide
Central bolt of the side lock, 55.5 mm, FRAMEX	I6001-52-N03	51.5	FRAMEX, VERATEC
Central bolt of the side lock, 51.5 mm, REHAU, GEALAN, DECCO	I6001-56-N03	55.5	REHAU Synego (Intelio) Slide, GEALAN SMOOVIO, DECCO SLIDE
Central bolt of the side lock, 57.5 mm, ALUPLAST neo	I6001-58-N03	57.5	ALUPLAST neo

Side locking plate

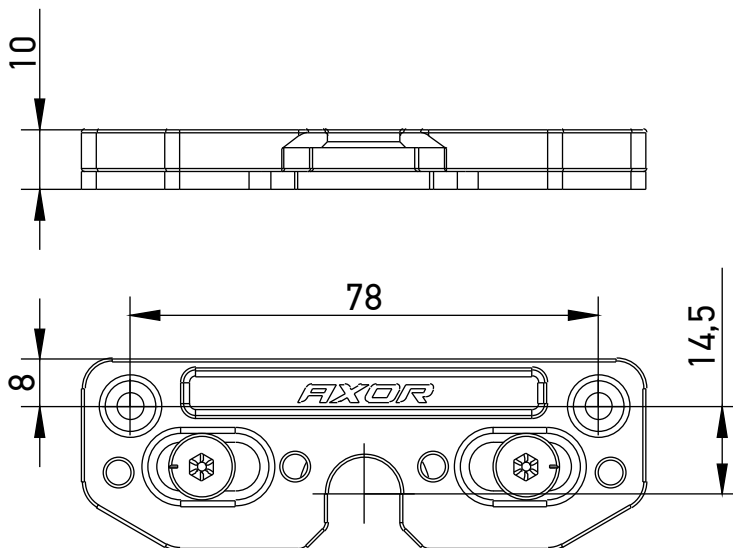

Description	Screw	Part number	Jig number
Side locking plate	2 / 3,9x38	I7009-00-N03	I7202-00-N03



Locking plate, sliding system

I7012-00-N03

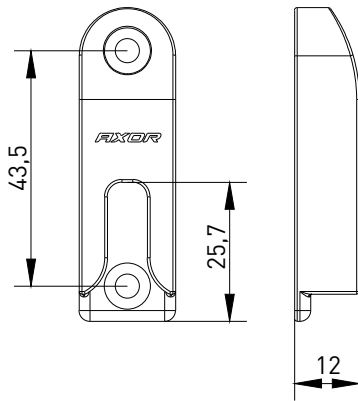

I7017-00-N03

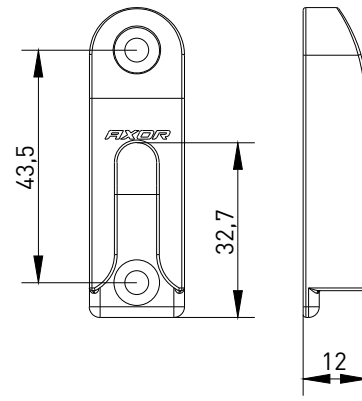

Description	Screw	Part number	Jig number
Locking plate for sliding system	2 / 4x22	I7012-00-N03	I7203-00-N03
Locking plate for sliding system, incorrect operation device	2 / 4x22	I7017-00-N03	-

Opened position stopper

I7010-00-N03

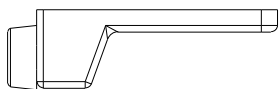
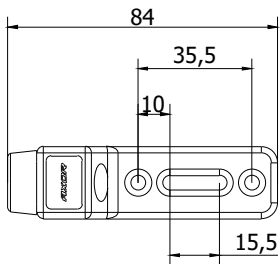

I7010-02-N03

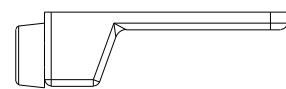
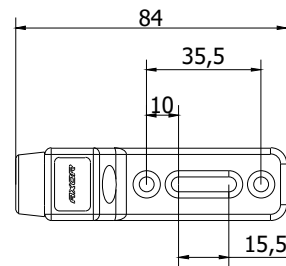

Description	Screw	Part number	Jig number	Profile system
Opened position stopper	3 / 4x22	I7010-00-N03	-	WDS 76 SL, ALUPLAST Smart-Slide, ALUPLAST neo, DECCO SLIDE
Opened position stopper, narrow	3 / 4x22	I7010-02-N03	-	REHAU Synego (Intelio) Slide, GEALAN SMOOV-IO, FRAMEX, VERATEC

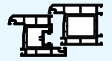

Opened position stopper (lower)

I7010-01-N03

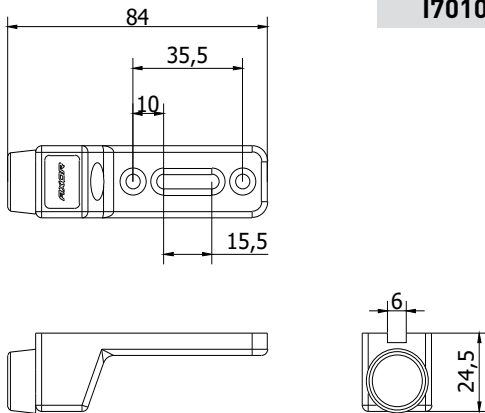

Description	Screw	Part number	Jig number	Profile system
Opened position stopper (lower)	3 / 4x22	I7010-01-N03	-	WDS 76 SL, ALUPLAST Smart-Slide, ALUPLAST neo, REHAU Synego (Intelio) Slide, GEALAN SMOOVIO, DECCO SLIDE, FRAMEX, VERATEC

Anti-tilt device

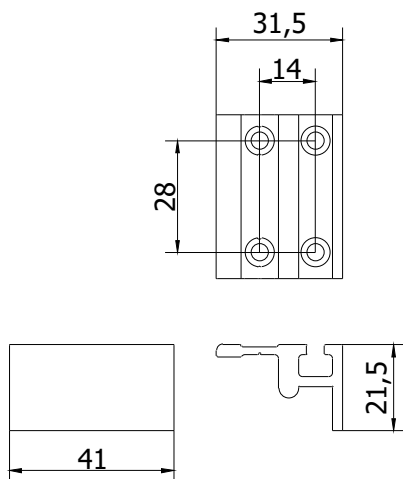

Description	Screw	Part number	Jig number	Profile system
Anti-tilt device	4 / 4x22	I7014-01-N03	-	WDS 76 SL, ALUPLAST Smart-Slide, ALUPLAST neo, REHAU Synego (Intelio) Slide, GEALAN SMOOVIO, DECCO SLIDE, FRAMEX, VERATEC



Front damper

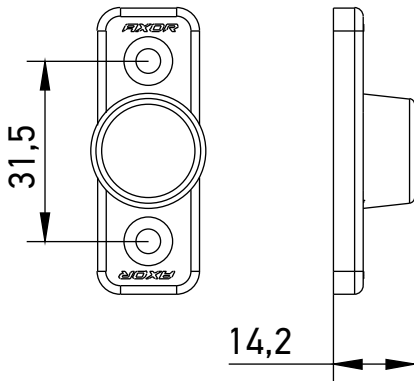

Description	Screw	Part number	Jig number
Front damper	2 / 4x22	I7011-00-N03	-

Cover of side locking plate, sliding system

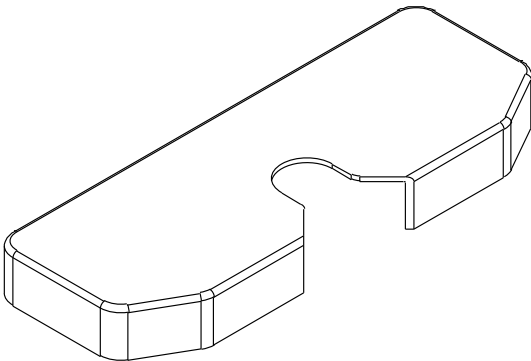

Description	Part number
Cover of side locking plate, sliding system, RAL9016 white	I7100-00-N01
Cover of side locking plate, sliding system, RAL8022 brown	I7100-00-N02
Cover of side locking plate, sliding system, silver	I7100-00-N03
Cover of side locking plate, sliding system, golden	I7100-00-N05
Cover of side locking plate, sliding system, bronze	I7100-00-N06
Cover of side locking plate, sliding system, RAL9005 black	I7100-00-N07
Cover of side locking plate, sliding system, RAL7016 anthracite gray	I7100-00-N09

SMART GT

Section 1.4

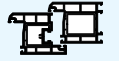

Perimeter strapping elements

Gear variable, backset 35 mm

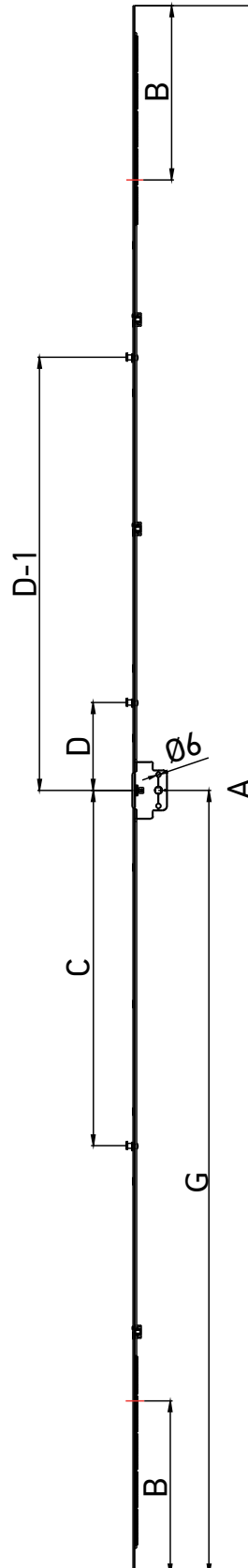
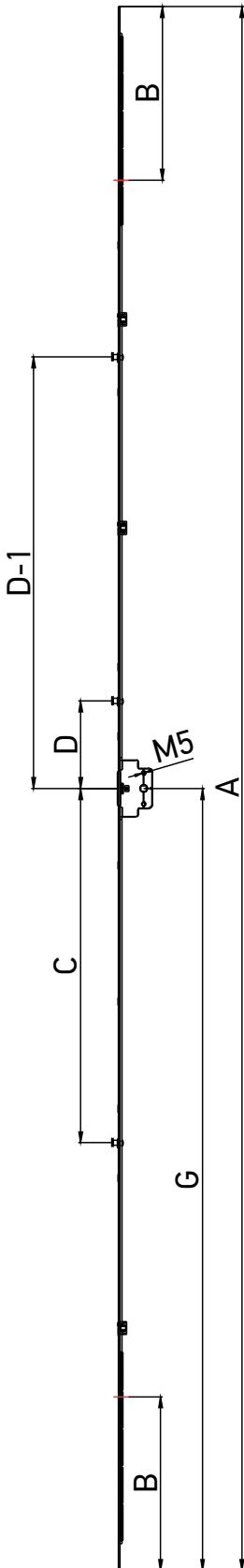
Gear variable, backset 35 mm,
2-side handle

Gear variable, backset 35 mm

Description	SRH		A	B	C	D	D-1	G	Part number
Gear variable L=520, 551-750, backset 35 mm	550-750	2	520	100	-	-	-	275-375	K1054-04-N03
Gear variable L=1000, 751-1230, 1 MR, backset 35 mm	751-1200	4	1000	240	-	121	-	375-600	K1054-09-N03
Gear variable L=1200, 950-1430, 1 MR, backset 35 mm	1201-1430	5	1200	240	-	121	-	600-715	K1054-11-N03
Gear variable L=1480, 1231-1710, 2 MR, backset 35 mm	1431-1710	6	1480	240	289	121	-	715-855	K1054-14-N03
Gear variable L=1680, 1431-1910, 2 MR, backset 35 mm	1711-1910	7	1680	240	389	266	-	855-955	K1054-16-N03
Gear variable L=2160, 1911-2390, 3 MR, backset 35 mm	1911-2390	11	2160	240	489	121	596	955-1195	K1054-21-N03

Gear variable, backset 35 mm, 2-side handle

Description	SRH		A	B	C	D	D-1	G	Part number
Gear variable L=1680, 1431-1910, 2 MR, backset 35 mm, 2-side handle	1711-1910	7	1680	240	389	266	-	855-955	K1094-16-N03
Gear variable L=2160, 1911-2390, 3 MR, backset 35 mm, 2-side handle	1911-2390	11	2160	240	489	121	596	955-1195	K1094-21-N03

SMART GT

Section 1.4



Perimeter strapping elements

Gear variable, backset 35 mm,
lockable 250 mm

Gear variable, backset 35 mm,
lockable 250 mm, 2-side handle

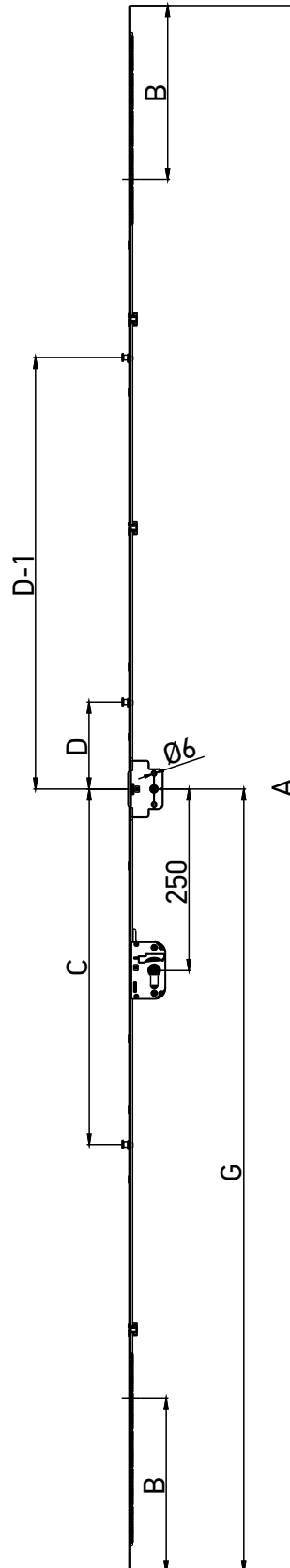
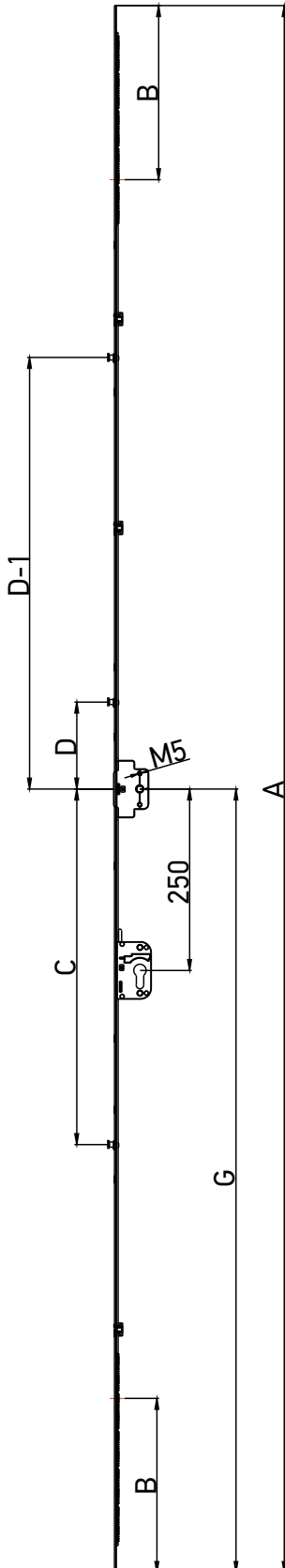

Gear variable, backset 35 mm, lockable 250 mm

Description	SRH		A	B	C	D	D-1	G	Part number
Gear variable L=1680, 1431-1910, 2 MR, backset 35 mm, lockable 250 mm	1711-1910	7	1680	240	389	266	-	855-955	K1095-16-N03
Gear variable L=2160, 1911-2390, 3 MR, backset 35 mm, lockable 250 mm	1911-2390	11	2160	240	489	121	596	955-1195	K1095-21-N03

Gear variable, backset 35 mm, lockable 250 mm, 2-side handle

Description	SRH		A	B	C	D	D-1	G	Part number
Gear variable L=1680, 1431-1910, 2 MR, backset 35 mm, lockable 250 mm, 2-side handle	1711-1910	7	1680	240	389	266	-	855-955	K1096-16-N03
Gear variable L=2160, 1911-2390, 3 MR, backset 35 mm, lockable 250 mm, 2-side handle	1911-2390	11	2160	240	489	121	596	955-1195	K1096-21-N03



Corner transmission

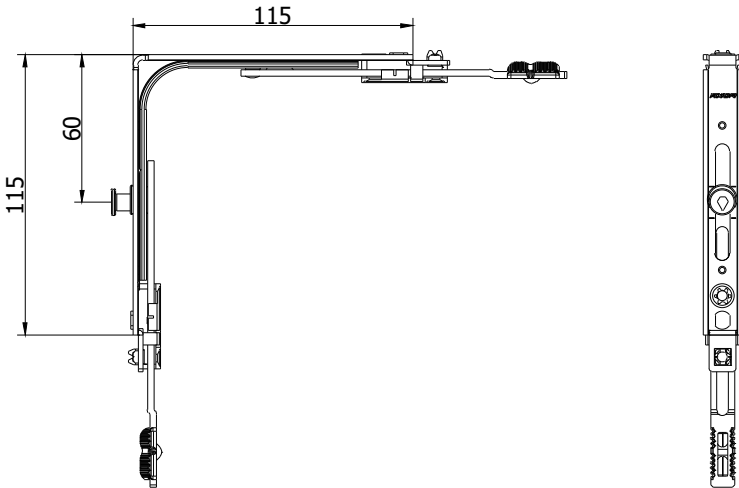

Description	SRH	SRW	Screw	Part number
Corner transmission, 1 ML, 115x115	650-2630	700-2000	4	K2025-00-N03

Corner transmission, without ML

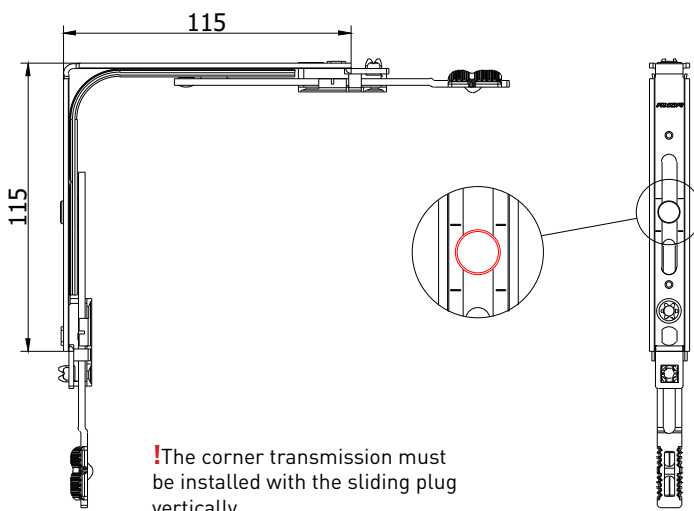

Description	SRH	SRW	Screw	Part number
Corner transmission, 115x115, without ML	650-2630	700-2000	4	K2036-00-N03



Corner transmission, with extension lock 180 mm

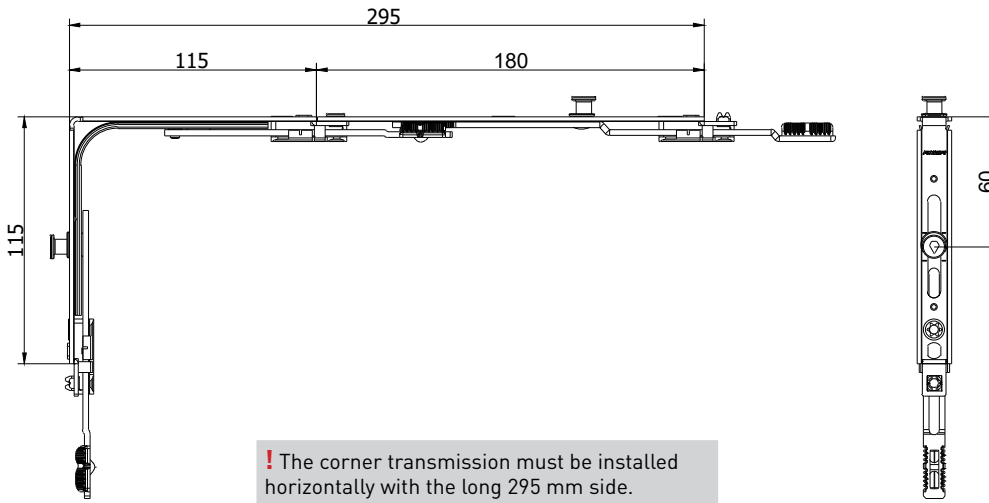

! The corner transmission must be installed horizontally with the long 295 mm side.

Description	SRH	SRW	Screw	Part number
Corner transmission, 1 MR, with extension lock 180 mm	650-2630	800-2000	6	K2041-00-N03

Corner transmission, without ML, with extension lock 180 mm, with extension lock 130 mm

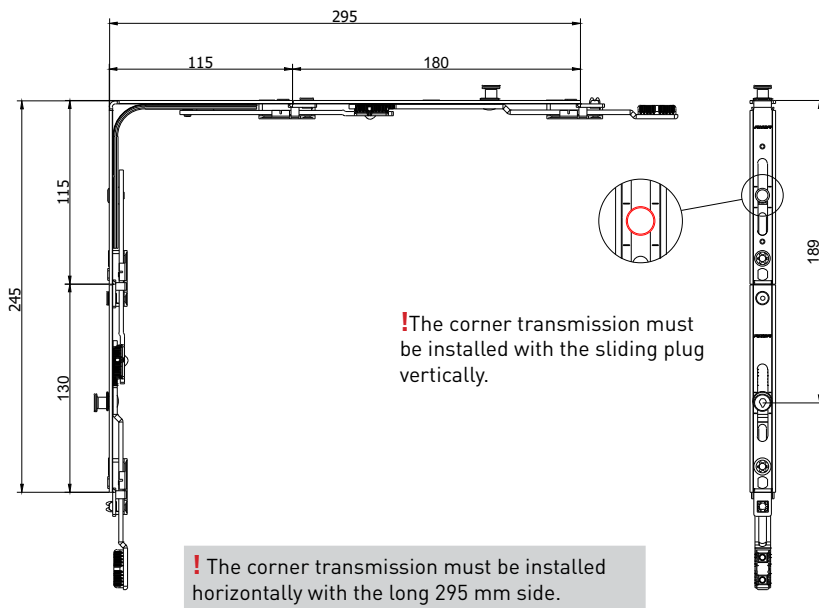

! The corner transmission must be installed with the sliding plug vertically.

! The corner transmission must be installed horizontally with the long 295 mm side.

Description	SRH	SRW	Screw	Part number
Corner transmission without ML, with extension lock 180 mm with extension lock 130 mm	810-2630	800-2000	7	K2042-00-N03

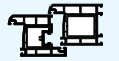

Middle connection, without ML

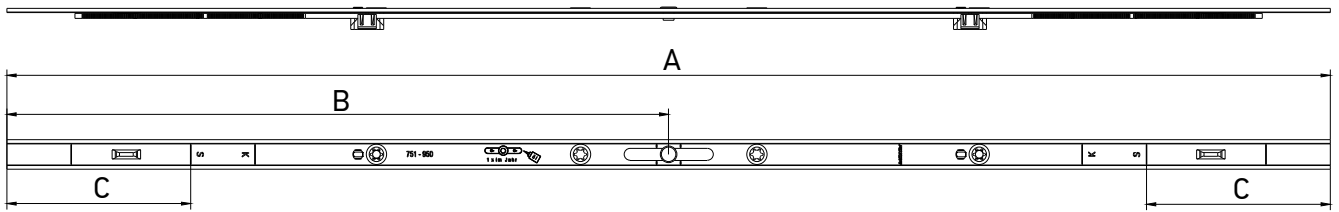

Middle connection, 1 MR

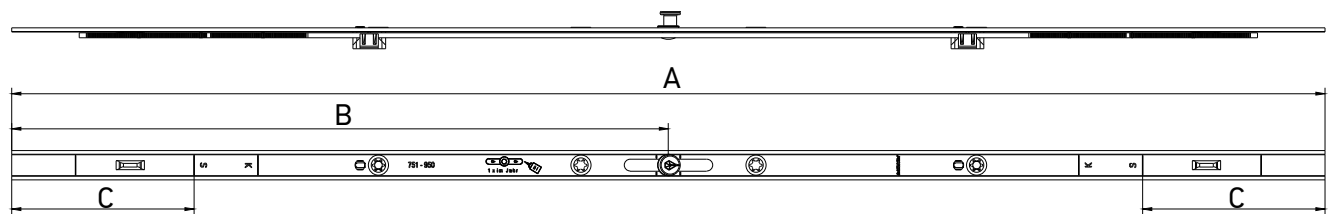

Middle connection, 2 MR

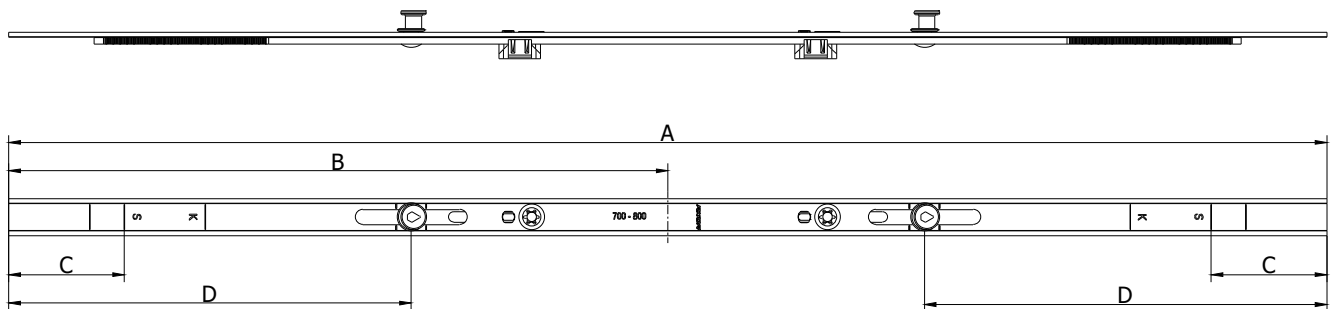



Description	SRW	SRH	Screw	A	B	C	D	Part number
Middle connection, L = 320, 440-550, without ML	801-910	-	1	320	160	55	-	K4068-03-N03
Middle connection, L = 520, 551-750, without ML	911-1110	810-1010	2	520	260	100	-	K4068-05-N03
Middle connection, L = 720, 751-950, without ML	1111-1310	1011-1210	4	720	360	100	-	K4068-07-N03
Middle connection, L=720, 751-950, 1 MR	1111-1310	-	4	720	360	100	360	K4033-07-N03
Middle connection, L=1200, 951-1430, 1 MR	1311-1790	1211-1690	4	1200	600	240	600	K4033-11-N03
Middle connection, L=1680, 1431-1910, 2 MR	-	1911-2170	8	1680	840	240	510	K4033-16-N03
Middle connection, L=1680, 1431-1910, 1 MR	1791-2000	1691-1910	8	1680	840	240	840	K4033-17-N03
Middle connection, L=2160, 1911-2390, 2 MR	-	2170-2630	10	2160	1080	240	750	K4033-22-N03
ΠMiddle connection for sliding system, L = 570, 700-800, 2 MR	700-800	-	2	570	285	50	174	K4069-06-N03



Extension lock

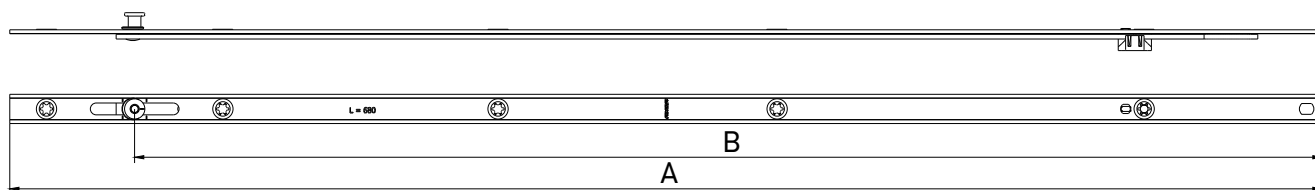

Description	SRW	Screw	A	B	Part number
Extension lock, L=480, 1 MR	1201-1430	4	515	447	K4054-05-N03
Extension lock, L=680, 1 MR	1431-1710	5	715	647	K4054-07-N03
Extension lock, L=880, 2 MR	1431-1710	7	915	847	K4054-09-N03

Extension lock, 240 mm

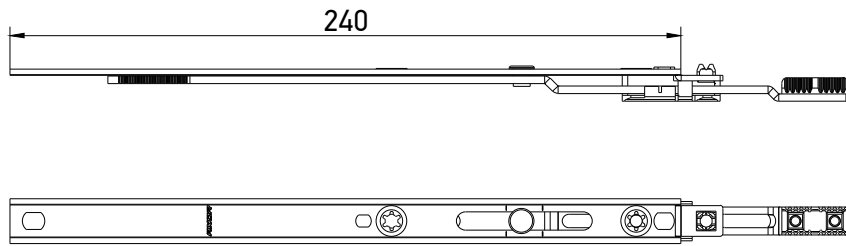

Extension lock, 720 mm, 1 MR

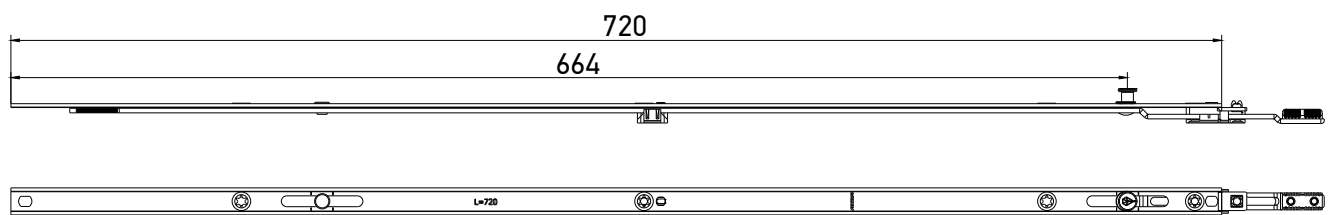

Extension lock, 130 mm, 1 MR

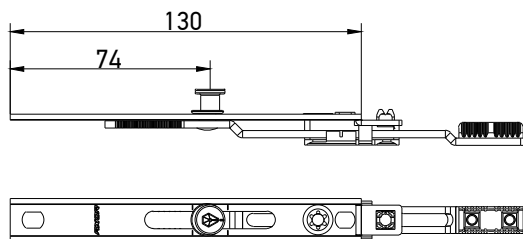

Extension lock, 180 mm, 1 MR

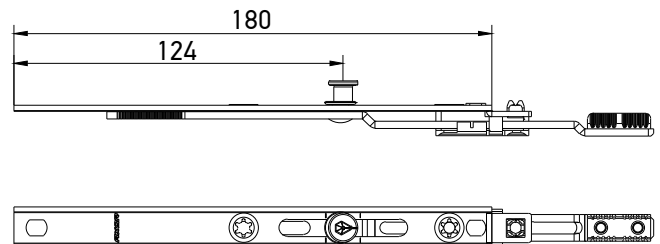

Extension lock, 480 mm, 1 MR

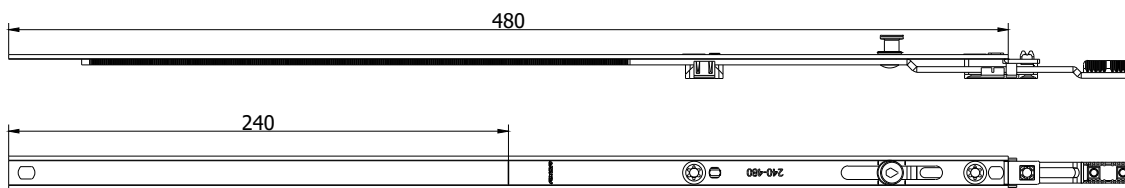

Description	SRH	SRW	Screw	Part number
Extension lock, 240 mm, without ML	2195-2390	-	3	K4057-02-N03
Extension lock, 720 mm, 1 MR, without possibility to cut	2111-2390	-	5	K4071-07-N03
Extension lock, 130 mm, 1 MR	650-2390	-	2	K4050-00-N03
Extension lock, 180 mm, 1 MR	801-1790	801-200	3	K4050-01-N03
Extension lock, 480 mm, 1 MR	2391-2630	-	3	K4050-05-N03

SMART GT

Section 1.5

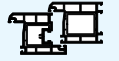

Installation, adjustments, jigs

**Assembly diagram (side lock) - mullion
Scheme 1**

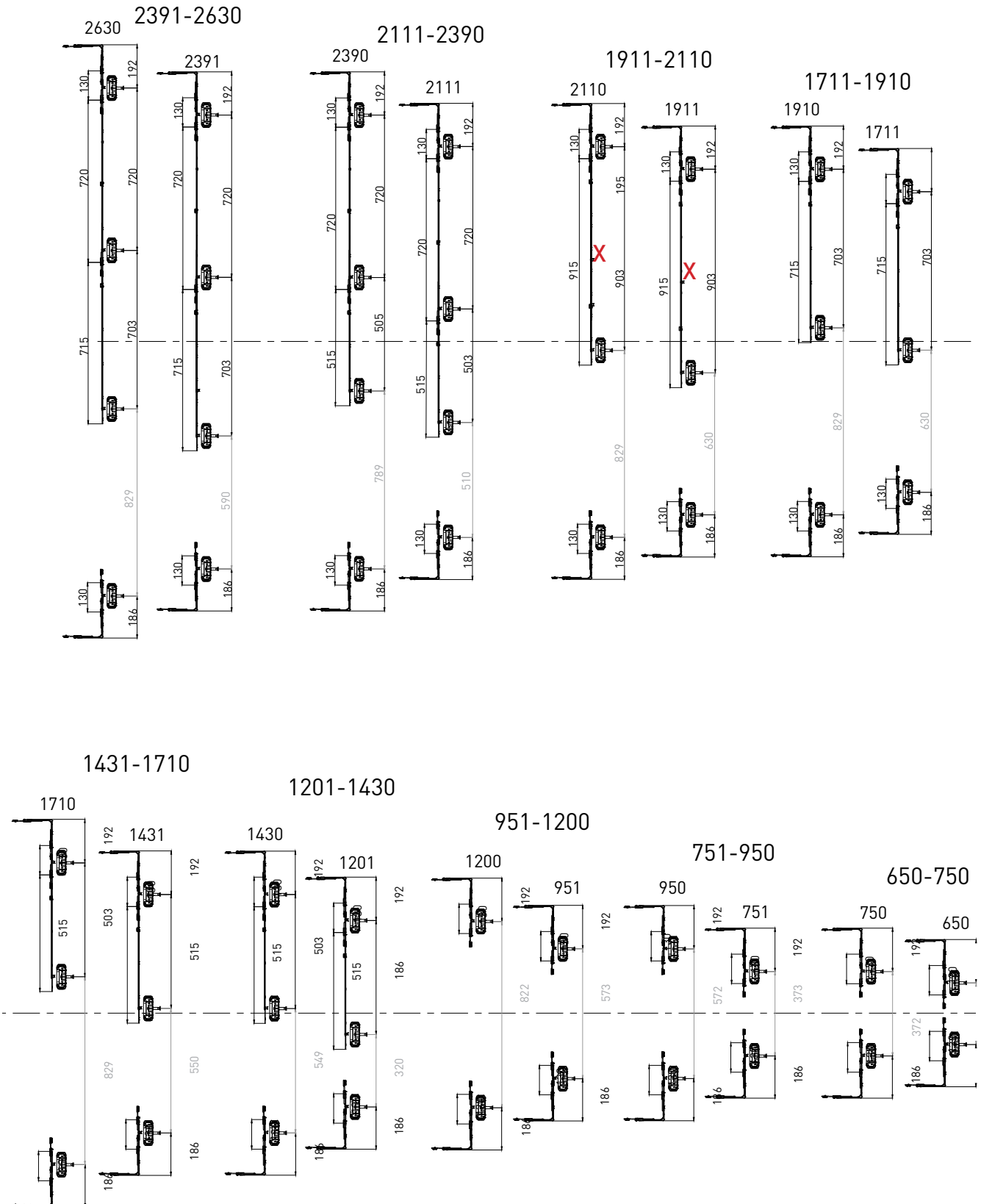

**Assembly diagram (side lock) - mullion
Scheme 2**

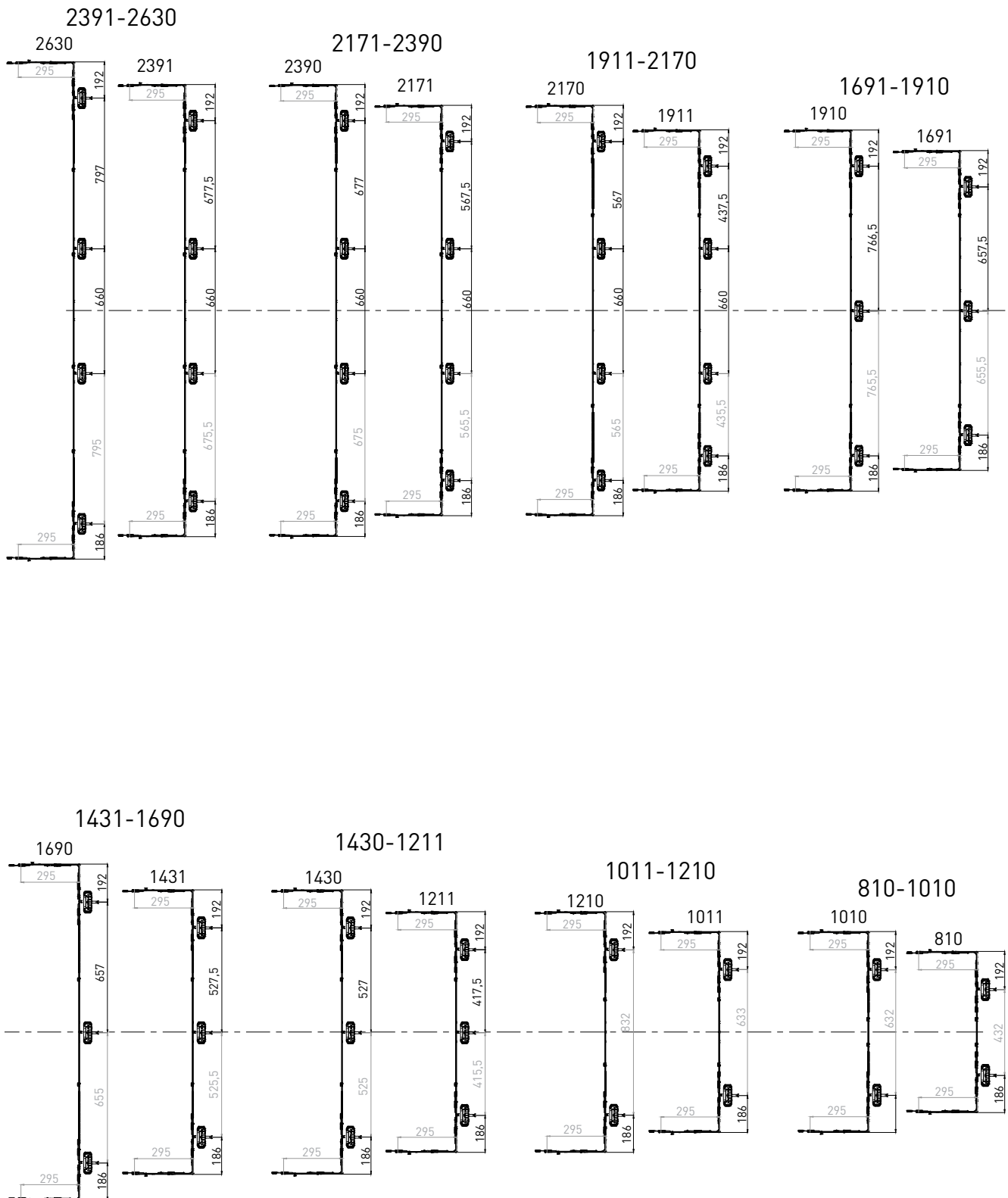

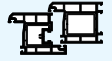

**Assembly diagram (locking plates) - handle side
(position of the handle in the center*)**

Scheme 1

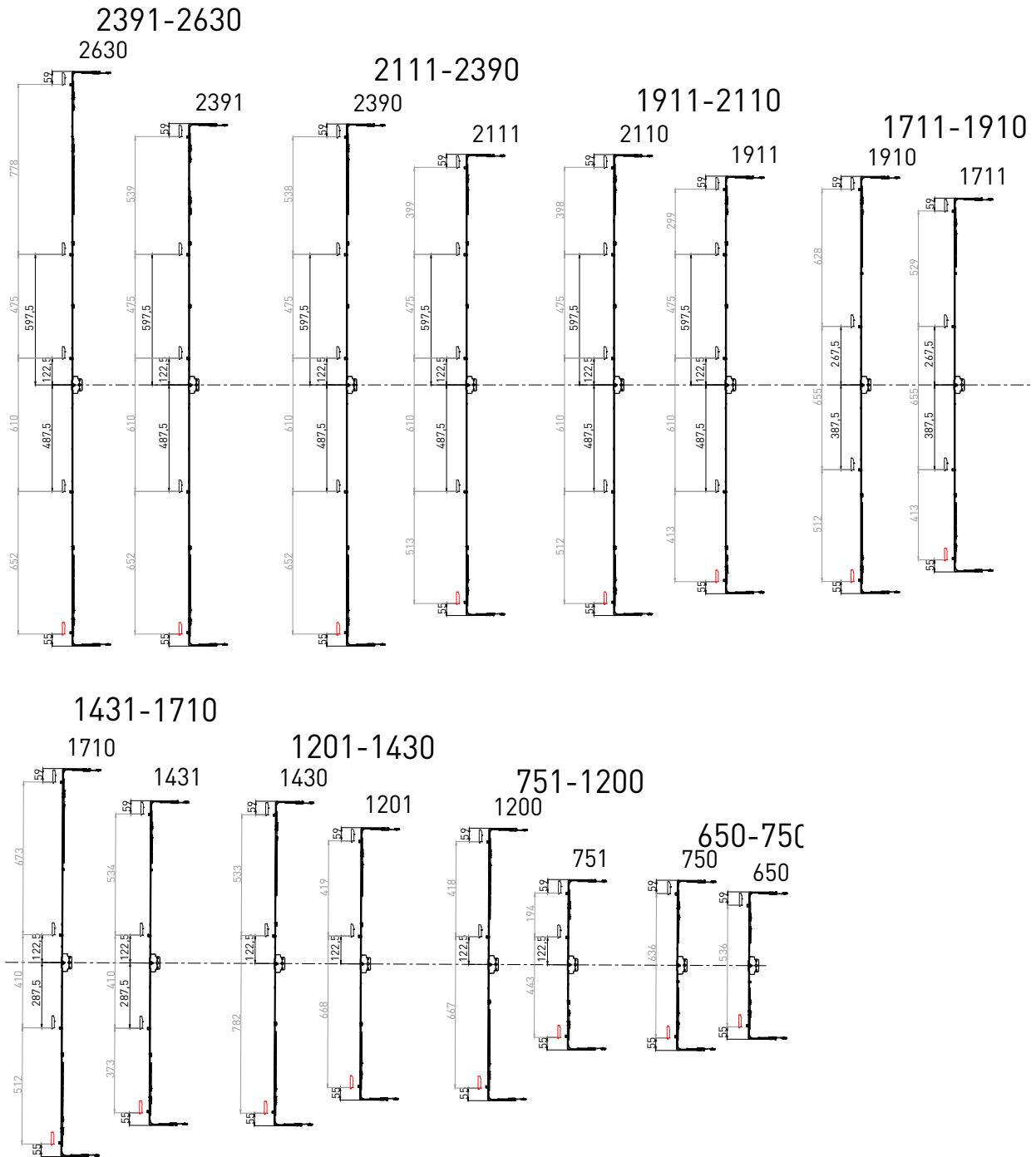

17012-00-N03 Locking plate for sliding system



17017-00-N03 Locking plate for sliding system, incorrect operation device

* For application range 2391-2630, the handle is offset downwards by 1-240 mm

**Assembly diagram (locking plates) - handle side
(position of the handle in the center*)**

Scheme 2

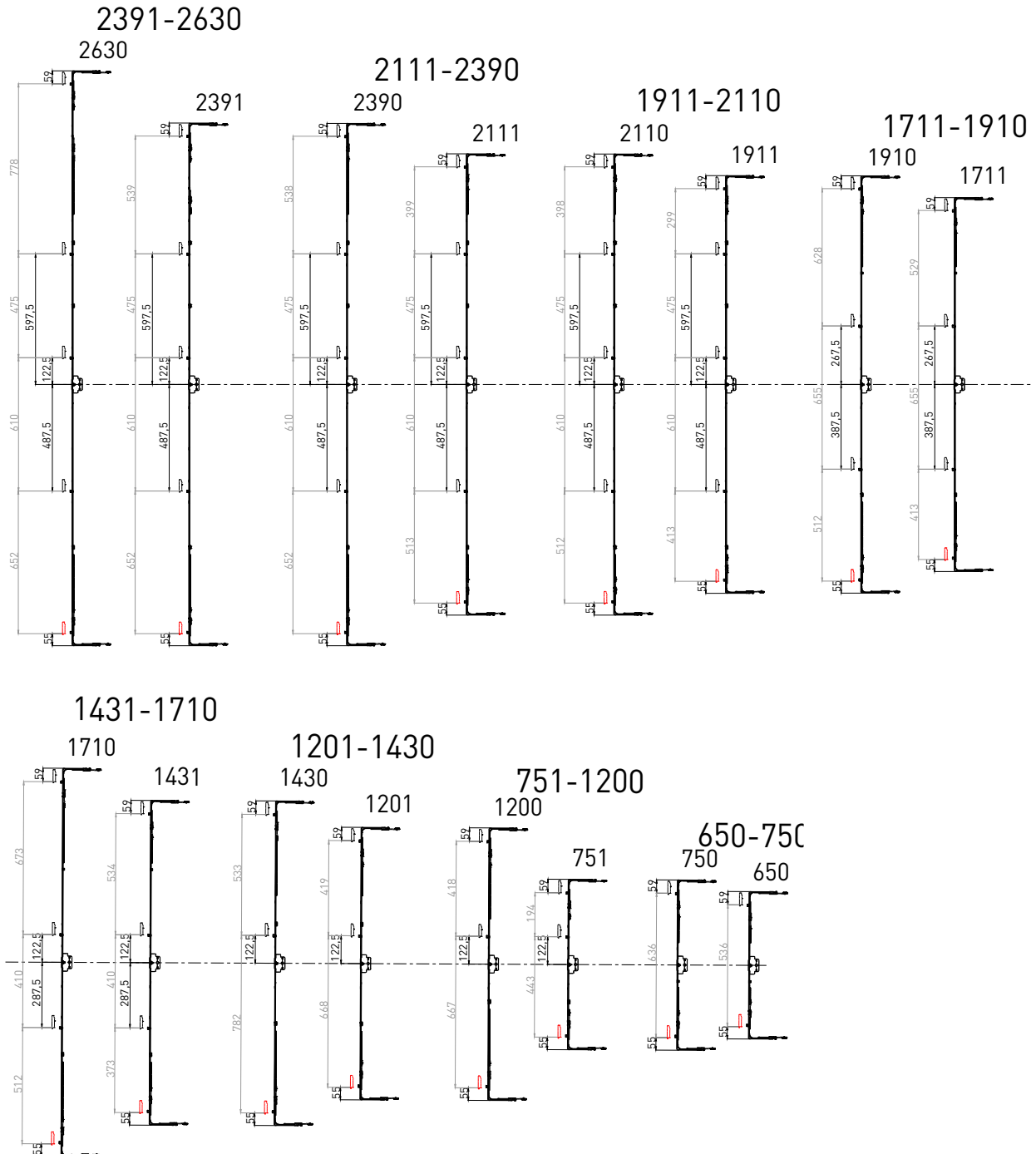

17012-00-N03 Locking plate for sliding system



17017-00-N03 Locking plate for sliding system, incorrect operation device

* For application range 2391-2630, the handle is offset downwards by 1-240 mm

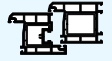

**Assembly diagram (locking plates) - handle side
(handle position G = 1000)**

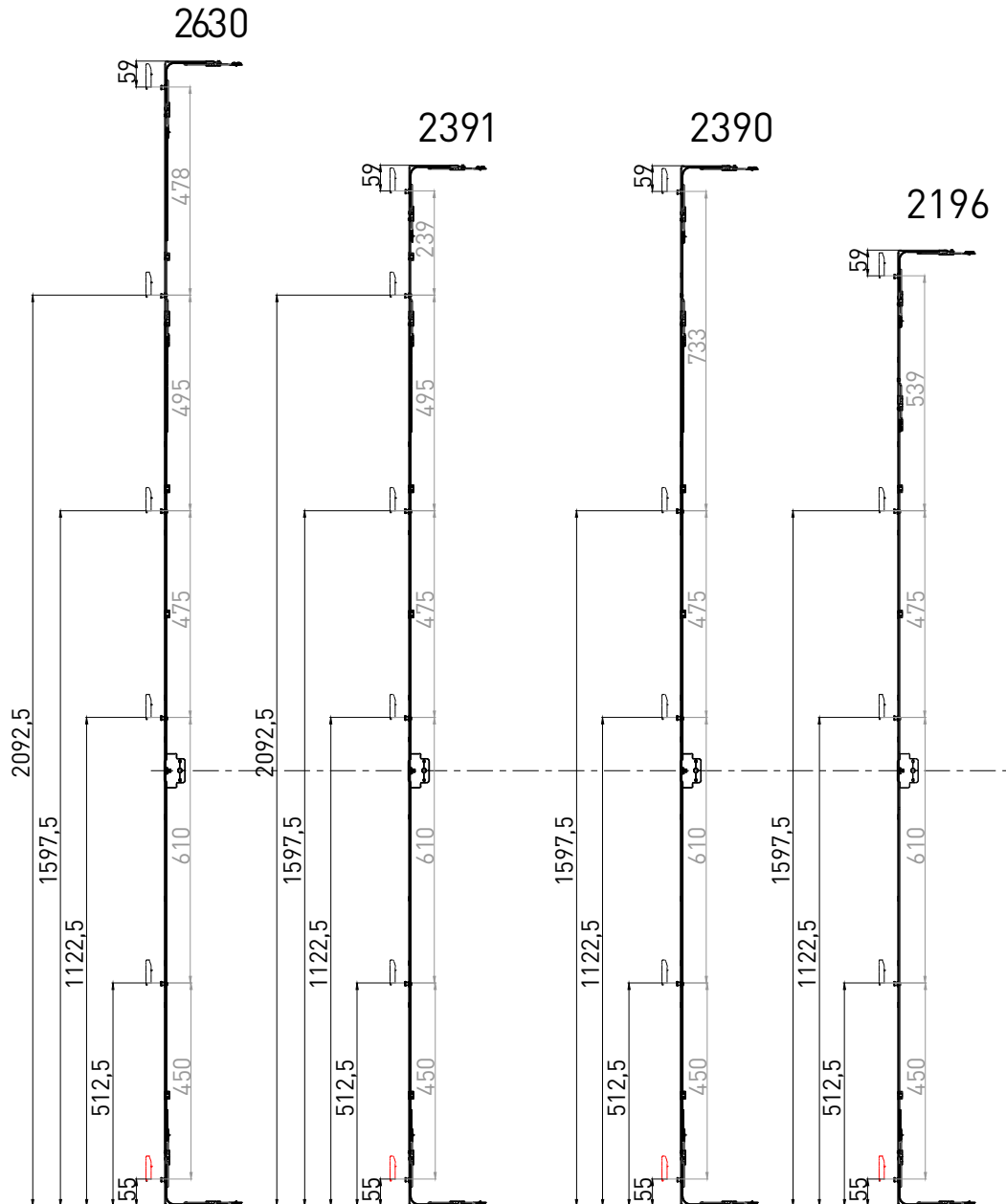

I7012-00-N03 Locking plate for sliding system



I7017-00-N03 Locking plate for sliding system, incorrect operation device

* For application range 2391-2630, the handle is offset downwards by 1-240 mm

**Assembly diagram (locking plates) - handle side
(handle position G = 1000)**

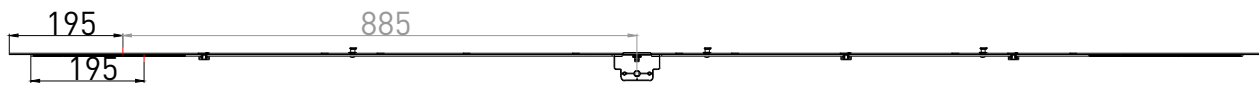
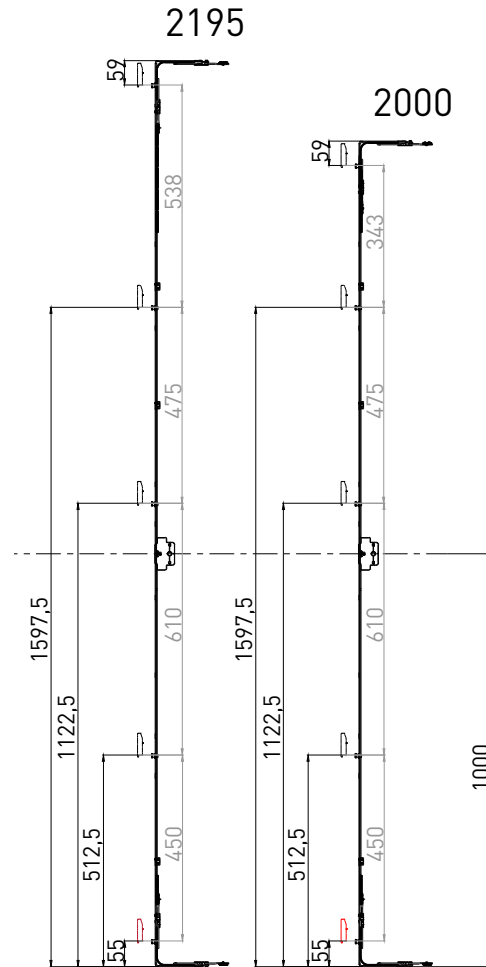

↑
For handle height
G=1000, it is necessary
to cut off 195 mm from
bottom side

K1054-21-N03
K1094-21-N03

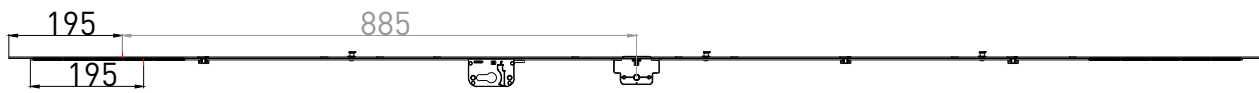

↑
For handle height
G=1000, it is necessary
to cut off 195 mm from
bottom side

K1095-21-N03
K1096-21-N03

 I7012-00-N03 Locking plate for sliding system

 I7017-00-N03 Locking plate for sliding system, incorrect operation device

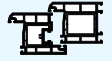

Assembly diagram (bogie, control block) - bottom
Scheme 1,2

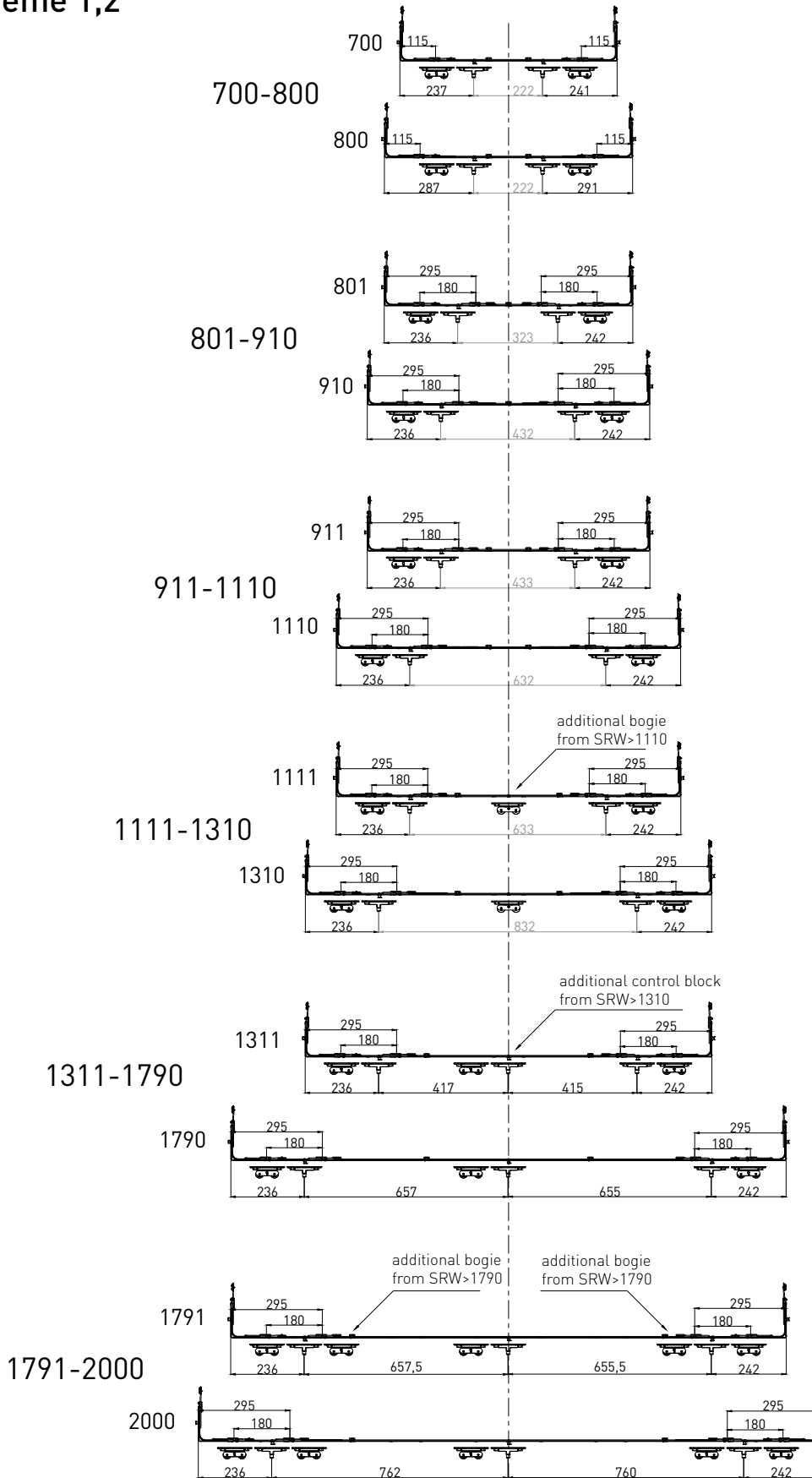

Assembly diagram (control block) - top
Scheme 1,2

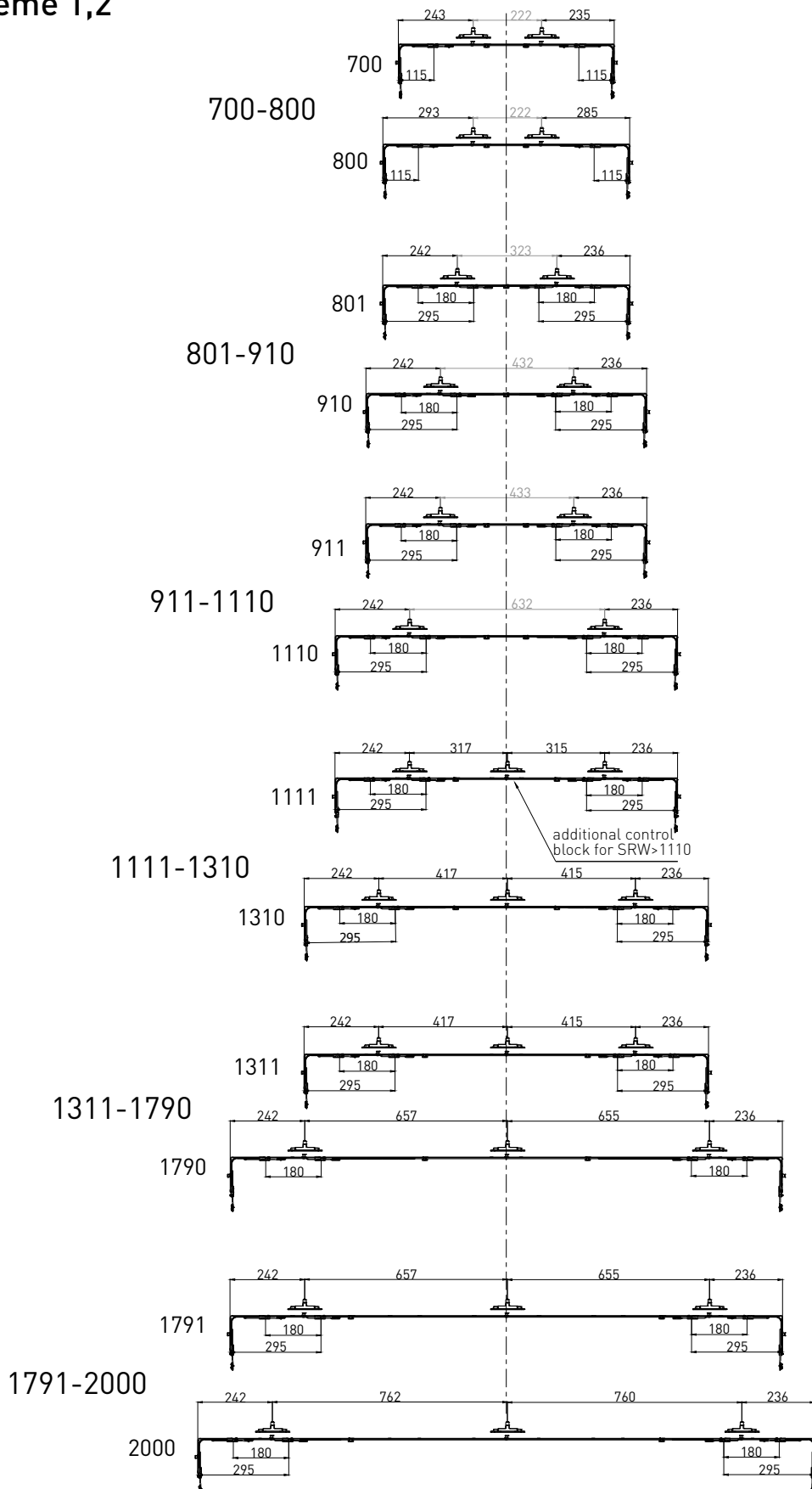

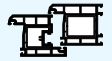

**Installation of the bogie and the control block using a drilling jig.
Left opening. Bottom.**

1. Rotate a handle in open position (180°).
2. Install drilling jig on the locking pin of extension lock. Pay attention: handle side bogie is from the left side, mullion side bogie is from the right side. Drilling jig has to be used accordingly (see marking L).
3. Drill hole Ø3 for bogie and control block.
4. Fix with screws Ø4*22 (alternatively Ø3,9*25).

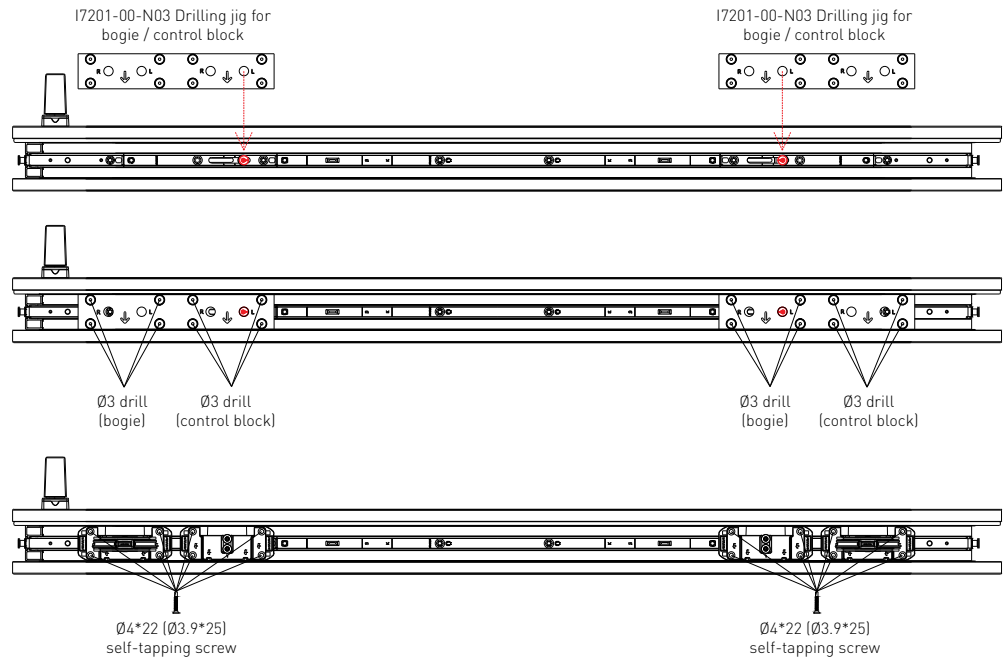

Additional bogie from SRW > 1110

1. Rotate a handle in open position (180°).
2. Install drilling jig on the locking pin of extension lock. Pay attention: handle side bogie is from the left side, mullion side bogie is from the right side. Drilling jig has to be used accordingly (see marking L). Additional bogie has to be placed in the middle of sash (SRW).
3. Drill hole Ø3 for bogie and control block. For additional bogie has to be drilled just for bogie.
4. Fix with screws Ø4*22 (alternatively Ø3,9*25).

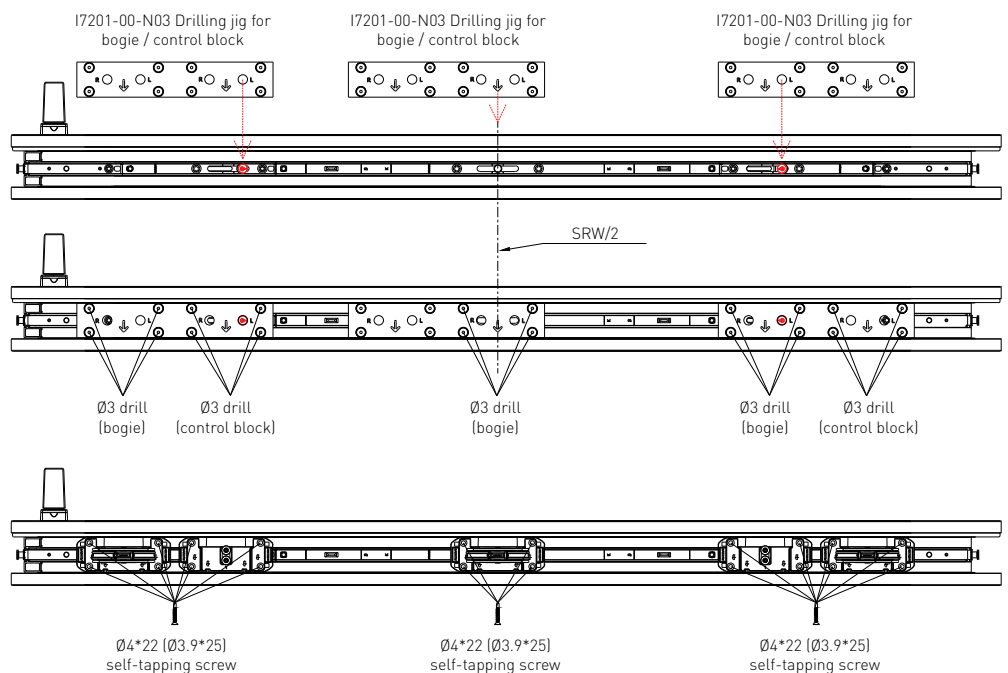



**Installation of the bogie and the control block using a drilling jig.
Left opening. Bottom.**

Additional bogie and control block for SRW > 1310

1. Rotate a handle in open position (180°).
2. Install drilling jig on the locking pin of extension lock. Pay attention: handle side bogie is from the left side, mullion side bogie is from the right side. Additional bogie is located on the left side of control block on the same position of handle side. Drilling jig has to be used accordingly (see marking L).
3. Drill hole Ø3 for bogie and control block.
4. Fix with screws Ø4*22 (alternatively Ø3,9*25).

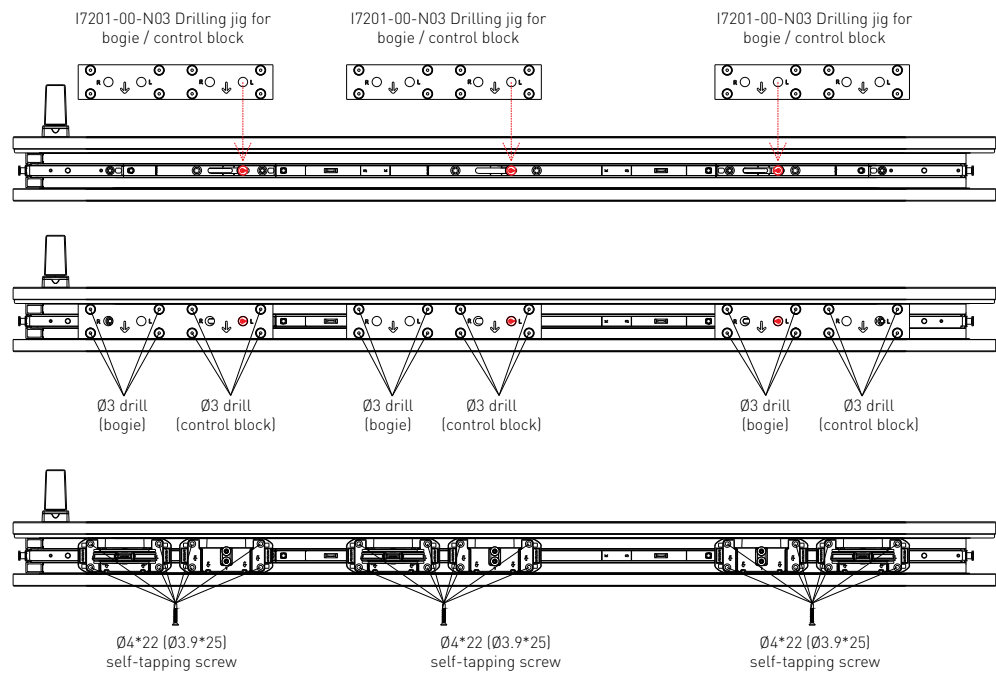

Additional bogie from SRW > 1790

1. Turn the handle to the open position (180°).
2. Attach the drilling template to the locking cam of the extension. Please note: the additional bogies are located on the left and right sides of the control units closer to the center of the sash at a distance of 10 mm. The template must be used accordingly (see L marking).
3. Drill Ø3 holes for the bogies.
4. Fix with Ø4*22 (or Ø3.9*25) self-tapping screws.

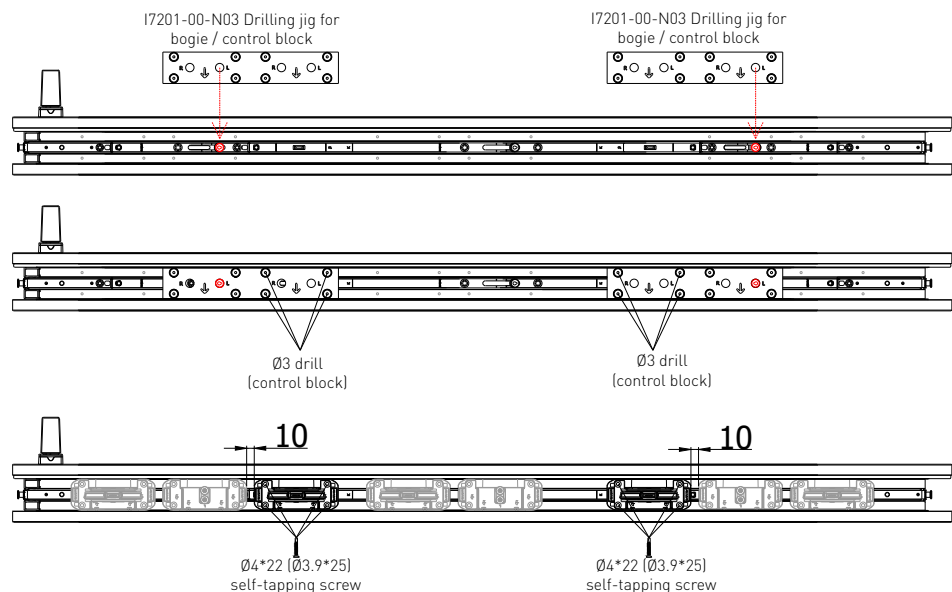



Installation of the bogie and the control block using a drilling jig.
Right opening. Bottom.

1. Rotate a handle in open position (180°).
2. Install drilling jig on the locking pin of extension lock. Pay attention: handle side bogie is from the right side, mullion side bogie is from the left side. Drilling jig has to be used accordingly (see marking R).
3. Drill hole Ø3 for bogie and control block.
4. Fix with screws Ø4*22 (alternatively Ø3,9*25).

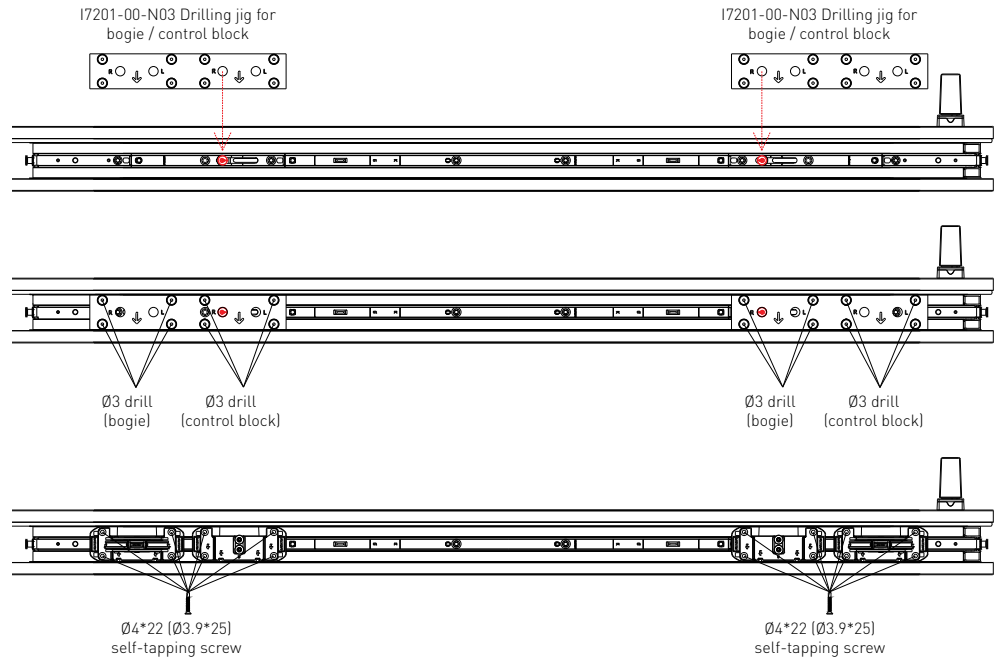

Additional bogie from SRW > 1110

1. Rotate a handle in open position (180°).
2. Install drilling jig on the locking pin of extension lock. Pay attention: handle side bogie is from the right side, mullion side bogie is from the left side. Drilling jig has to be used accordingly (see marking R). Additional bogie has to be placed in the middle of sash (SRW).
3. Drill hole Ø3 for bogie and control block. For additional bogie has to be drilled just for bogie.
4. Fix with screws Ø4*22 (alternatively Ø3,9*25).

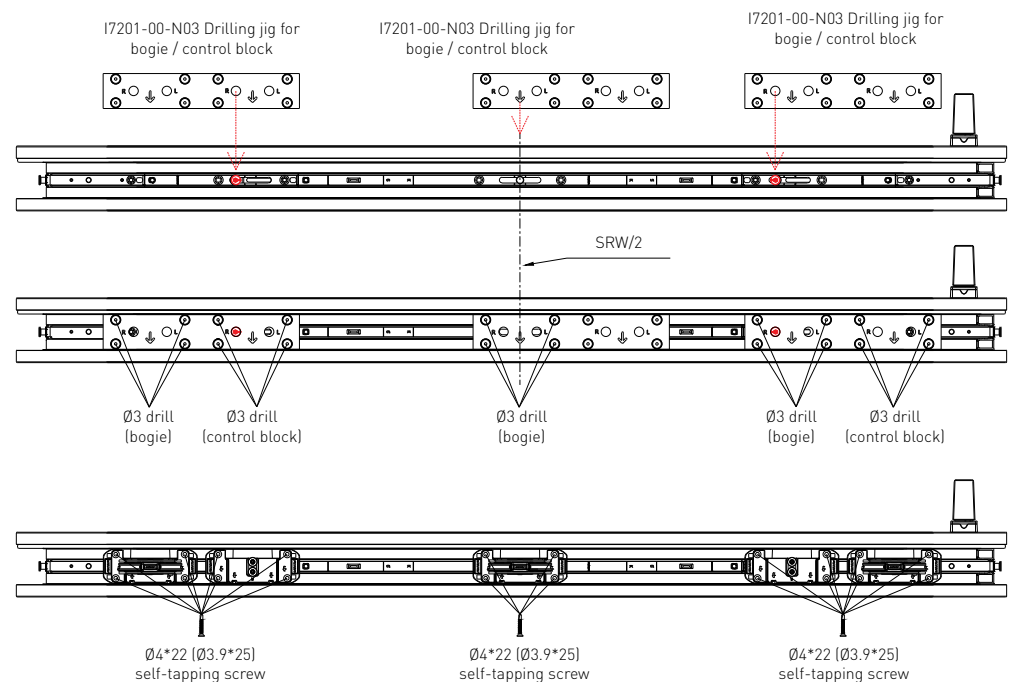



Installation of the bogie and the control block using a drilling jig. Right opening. Bottom.

Additional bogie and control block for SRW > 1310

1. Rotate a handle in open position (180°).
2. Install drilling jig on the locking pin of extension lock. Pay attention: handle side bogie is from the right side, mullion side bogie is from the left side. Handle side bogie is from the right side, mullion side bogie is from the left side. Drilling jig has to be used accordingly (see marking R).
3. Drill hole Ø3 for bogie and control block.
4. Fix with screws Ø4*22 (alternatively Ø3,9*25).

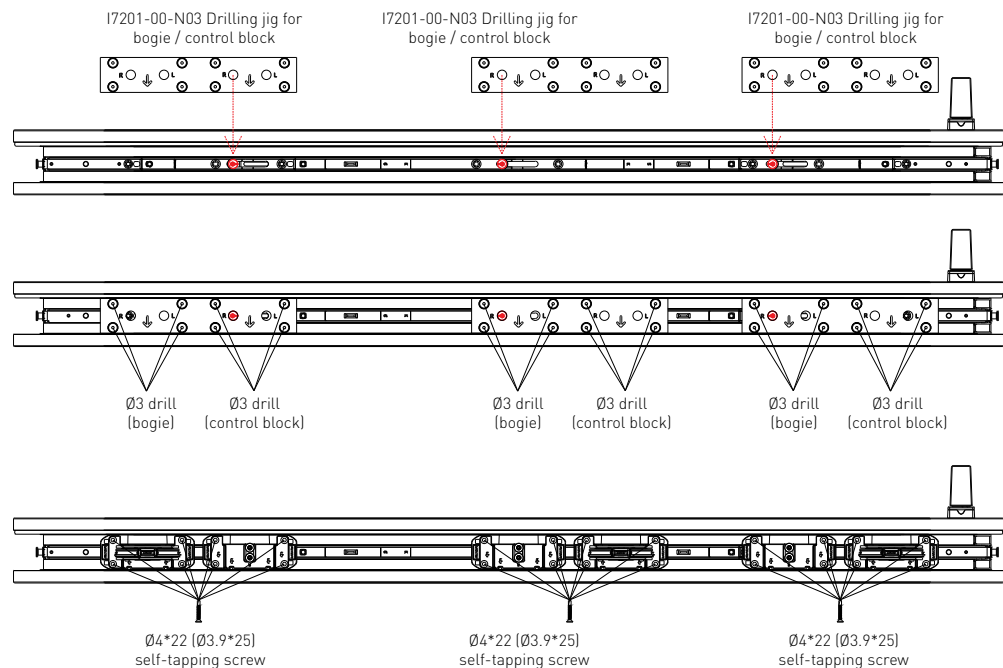

Additional bogie and control block for SRW > 1790

1. Turn the handle to the open position (180°).
2. Attach the drilling template to the locking cam of the extension. Please note: the additional bogies are located on the left and right sides of the control units closer to the center of the sash at a distance of 10 mm. The template must be used accordingly (see R marking).
3. Drill Ø3 holes for the bogies.
4. Fix with Ø4*22 (or Ø3.9*25) self-tapping screws.

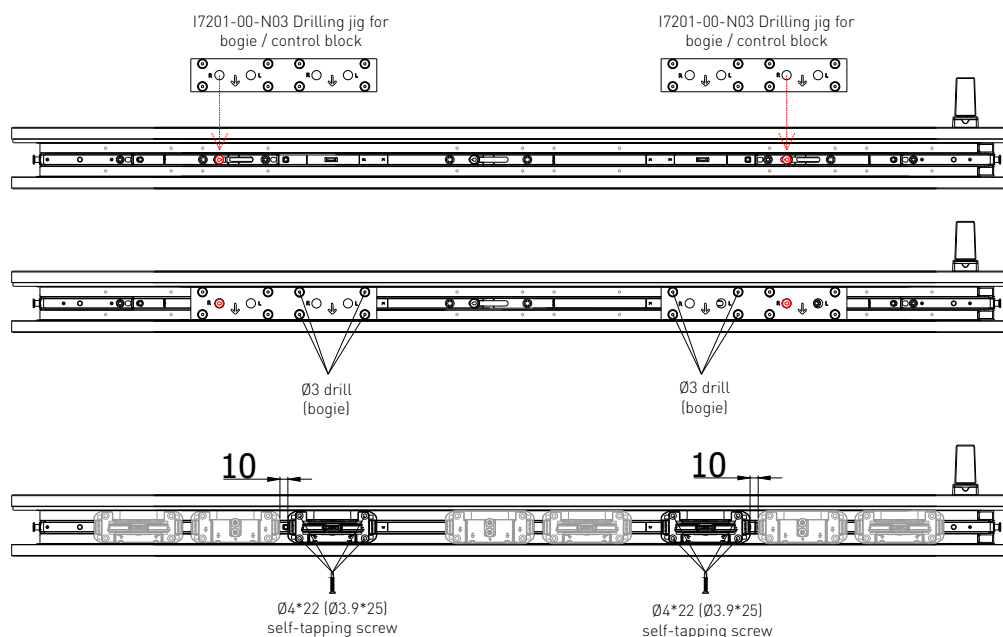

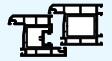

**Installation of the control block using a drilling jig.
Left opening. Top.**

1. Rotate a handle in open position (180°).
2. Install drilling jig on the locking pin of extension lock. Pay attention: Drilling jig has to be used accordingly (see marking L).
3. Drill hole $\varnothing 3$ for control block.
4. Fix with screws $\varnothing 4 \times 22$ (alternatively $\varnothing 3,9 \times 25$).

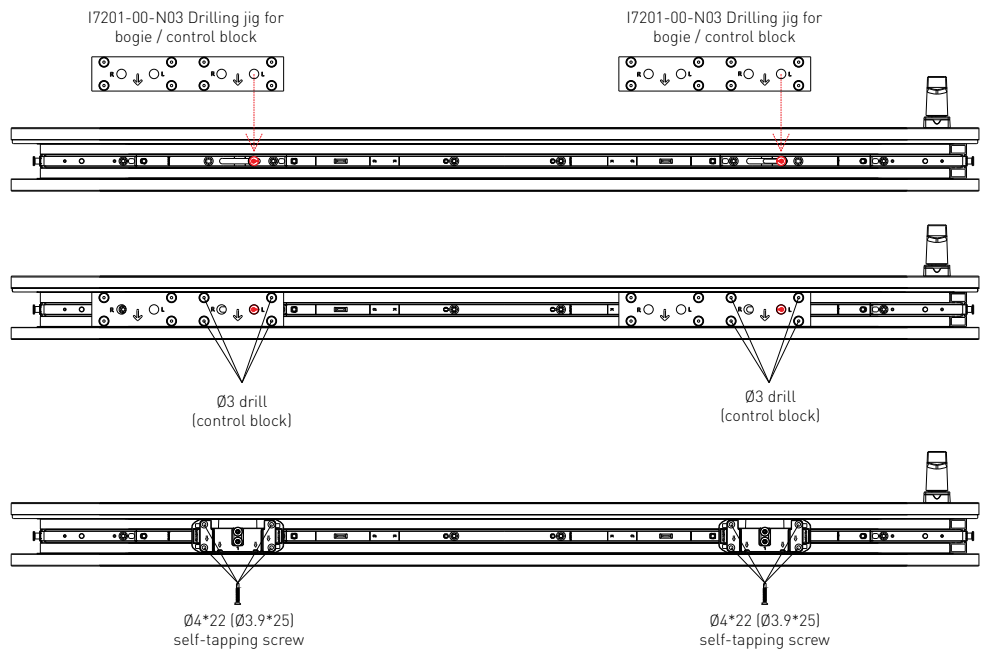

Additional control block from SRW > 1110

1. Rotate a handle in open position (180°).
2. Install drilling jig on the locking pin of extension lock. Pay attention: Drilling jig has to be used accordingly (see marking L).
3. Drill hole $\varnothing 3$ for control block.
4. Fix with screws $\varnothing 4 \times 22$ (alternatively $\varnothing 3,9 \times 25$).

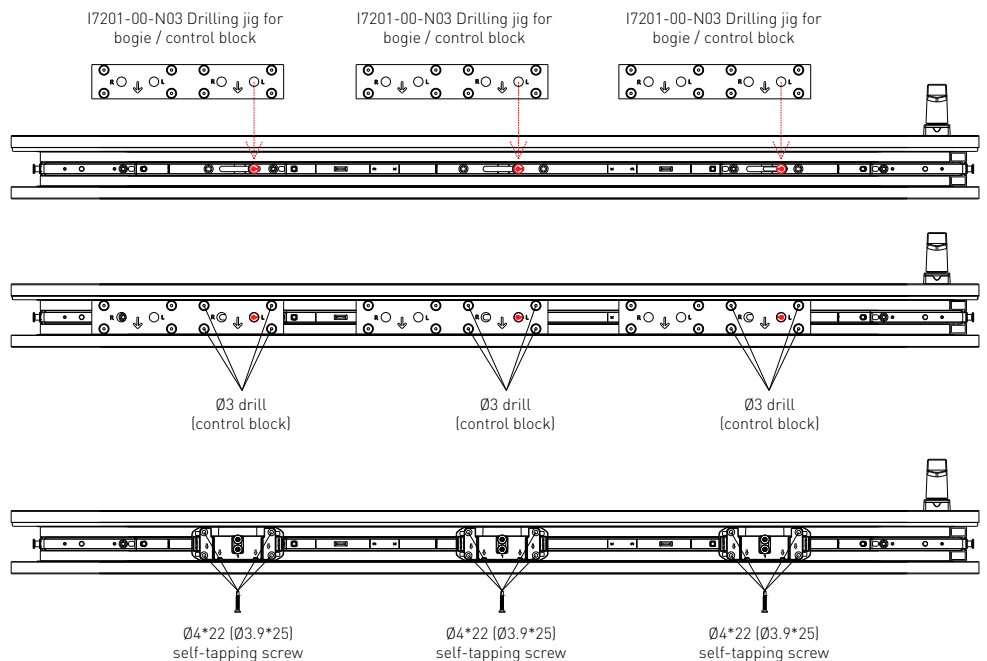



Installation of the control block using a drilling jig. Right opening. Top.

1. Rotate a handle in open position (180°).
2. Install drilling jig on the locking pin of extension lock. Pay attention: Drilling jig has to be used accordingly (see marking R).
3. Drill hole $\varnothing 3$ for control block.
4. Fix with screws $\varnothing 4 \times 22$ (alternatively $\varnothing 3,9 \times 25$).

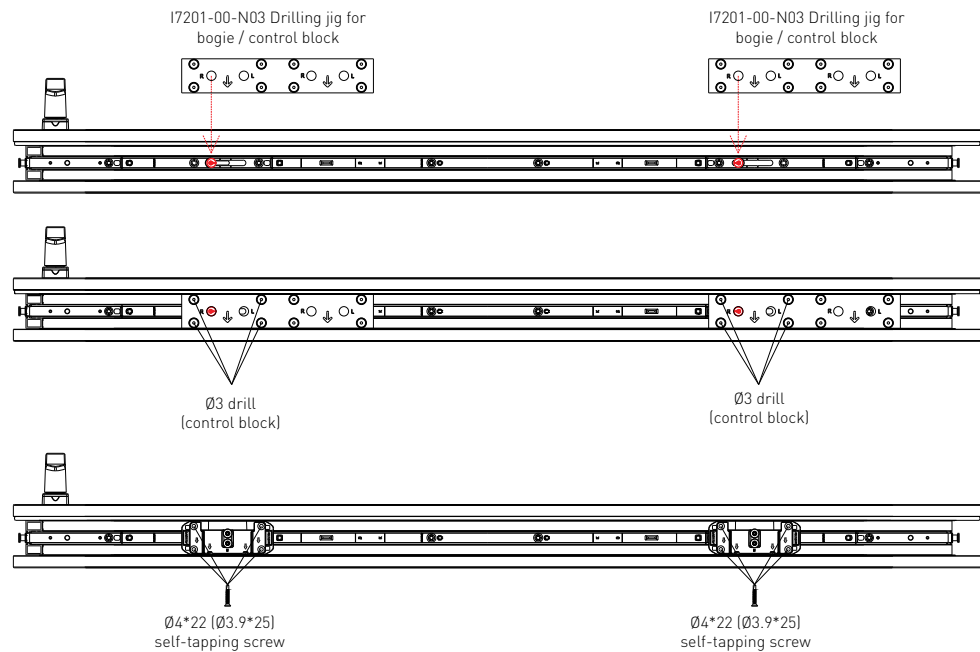

Additional control block from SRW > 1110

1. Rotate a handle in open position (180°).
2. Install drilling jig on the locking pin of extension lock. Pay attention: Drilling jig has to be used accordingly (see marking R).
3. Drill hole $\varnothing 3$ for control block.
4. Fix with screws $\varnothing 4 \times 22$ (alternatively $\varnothing 3,9 \times 25$).

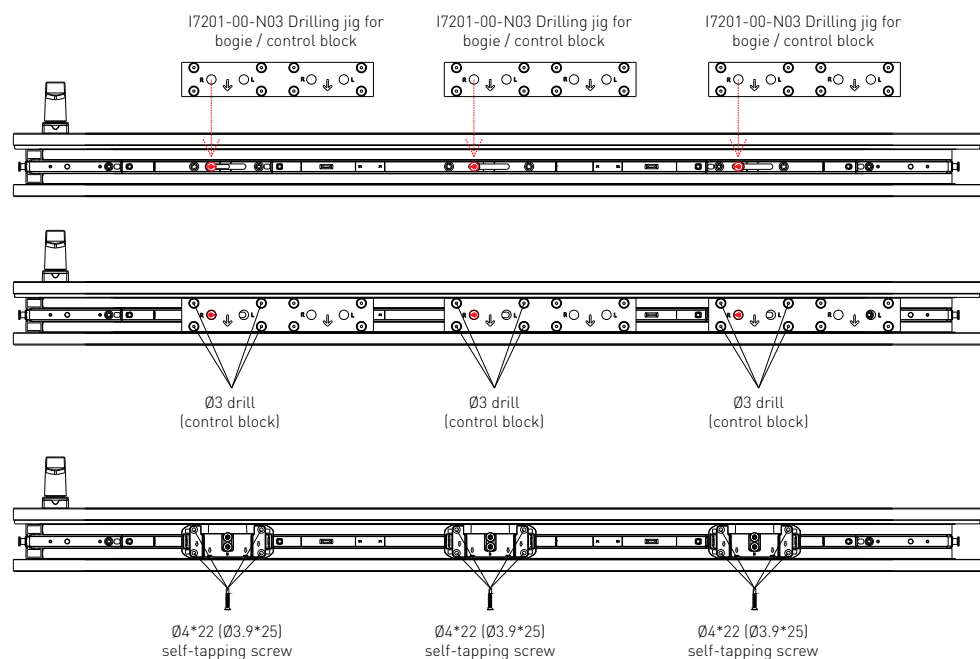

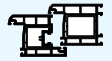

Installation of side lock using a drilling jig (left opening).

1. Rotate a handle in open position (180°).
2. Install drilling jig on the locking pin of corner transmission, extension lock. Pay attention: drilling jig has to be used accordingly (see marking L).
3. Drill hole $\varnothing 3$ for side lock.
4. Drill hole $\varnothing 12$ for locking cam.
5. Fix with screws $\varnothing 4 \times 22$ (alternatively $\varnothing 3,9 \times 25$).
6. Install locking cam.
7. Fix with screw M5x8.

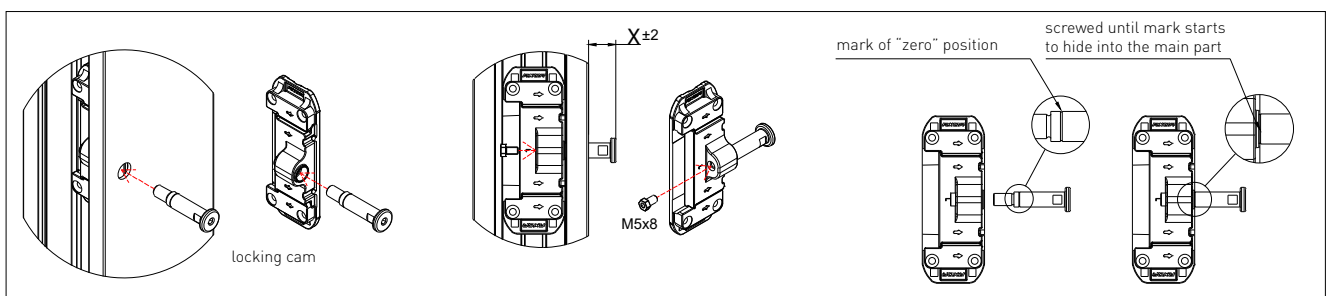
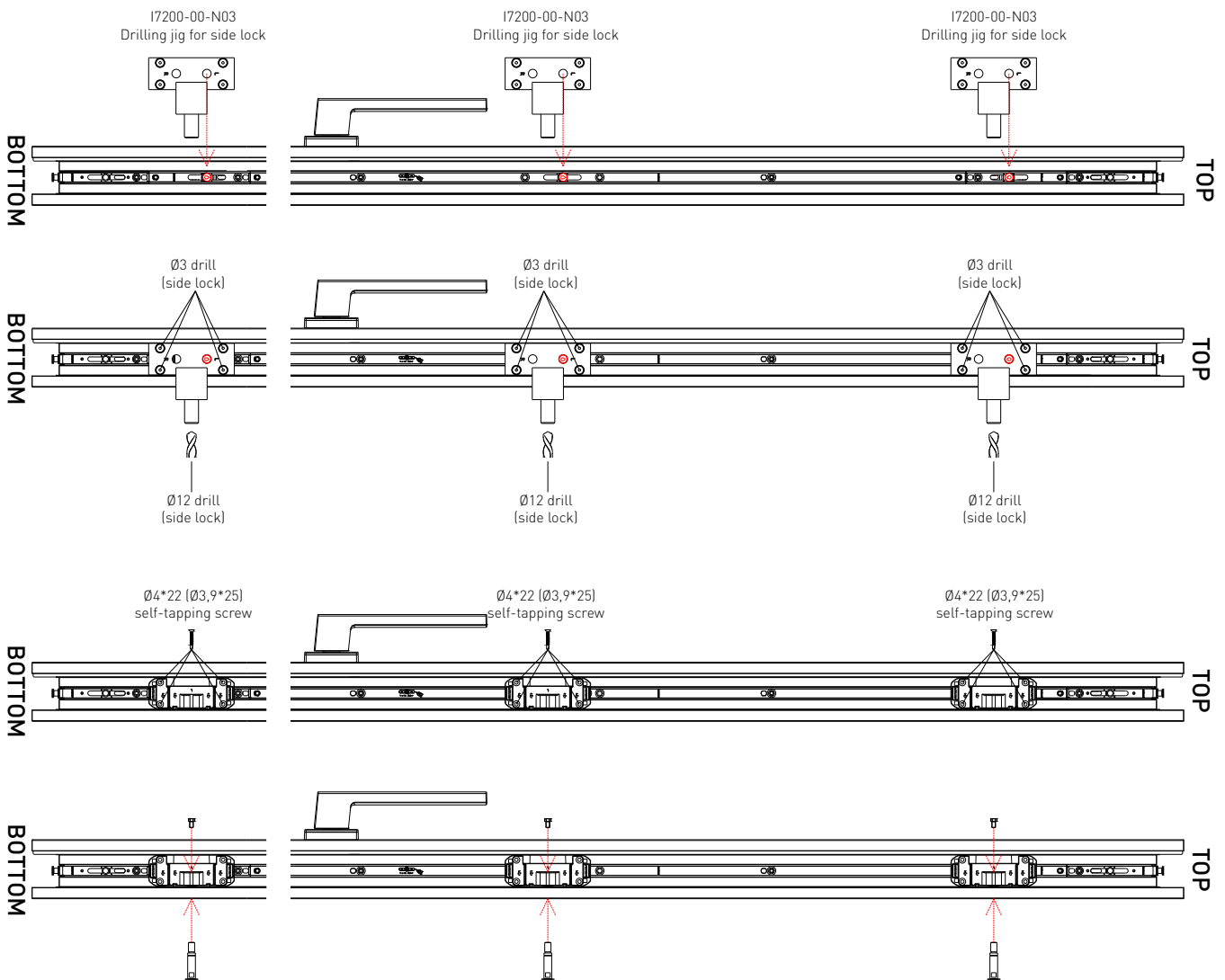



Installation of side lock using a drilling jig (right opening).

1. Rotate a handle in open position (180°).
2. Install drilling jig on the locking pin of corner transmission, extension lock. Pay attention: drilling jig has to be used accordingly (see marking R).
3. Drill hole $\varnothing 3$ for side lock.
4. Drill hole $\varnothing 12$ for locking cam.
5. Fix with screws $\varnothing 4*22$ (alternatively $\varnothing 3,9*25$).
6. Install locking cam.
7. Fix with screw M5x8.

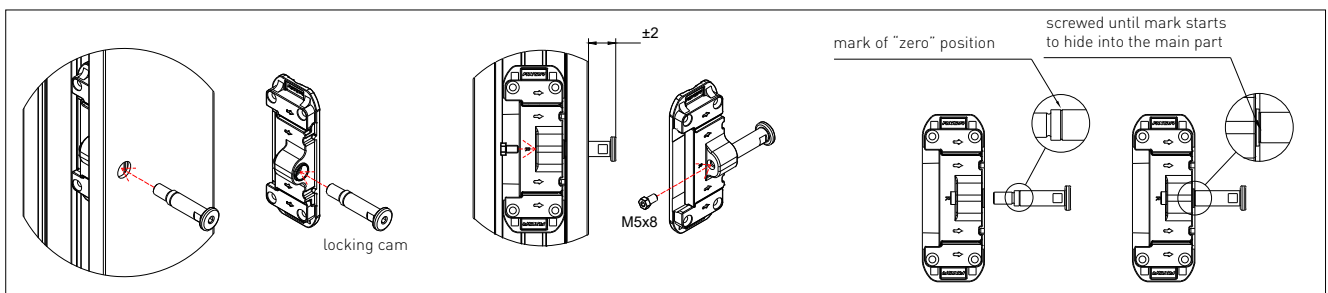
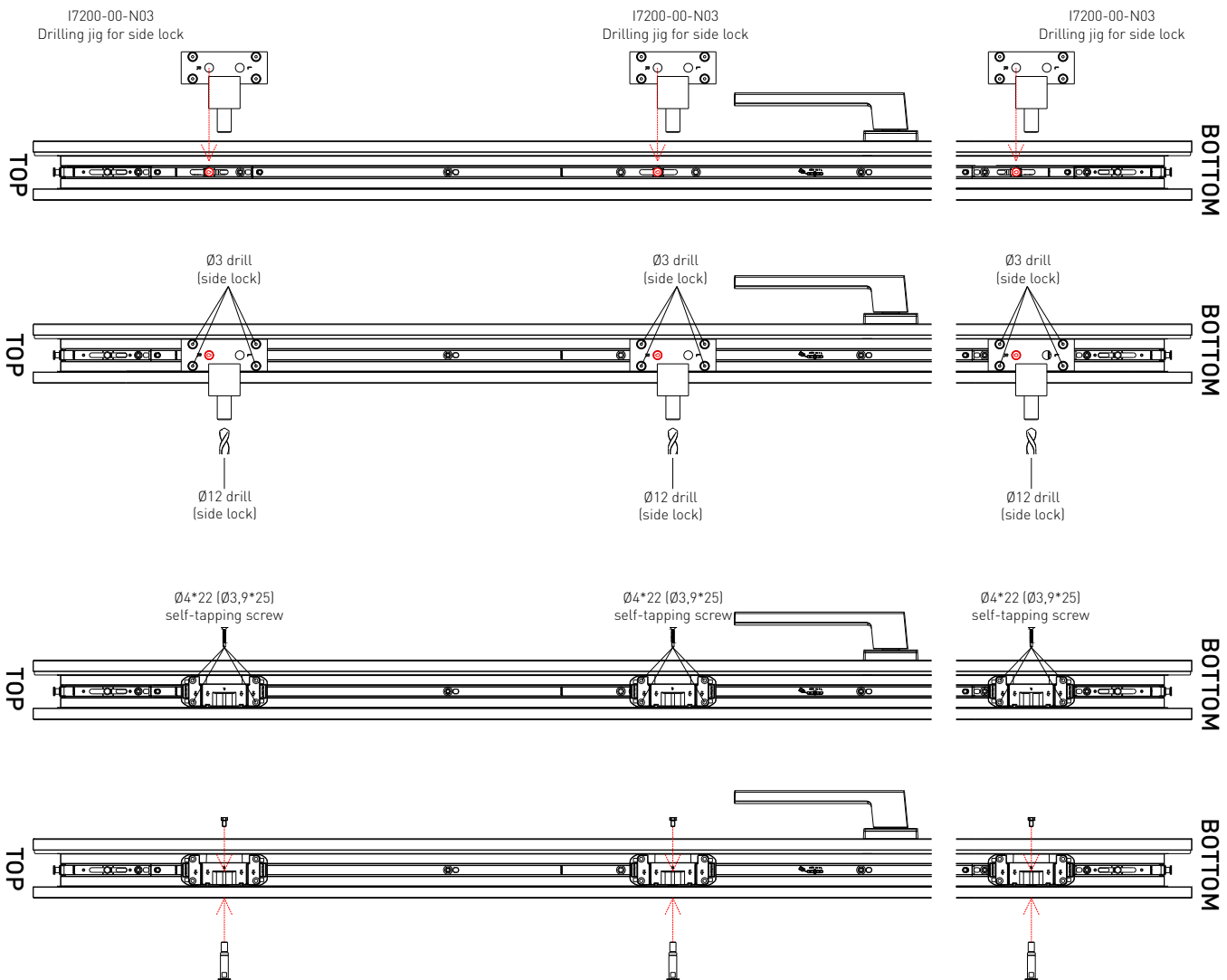

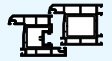

Installation of side locking plate using a drilling jig.

1. Close a sash complitly, rotate a handle in close position (0°).
2. Put a jig on the locking cam of side lock complitly to the end.
3. Move the support part of jig until it contact with mullion.
4. Tight with screws M5x8.
5. Mark the centre of jig.
6. Open and take off a sash.
7. Put a jig again on the mullion in according with mark.
8. Drill holes Ø3 for side locking plate.
9. Fix with screws Ø3,9*38.
10. Install decorative cover.

Install the side locking plate after installing the front dampers.

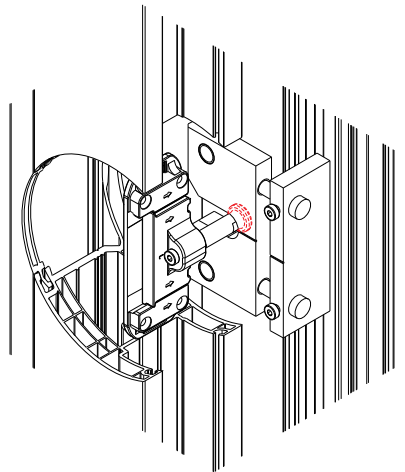

17202-00-N03
Drilling jig for side locking plate

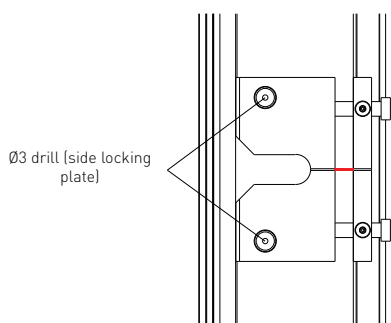
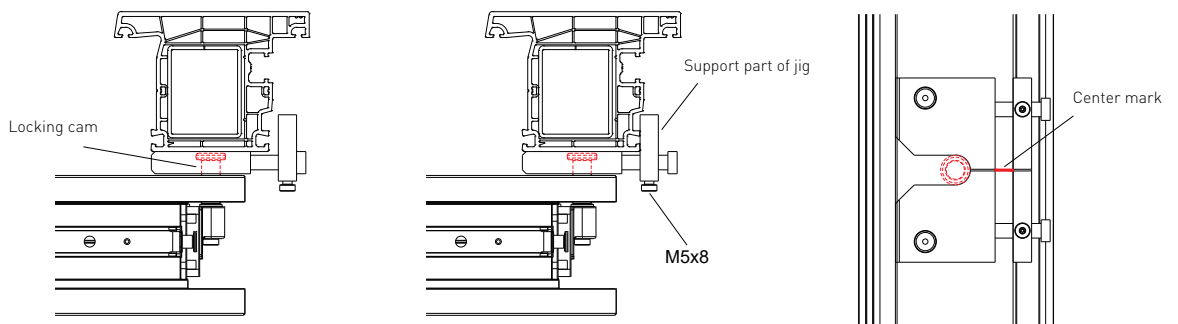

Ø3 drill (side locking plate)

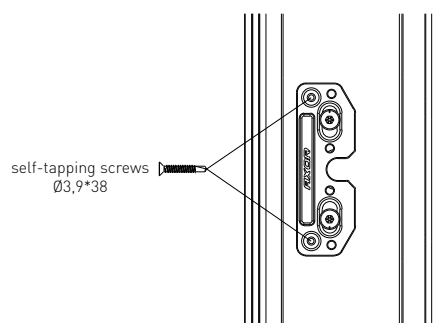

self-tapping screws Ø3,9*38

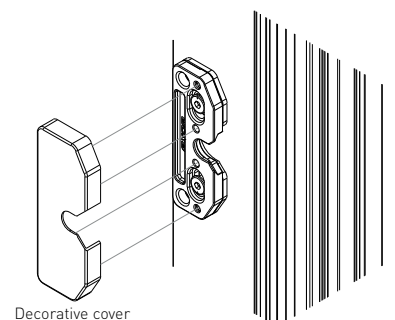

Decorative cover

**Installation of locking plates using a drilling jig. Left opening.
I7012-00-N03 Locking plate for sliding system.**

1. Rotate a handle in open position (180°).
2. Install marking jig on the locking pin of corner transmission, gear. Pay attention: marking jig has to be used accordingly (see marking L).
3. Close the sash with small effort (hit). In result on frame adapter will be markings from pins of jig.
4. Drill hole Ø3 for locking plate according to marking.
5. Fix with screws Ø4*22 (alternatively Ø3,9*25).

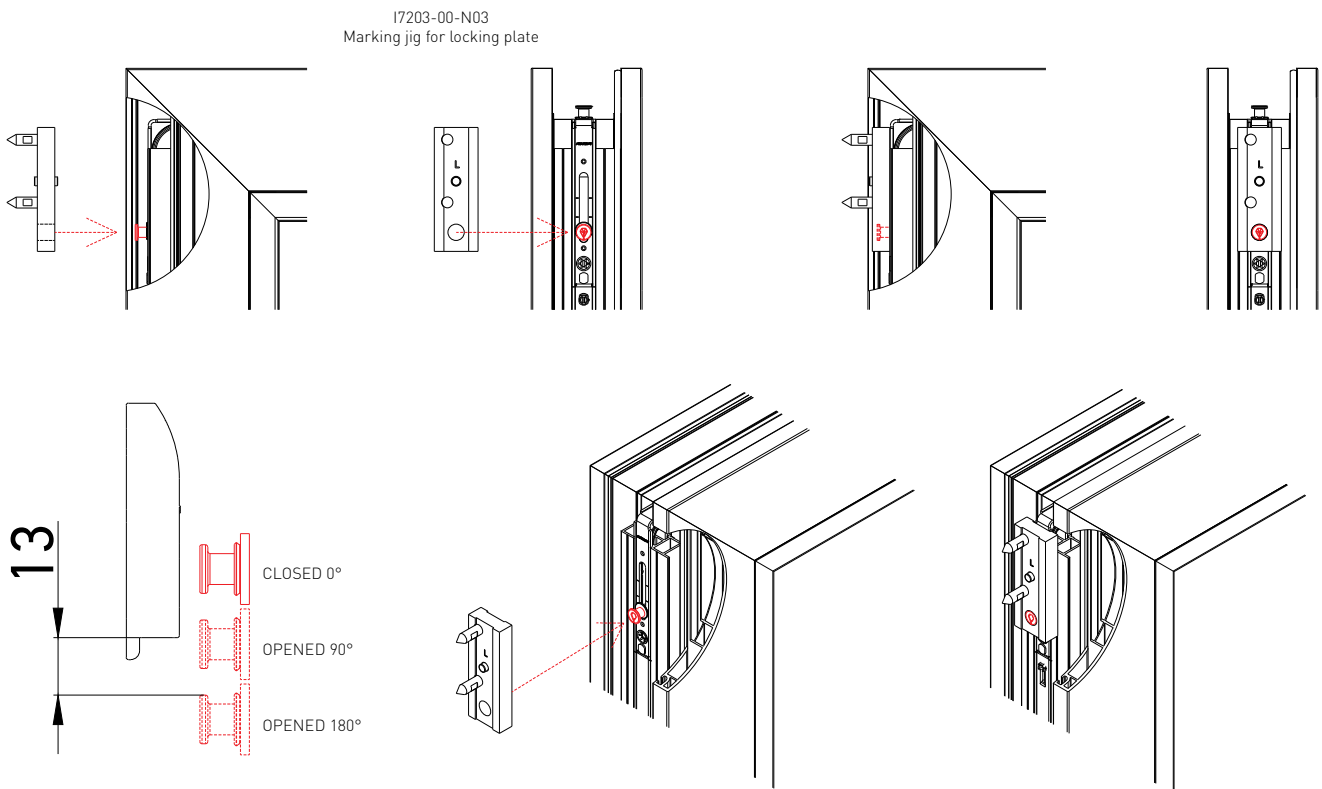

**Installation of locking plates using a drilling jig. Right opening.
I7012-00-N03 Locking plate for sliding system.**

1. For right opening has to be unscrewed pins of marking jig.
2. Rotate marking jig.
3. Screw again on the right side of jig base (see marking R).
4. Repeat the steps as for left opening.

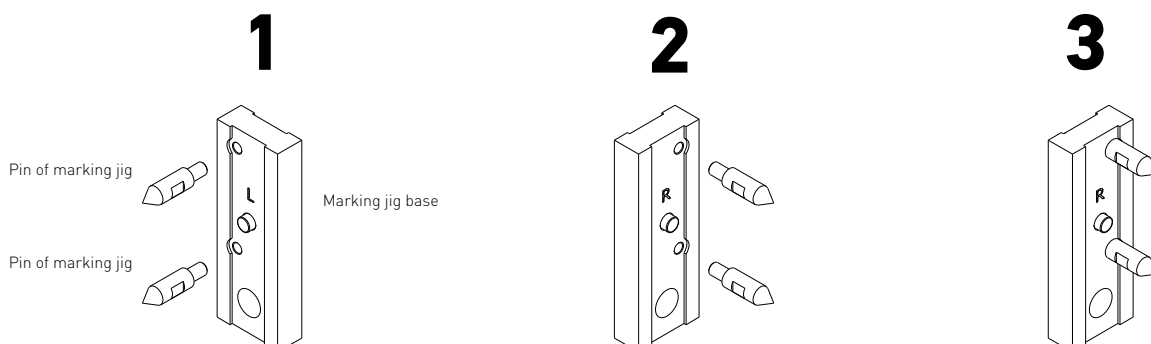

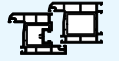

Installation of locking plate incorrect operation device.

Left/right opening.

I7017-00-N03 Locking plate for sliding system, incorrect operation device

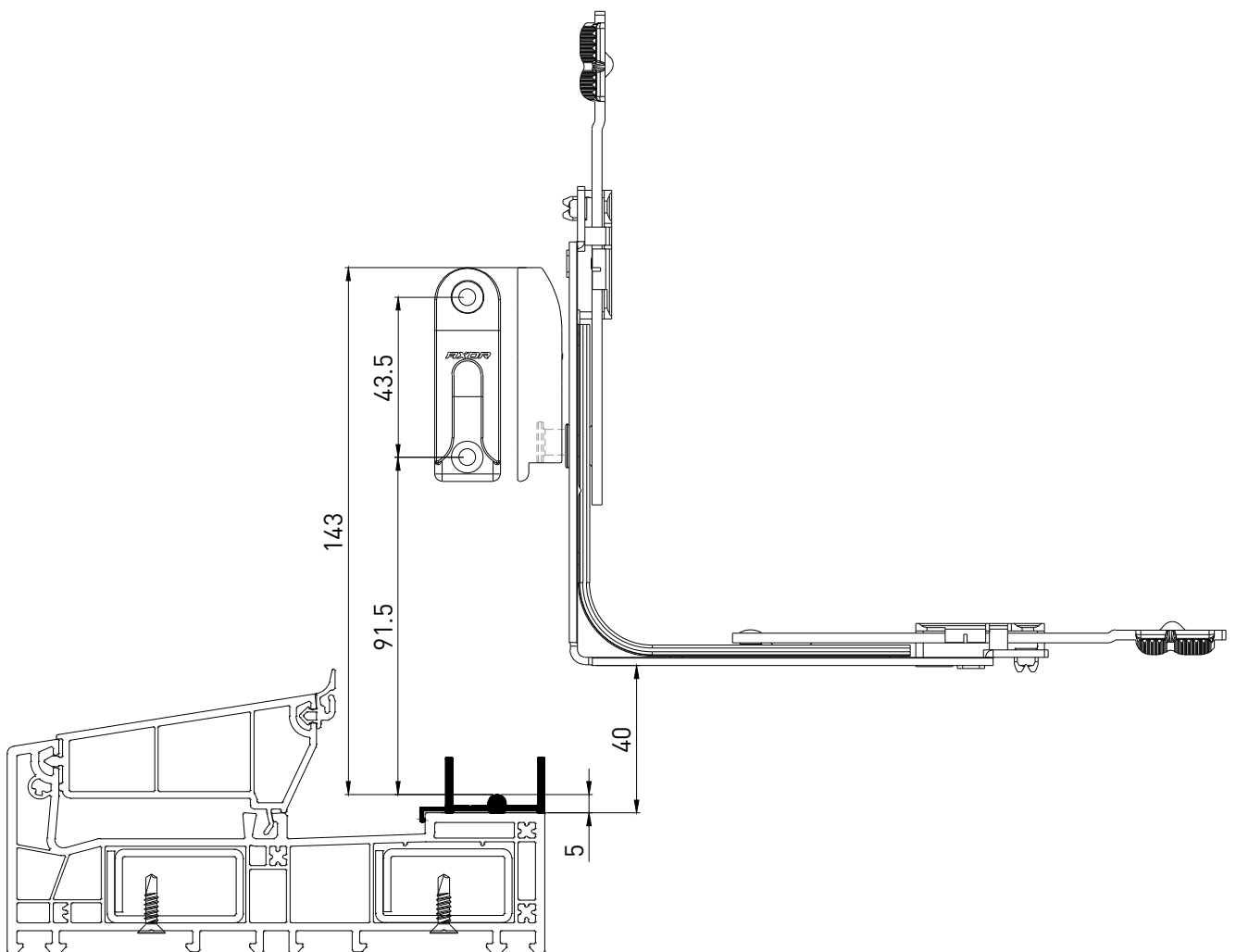

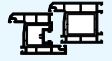

Front damper installation.

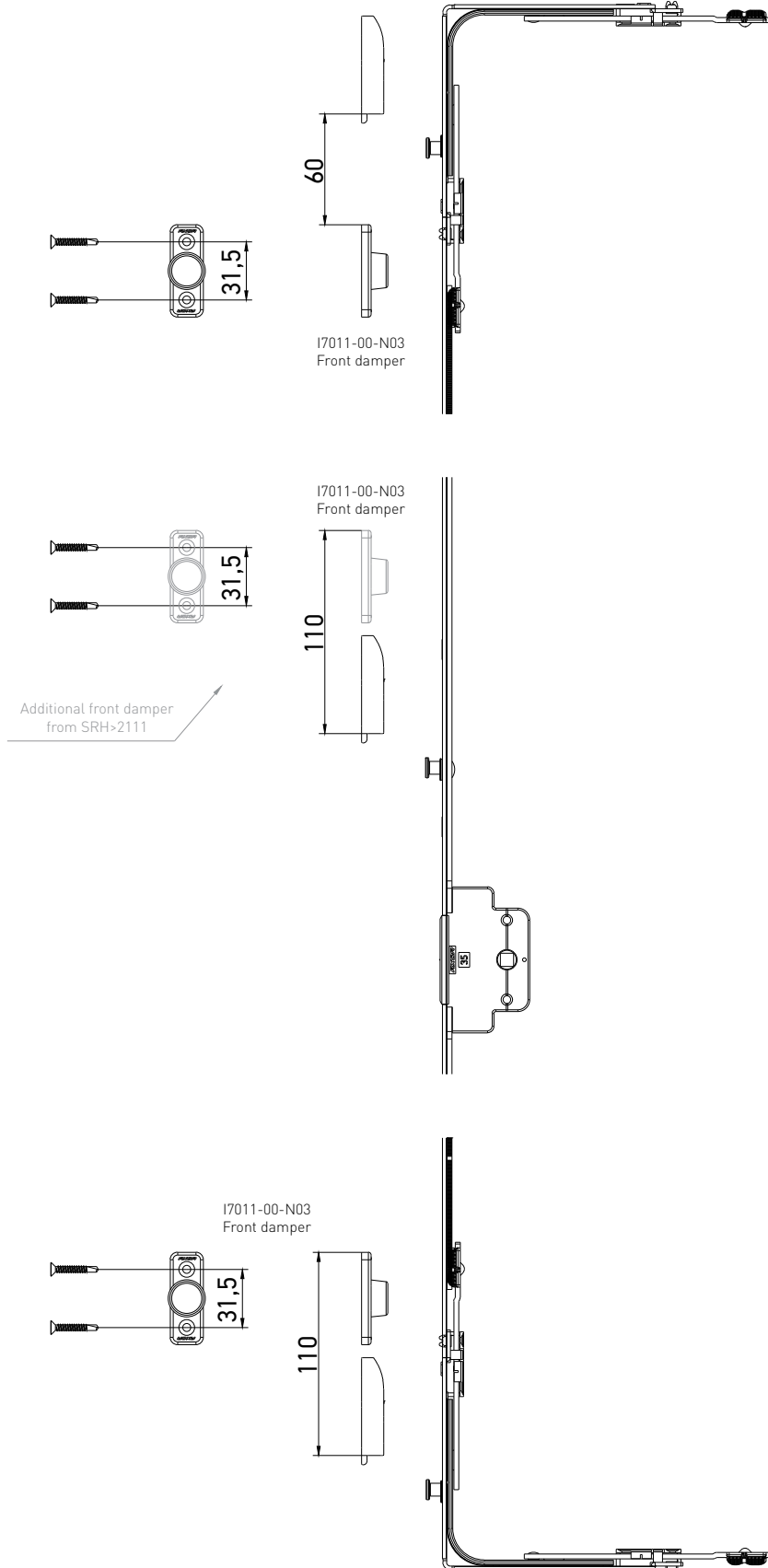

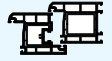

Opened position stopper installation.

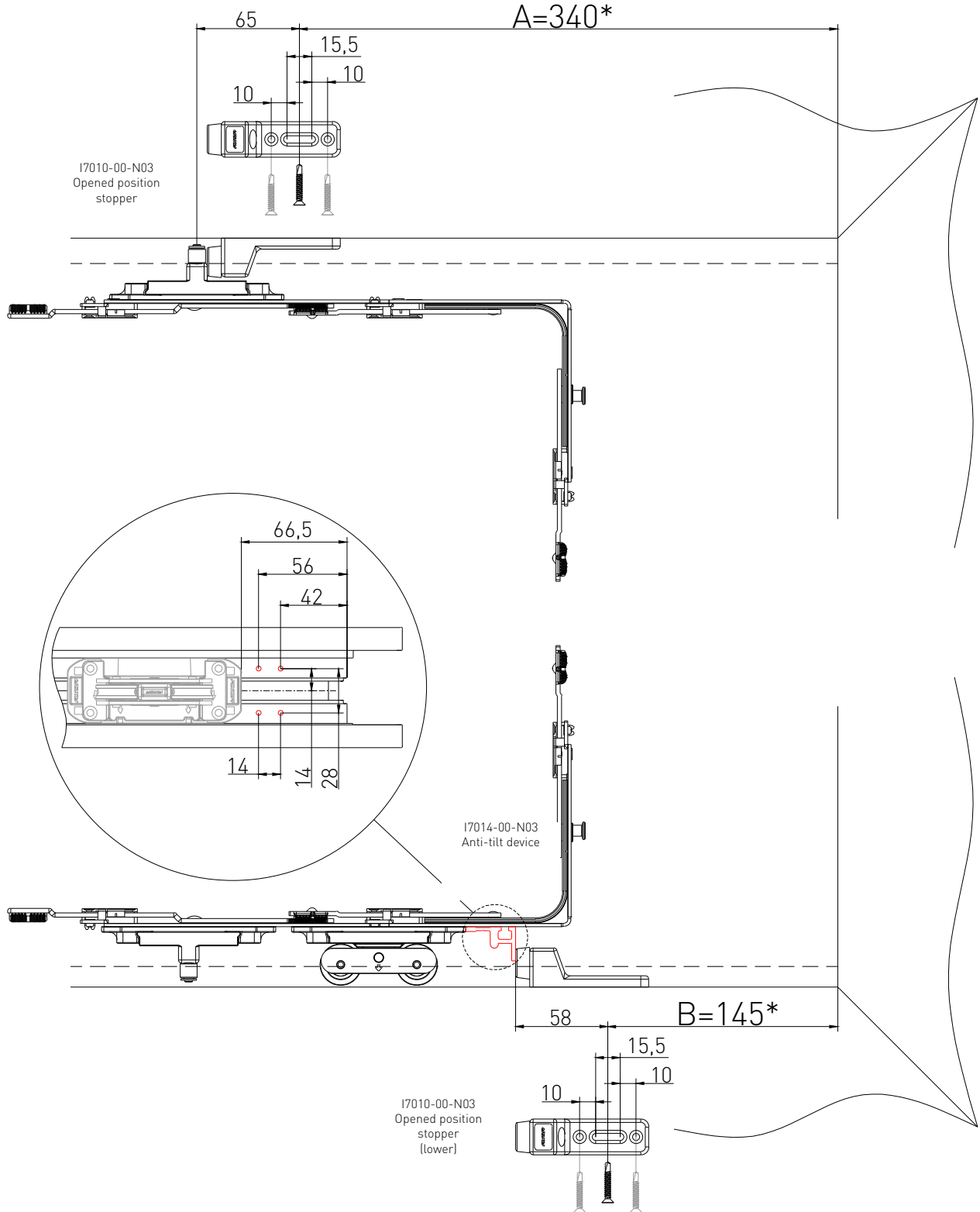

*Should be set individually (B=A-195).

1. Previously fix with central screw.
2. If needed - adjust position and fix finally with 3 screw.



Cutting of guides

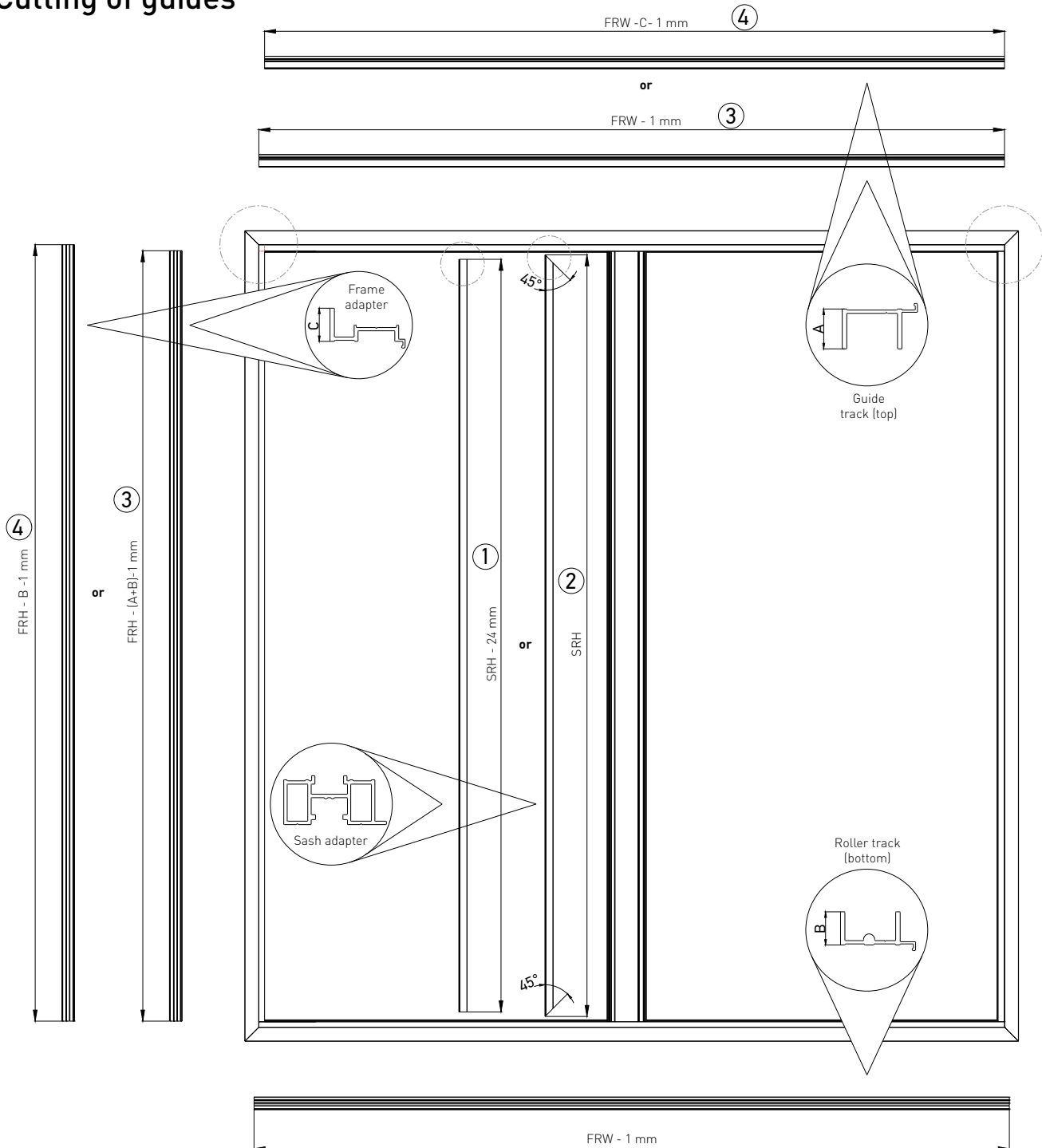

Drilling holes for guides:

Guide track (top)

Roller track (bottom)

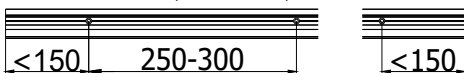

1. Fixing holes $\varnothing 4.5$ mm; chamfers min. $\varnothing 7.5$
2. The distance between holes must be 250-300 mm
3. The distance from the end of guide to first hole max. 150 mm (both sides)

- ① For straight cut, central installation: gap 12 mm from the top and 12 mm from the bottom.
- ② For angular cut, central installation: no gap from the top and from the bottom (face part).
- ③ Inner installation of frame adapter (between top and bottom tracks).
- ④ Combined installation of frame adapter (between top and bottom tracks).

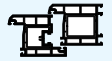

Sash adapter

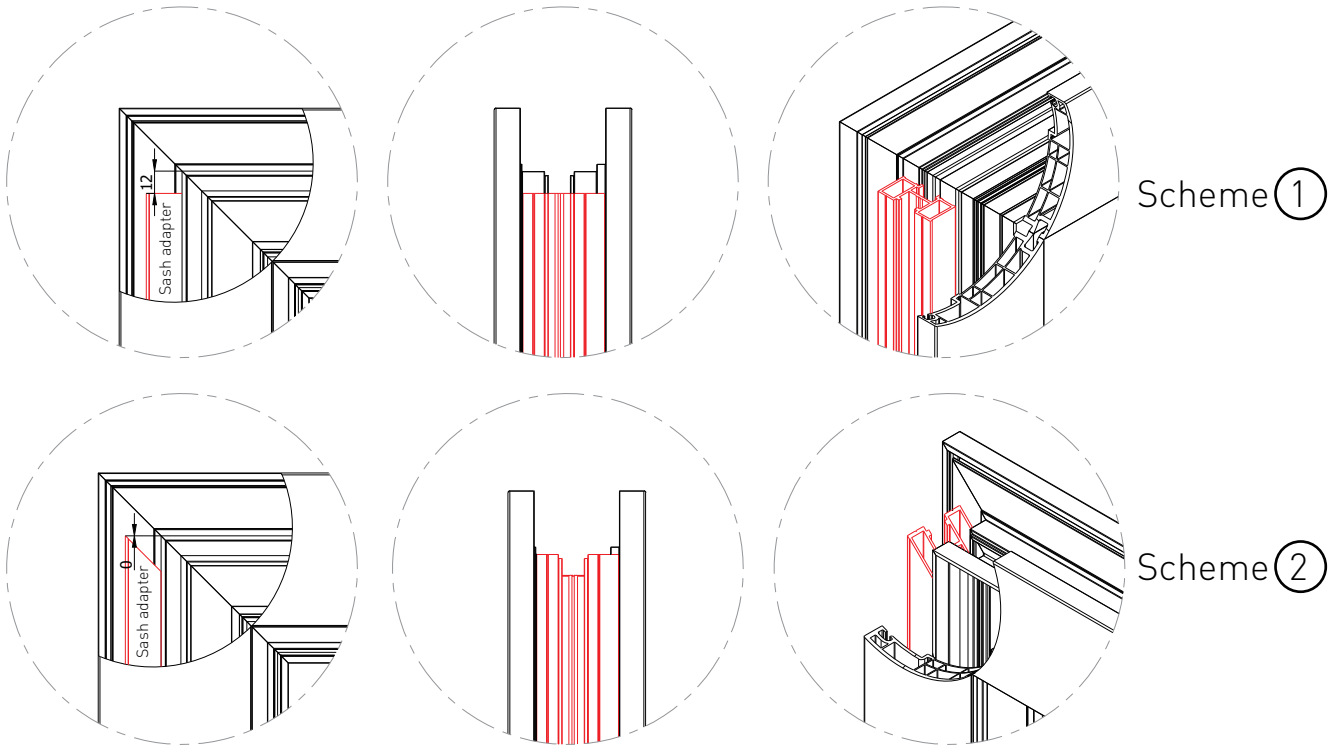

Drilling holes for Sash adapter:

1. The first upper and lower fixing screws of the sash adapter must be located no closer than 200 mm from the sash rebate.

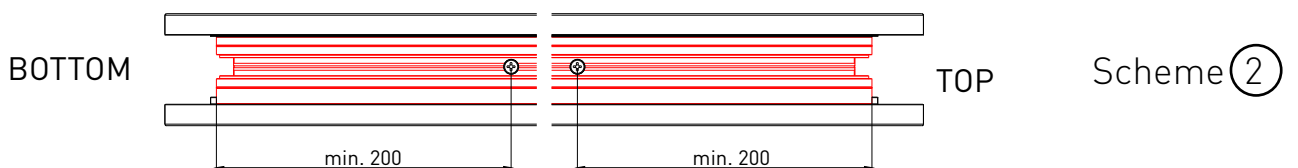
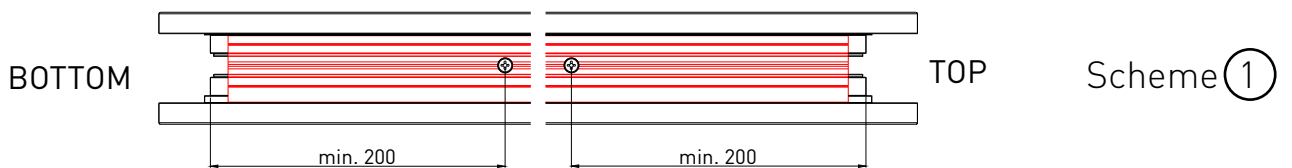

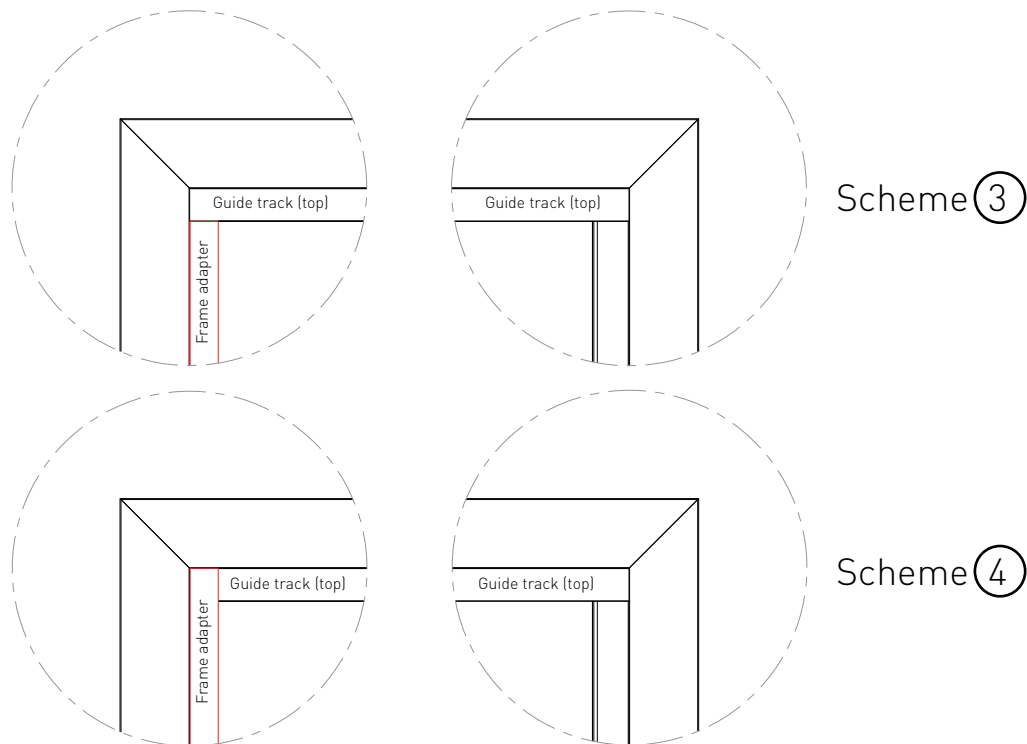
**Frame adapter**

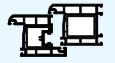

Hardware installation (position of the handle in the center)

Scheme 1

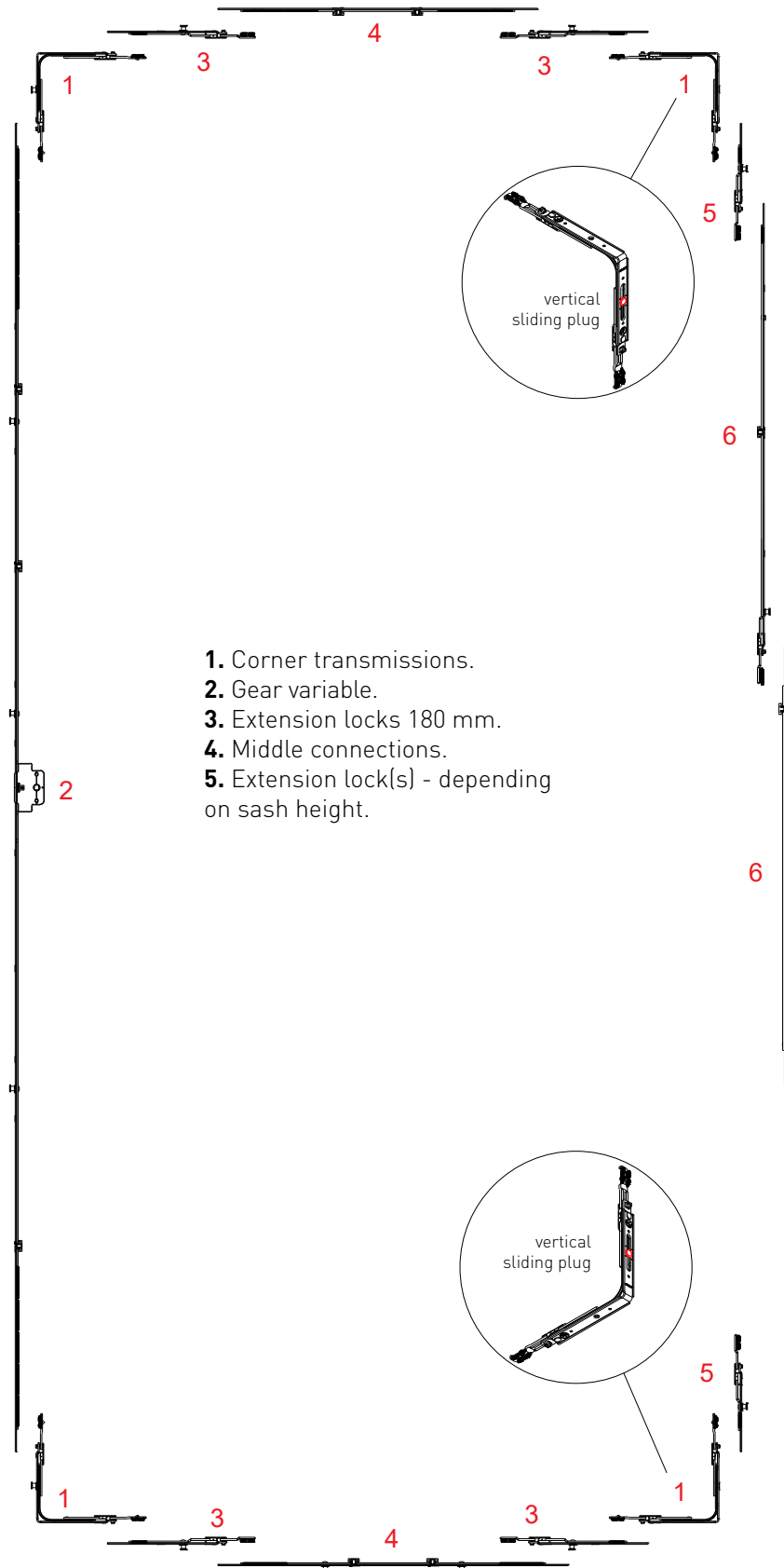

SMART GT

**Hardware installation (handle position G=1000)
Scheme 1**

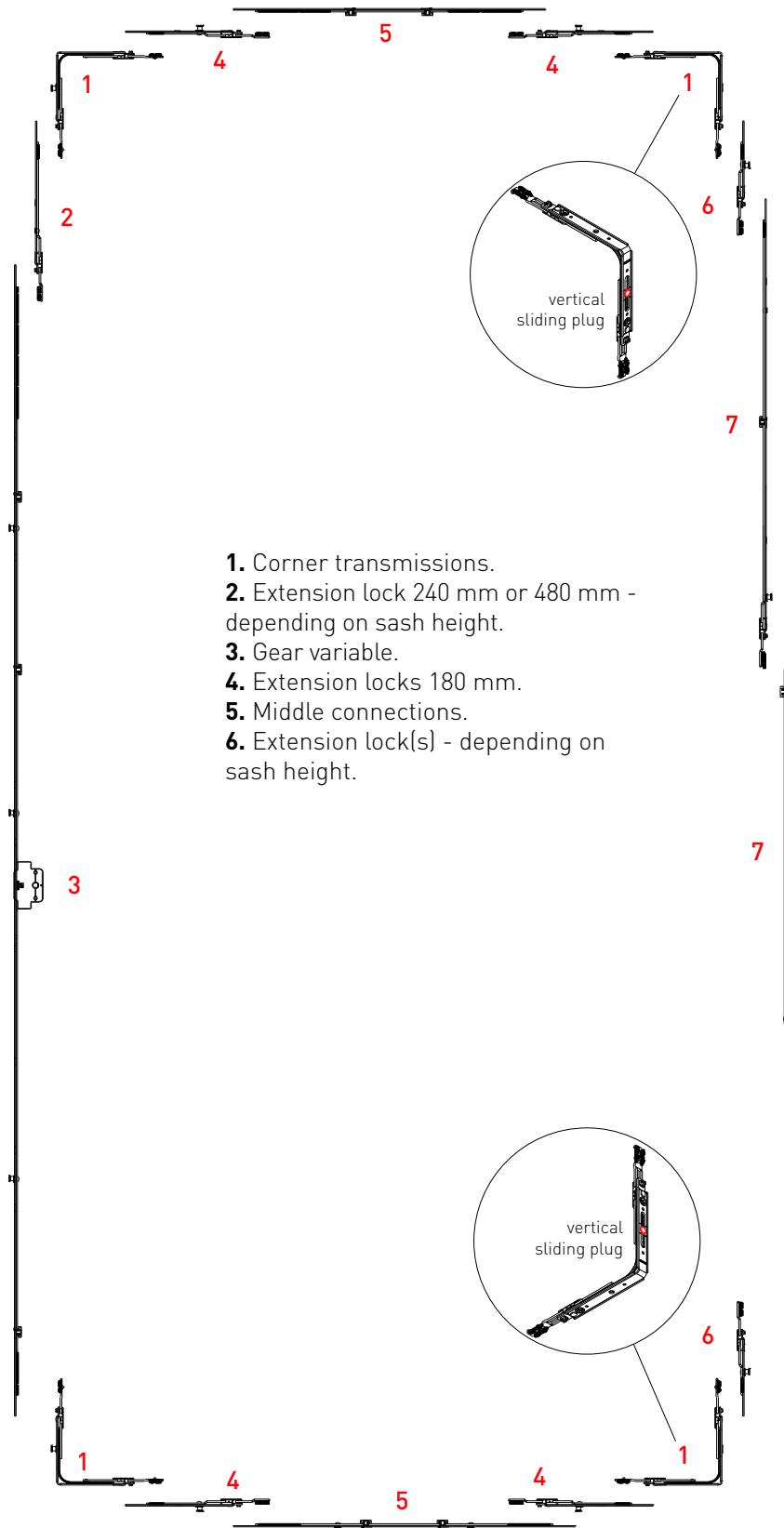

- 1. Corner transmissions.
- 2. Extension lock 240 mm or 480 mm - depending on sash height.
- 3. Gear variable.
- 4. Extension locks 180 mm.
- 5. Middle connections.
- 6. Extension lock(s) - depending on sash height.

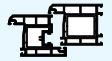

Hardware installation (position of the handle in the center)
Scheme 2

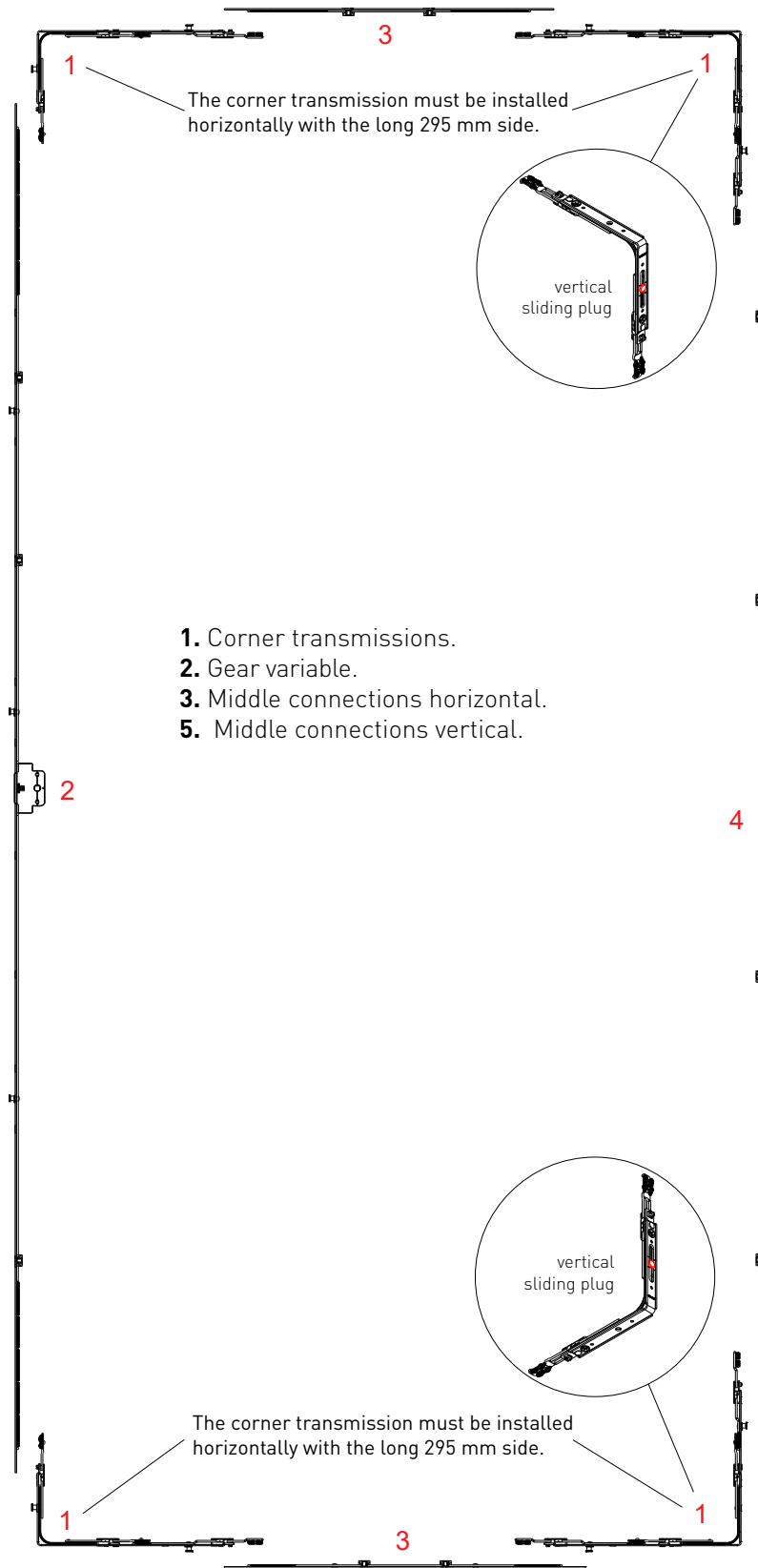

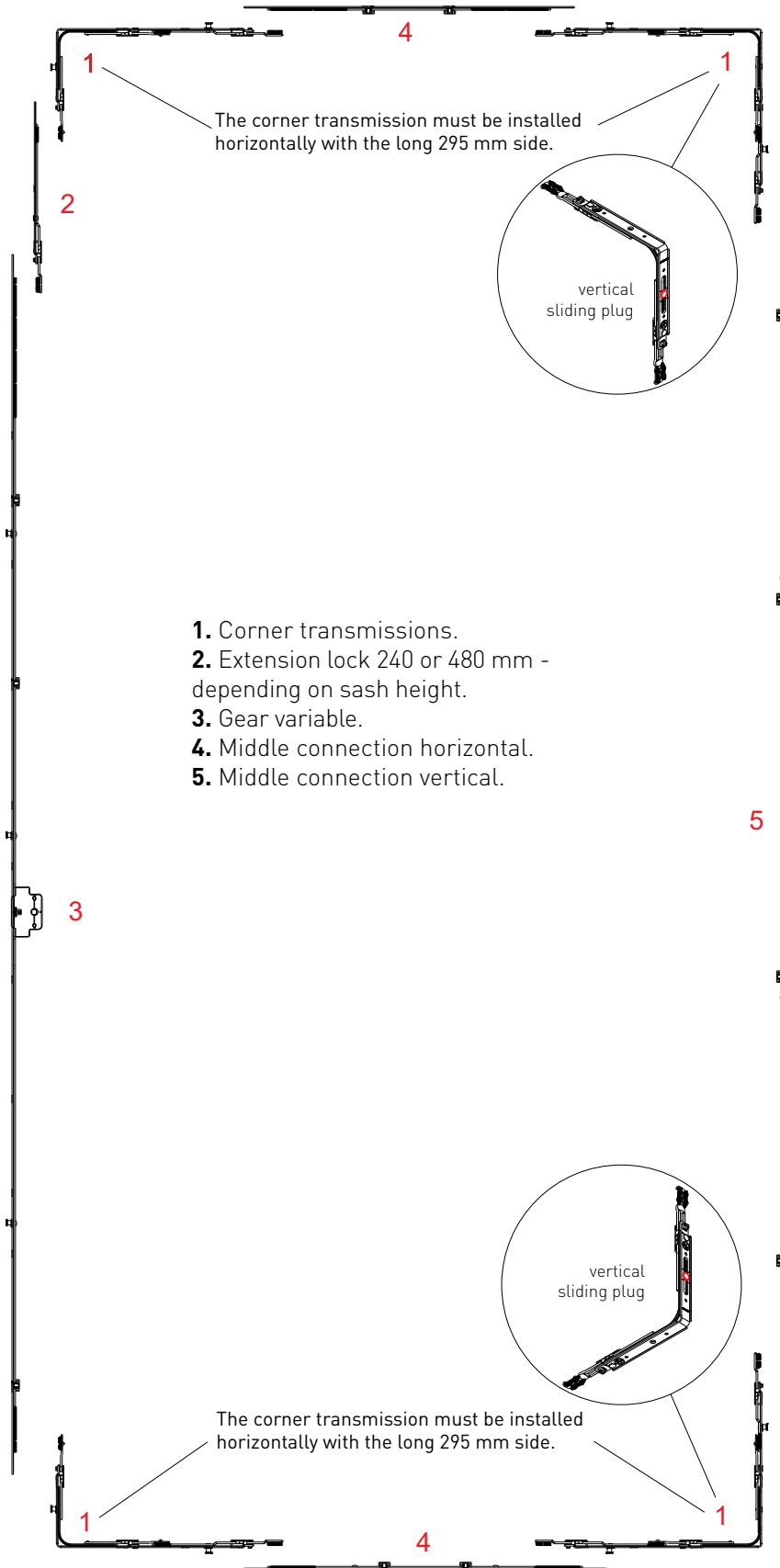
SMART GT**Hardware installation (handle position G=1000)
Scheme 2**

Milling diagrams for the sash end cap

WDS 76 SL

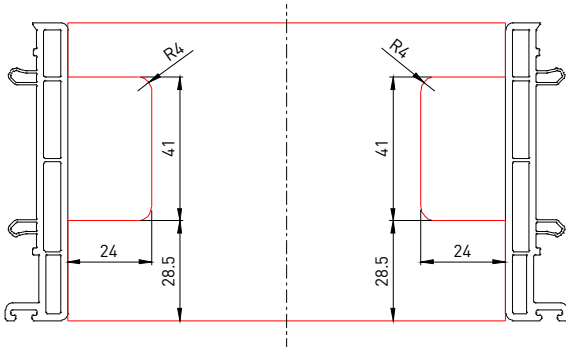

Outside

ALUPLAST neo

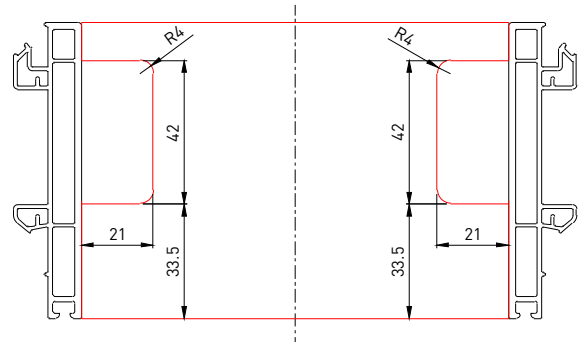

Outside

REHAU Synego (Intelio) Slide

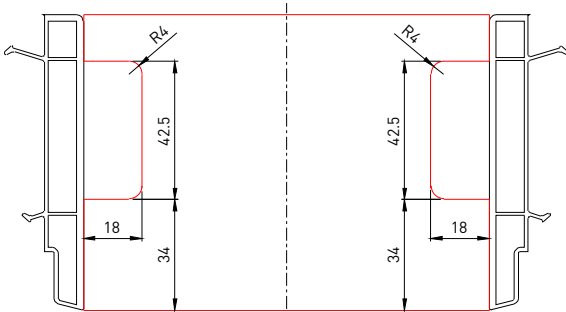

Outside

GEALAN SMOOVIO

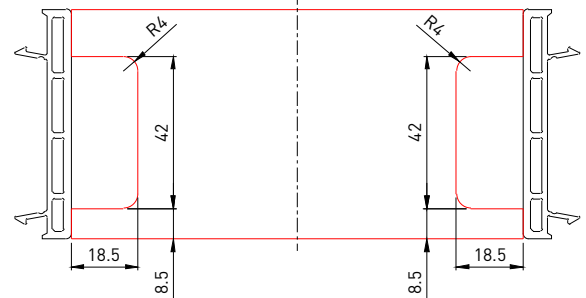

Outside

DECCO SLIDE

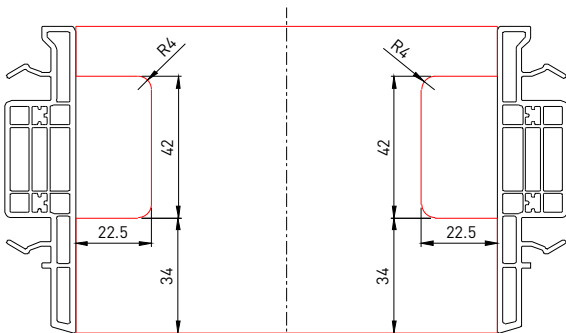

Outside

FRAMEX, VERATEC

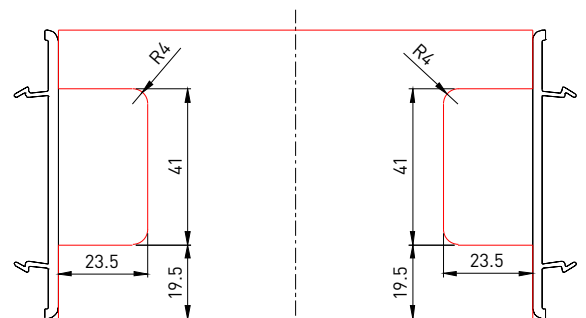

Outside



Aluminium guides

WDS 76 SL, ALUPLAST 70

I9001-00-N03 - 6 M
I9001-01-N03 - 3 M

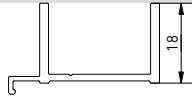

I9002-00-N03 - 6 M
I9002-01-N03 - 3 M

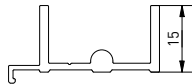

I9003-00-N03 - 3 M
I9003-01-N03 - 6 M

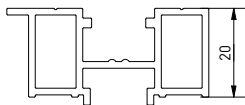

I9004-00-N03 - 3 M
I9004-01-N03 - 6 M

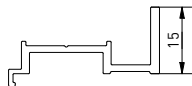

ALUPLAST neo

I9008-00-N03 - 6 M
I9008-01-N03 - 3 M

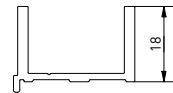

I9006-00-N03 - 6 M
I9006-01-N03 - 3 M

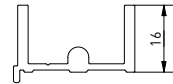

I9009-00-N03 - 3 M
I9009-01-N03 - 6 M

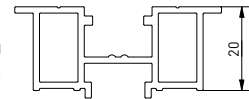

I9010-00-N03 - 3 M
I9010-01-N03 - 6 M

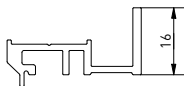

FRAMEX, VERATEC

I9011-00-N03 - 6 M
I9011-01-N03 - 3 M



I9012-00-N03 - 6 M
I9012-01-N03 - 3 M

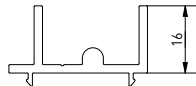

I9003-00-N03 - 3 M
I9003-01-N03 - 6 M

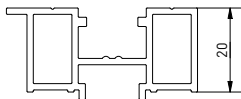

I9013-00-N03 - 3 M
I9013-01-N03 - 6 M

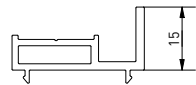

GEALAN SMOOVIO

I9014-00-N03 - 6 M
I9014-01-N03 - 3 M

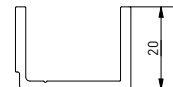

I9015-00-N03 - 6 M
I9015-01-N03 - 3 M



I9016-00-N03 - 3 M
I9016-01-N03 - 6 M

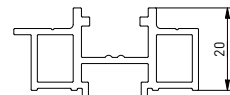

I9017-00-N03 - 3 M
I9017-01-N03 - 6 M

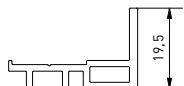

REHAU Synego (Intelio) Slide

I9018-00-N03 - 6 M
I9018-01-N03 - 3 M

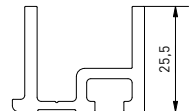

I9007-00-N03 - 6 M
I9007-01-N03 - 3 M

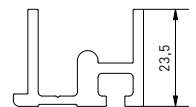

I9019-00-N03 - 3 M
I9019-01-N03 - 6 M

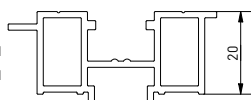

I9020-00-N03 - 3 M
I9020-01-N03 - 6 M

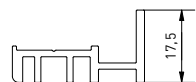

DECCO SLIDE

I9021-00-N03 - 6 M
I9021-01-N03 - 3 M

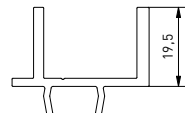

I9005-00-N03 - 6 M
I9005-01-N03 - 3 M

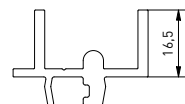

I9022-00-N03 - 3 M
I9022-01-N03 - 6 M

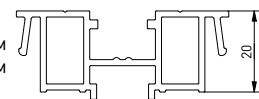

I9023-00-N03 - 3 M
I9023-01-N03 - 6 M



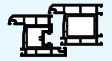

Sash installation

1. Rotate a handle in open position (180°).
2. Put a guide track (top) on control blocks at the top.
3. Install bogies and control blocks with a sash on roller track at the bottom.
4. Install a sash in vertical position. Make sure that the bogies are on the roller track.
5. Fix extrime parts of guide track with screws Ø4*22 (alternatively Ø3.9*25) from both sides.
6. Slide carefully sash to the end and fix guide track completely with screws Ø4*22 (alternatively Ø3,9*25).

Pay attention: it is necessary minimum two people for sash installation!
Otherwise, working staff may be injured or the structure may be damaged!

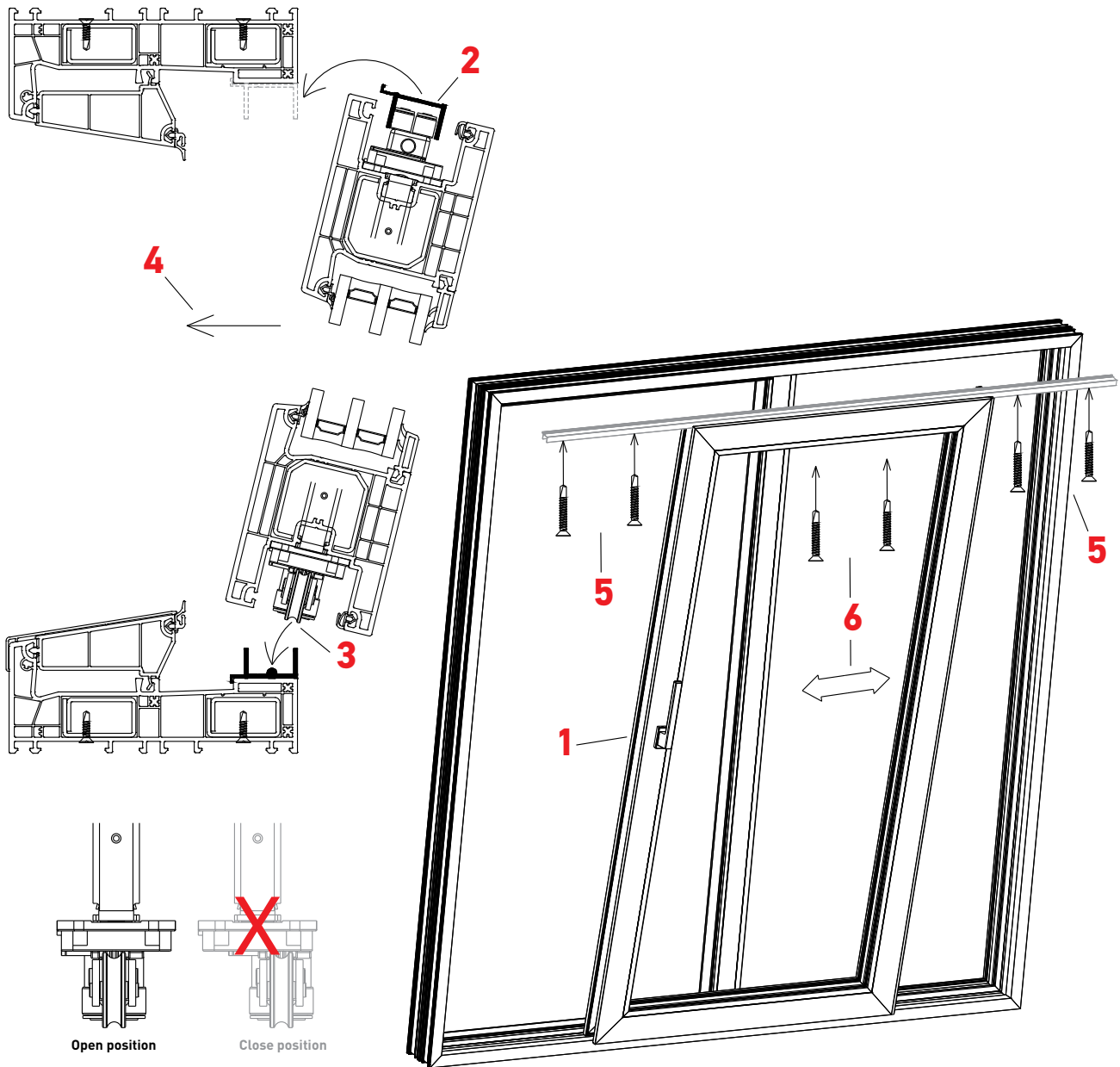



Sash uninstillation

1. Rotate a handle in open position (180°).
2. Unscrew guide track from one side.
3. Slide carefully sash to the end of other side and unscrew guide track completely..
4. Tilt sash and remove guide track.
5. Uninstall sash from roller track.

**Pay attention: it is necessary minimum two people for sash installation!
Otherwise, working staff may be injured or the structure may be damaged!**

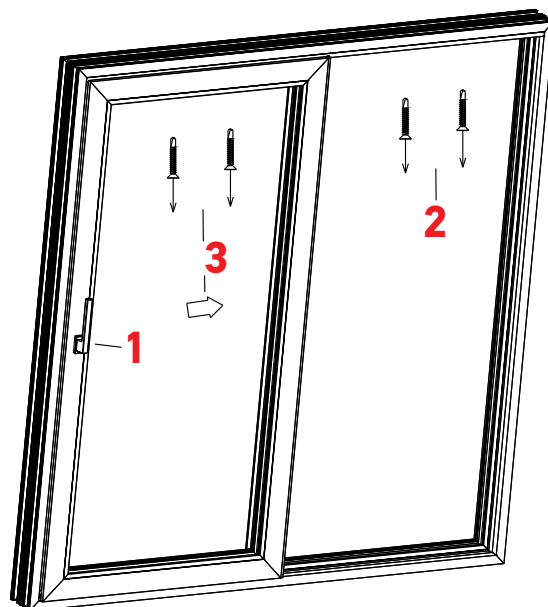
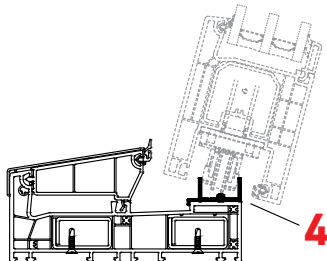
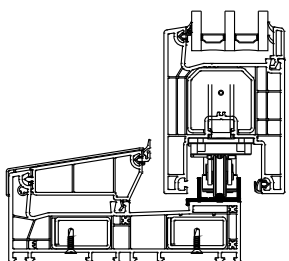
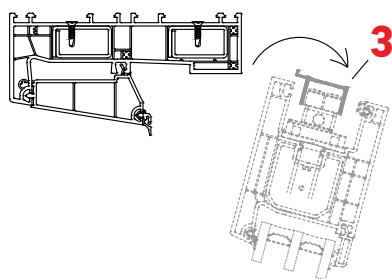
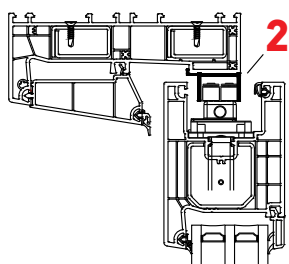

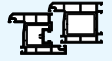
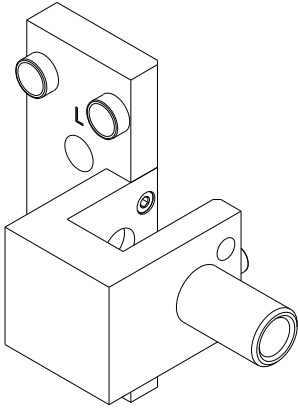
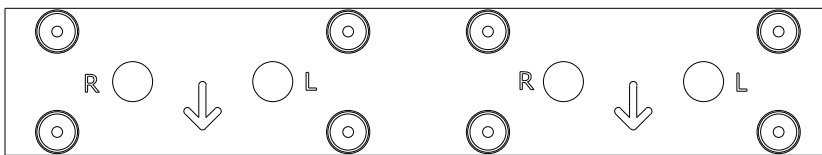
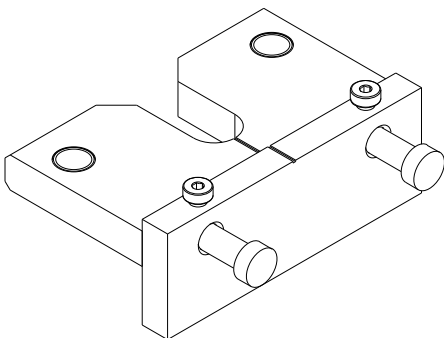
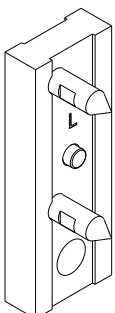
**I7200-00-N03 Drilling jig for side lock****I7201-00-N03 Drilling jig for bogie/control block****I7202-00-N03 Drilling jig for side locking plate****I7203-00-N03 Marking jig for locking plate**



Punching machines



PS100-3-S5-GL20

- Integrated blow out function
- Eccentric cut
- Hydropneumatic drive 0,6 MPa (6 bar)15 kN
- Working pressure, min.....6 bar
- Working pressure, max..... 1 MPa (10 bar)
- Foot switch
- Designed for small up to medium size production



BSD-S5-SHGL20

- Hydropneumatic drive
- Eccentric cut
- Working pressure..... 6-10 bar
- Operating pressure6 bar
- Matrix28 kN
- Push rod18 kN
- Maximum pressure 10 bar
- Foot switch

The rulers

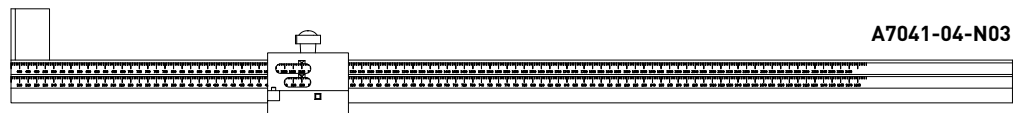

A7041-04-N03

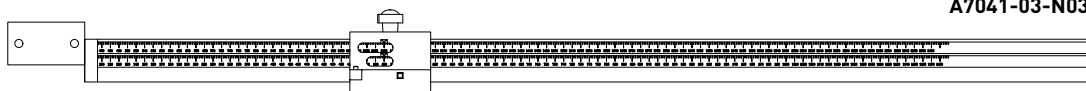

A7041-03-N03

Description	Part No.
Punching machine BSD-"S5-SHGL20, left with foot control	BSD-S5-SHGL20
Punching machine BS-Multi-MAX PS100 with foot control	PS100-3-S5-GL20
The ruler BSD-S5-SHGL20	A7041-03-N03
The ruler PS100-3-S5-GL20	A7041-04-N03

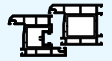

Side locking plate adjustment

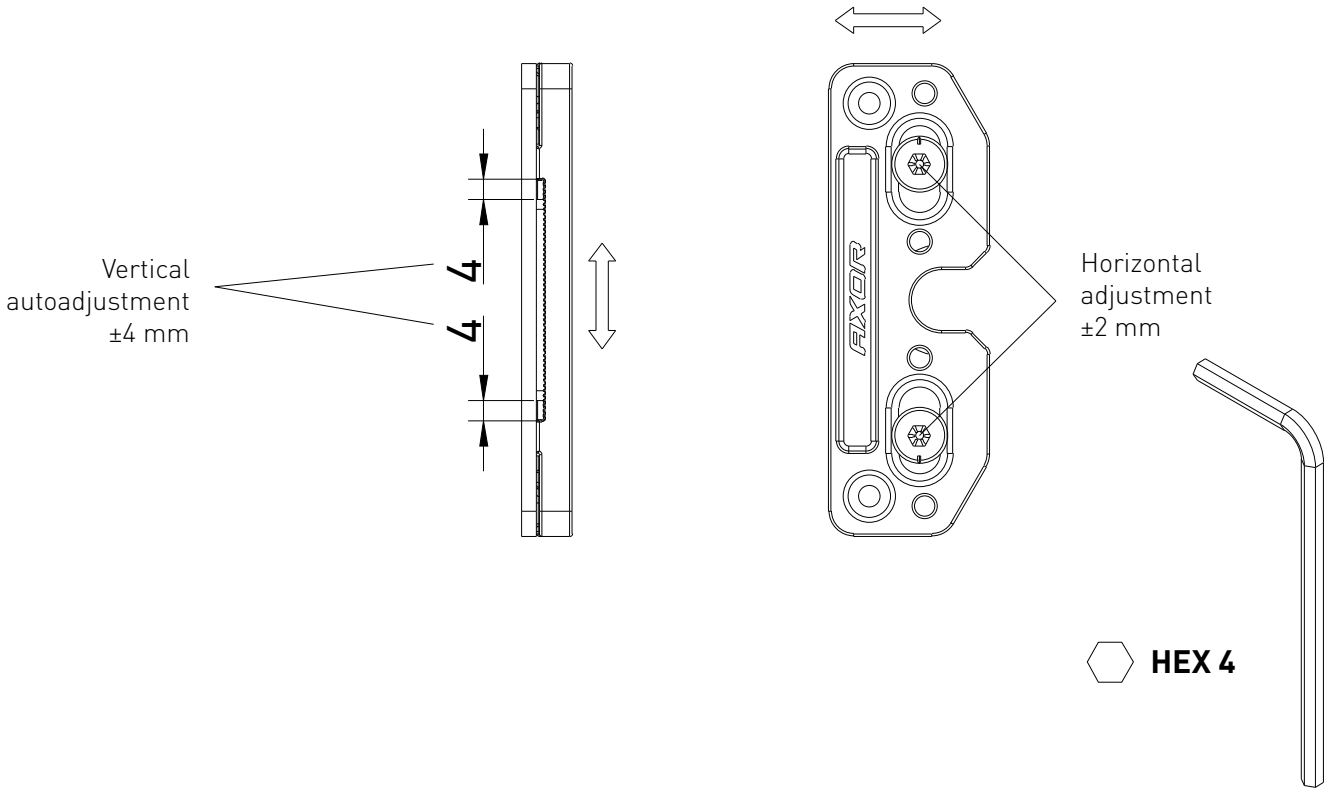

Automatic adjustment

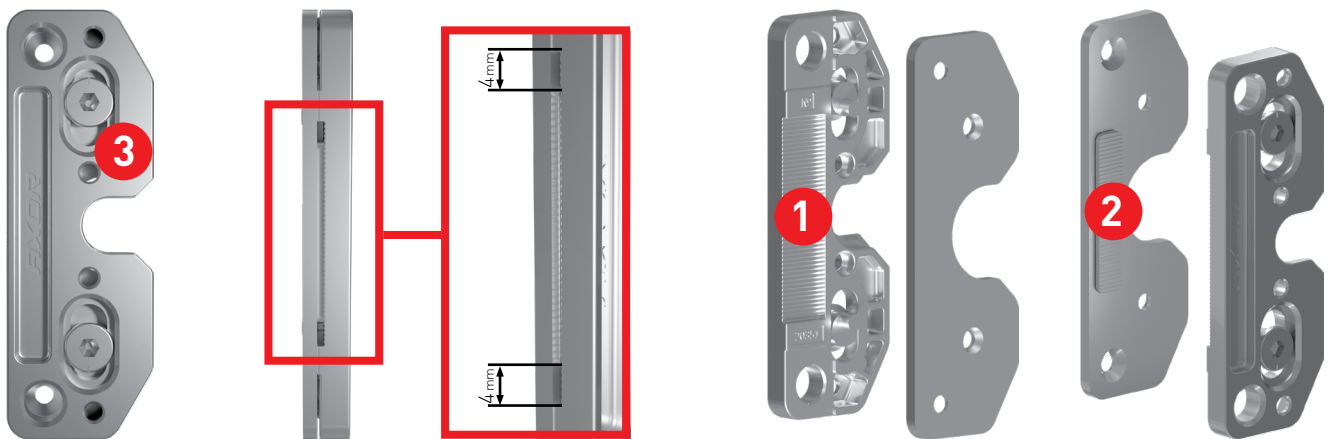

The principle of action: The body of side lock **3** moves vertically along the ribbed surface **2**, as a result of which the element **3** “adjusts” in height to the position of the locking cam on the side lock. Ribbed surface **1** prevents free vertical movement.

Side lock adjustment

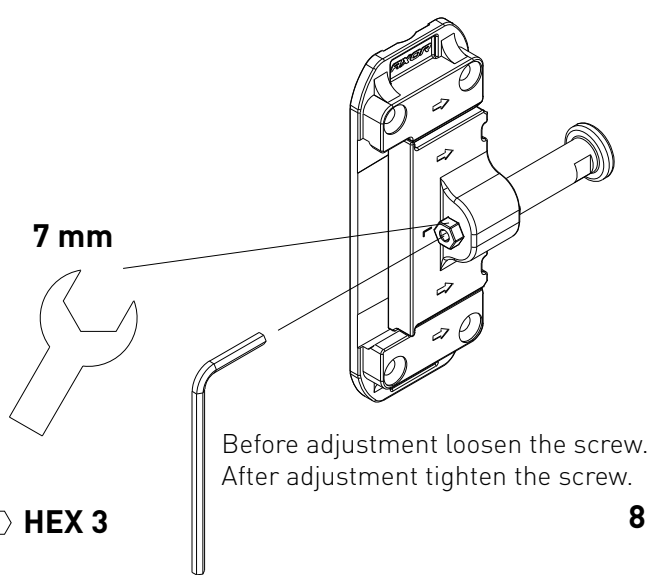
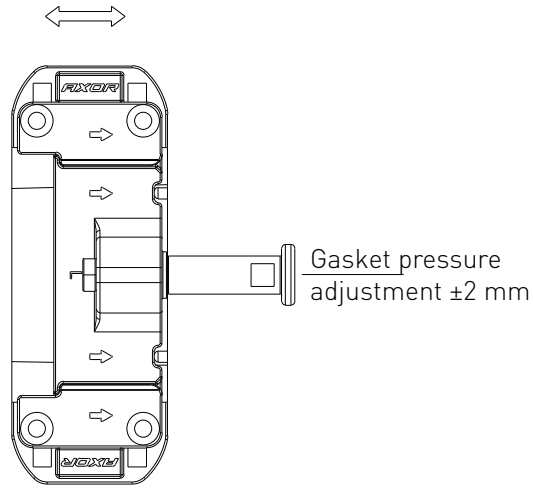

Adjustment can be made by
- allen key 3 mm
- wrench 7 mm

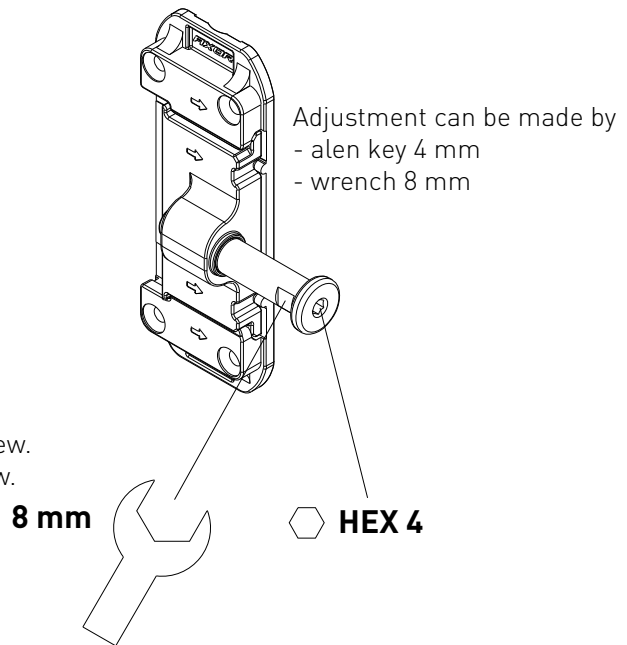

Locking pin adjustment (gasket pressure)

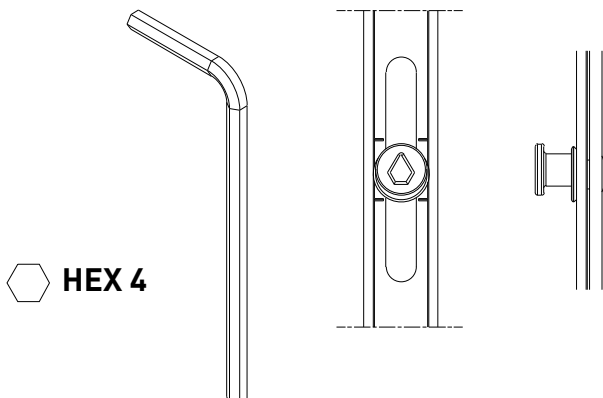

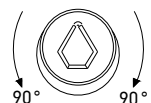
Locking pin	MR	Rotation direction	Adjustment limits
			
			+/-1



AXOR INDUSTRY

 32, Pratsi Avenue,
Dnipro, 49041, Ukraine

 shop@axorindustry.com