

AXORTM



SMART LINE **S+**

window hardware for PVC
and aluminum profiles

CONTENT

<input type="checkbox"/>		Introduction
<input type="checkbox"/>	1	Hinges
<input type="checkbox"/>	2	Gears
<input checked="" type="checkbox"/>	3	Corner transmissions/ Middle locks/ Extensions
<input checked="" type="checkbox"/>	4	Stay arms
<input type="checkbox"/>	5	Additional elements
<input type="checkbox"/>	6	Hardware set combinations
<input checked="" type="checkbox"/>	7	Tools / Instalation/ Adjustments
<input checked="" type="checkbox"/>	8	Profile-dependent elements

Section ▶ Introduction**■ The system SMART LINE S+**

SMART LINE S+ is window hardware's system for turn, tilt & turn, double sash and tilt opening of PVC and aluminum windows, balcony doors and oblique windows.

This system was designed in accordance with market's wishes and offers for each window producer wide decisions' list for comfortable and quality assembly. Besides, end buyers are getting functionality product, saving its exploitation characteristics during whole service life.

SMART LINE S plus allows producing PVC windows with variety levels of burglar resistance. It is achieved by using mushroom locking pins combining with necessity safety locking plates' quantity.

**Application range**

All window furniture in our catalogue is intended exclusively for the internal opening of windows and balcony doors.

The system S+ has been provided in such assemblies as, tilt and turn opening, single turn opening, single tilt opening and double sash opening as well.

Hardware elements

All sets of hardware, which were indicated in this catalogue, must consist only from original elements of AXOR INDUSTRY. Otherwise the producer won't be able to guarantee the work of hardware properly.

Quality

All products of AXOR INDUSTRY corresponds according to technical norms of DSTU Б B.2.6-39:2008, GOST 30777-2012, GOST 538-2001, EN 13126-8 which regulate the main requirements of tilt and turn hardware.

Assembly

So, for accurate an assembly and for further correct work of hardware it is necessary to follow instructions of this catalogue.

Fixing of details:

The handle with screws M5 x 40 mm.

The elements of a sash and the locking plates: self-tapping window chromated screws 4,0 x 25 mm or 3,9 x 26 mm.

The elements of hinges group: galvanized or alternatively chromated screws with flat head and cross-shaped slot, DIN 7982 3,9 x 32 mm or 3,9 x 38 mm.

Preliminary drilling is necessarily for these screws. Perforation instead of drilling is forbidden. Drill diameter for PVC profiles is 0,7, and for steel profiles is 0,8 diameter of a screw. Settings of electric- or pneumatic screwdriver: maximum torque is 2.5 Nm, rotation speed: max 600 - 1000 rpm.

In case of non-compliance of these catalogue's recommendations for assembly and exploitation, the producer AXOR INDUSTRY cannot guarantee properly work of separate elements, as well as, the work of hardware system in whole.

The AXOR INDUSTRY Company reserves the right, in a process of further an improvement and development, to make technical changes of product SMART LINE S+, and also to change packaging norms.

Section ▶ Introduction

■ The locking pins of SMART LINE S+

The system of window hardware SMART LINE S+ was equipped with mushroom pins of sliding.

The adjustment range of locking pins is +/-1 mm.

The diameter of pins is 11 mm.



■ The locking plates



■ Technical features of SMART LINE S+



Applying stay arm for right and left version with increased an operating level till 20 mm of integrated sash's finisher.



Stair-step fixation of finger's angle tilting of bottom frame's hinge prevents spontaneous changing of its position during assembly.



Equipping stay arm with locking pin beginning as early as from size 600-800 mm.



Availability special fixators, at all elements of window hardware, allow fixing preliminary accessories at a sash and prevent its moving from design position during final fixation with selftapping screws.



Simple and reliable junction stay arm to middle lock with special clip makes an assembly more comfortable.

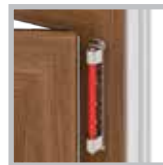

Reliable fixation of top frame's hinge to frame's stay arm thanks to special bush, which was made of Side opening resins, excludes elements' spontaneous disjunctions.



Optimization of production operations' quantity there can be at the moment of junction stay arm to corner transmission – eccentric cut excludes necessity to move a slider at corner transmission, besides reliable fixation of elements takes place with self-tapping screw.



An opportunity to adjust a gasket pressure at bottom sash's hinge in range +/- 0.8 mm.



Bearing pin of top sash's hinge (6x26 mm) was produced of high-tensile-strength steel and integrated into body frame of hinge to give to it additionally strength for heavy sashes.



An opportunity to install "stair-step ventilation" at a mounted already window.

Section ▶ Introduction

■ Plating SMART LINE S+

Analogously all AXOR's output, window hardware SMART LINE S+ has necessity level of anticorrosion resistance thanks to special technology of zinc plating.

It allows window furniture SMART LINE S+ to function surely and save aesthetic – attractive surface appearance during while service life upon condition of abidance exploitation's rules and recommendations for servicing.

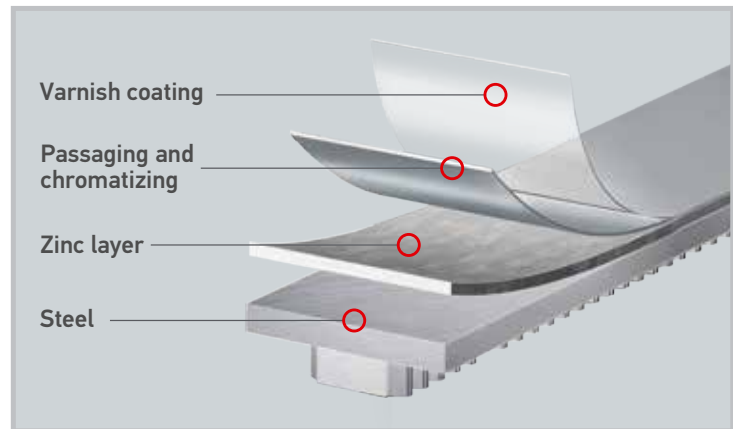

The causes to appear the corrosion at hardware's surface.

- 1) The prolonged exposure of high wetness (more than 70%).
- 2) The polluted air with gas, comprising a connection of various acids, and an exposure of salt-mist.
- 3) The mechanical damages of surface during an assembly or maintenance, which disrupt wholeness of the plating.
- 4) Some cleaning agents include alkali, acid and so on.
- 5) Under the influence of different temperature there can appear the formation of condensate at the surface of hardware.
- 6) The pollution with some building materials, in particular by cement or gypsum plaster.

Some instructions to keep the quality of surface plating

- 1) Avoid hits of building materials at the hardware surface, for example plaster, cement, different building solutes and building dust.
- 2) Avoid any exposure of aggressive acidic steam and salt-mists at the hardware surface.
- 3) Do not use any rubber gasket, which is able to soaks up and to hold some moisture.
- 4) The cleaning should be made with pH-neutral solute, before diluted.
- 5) Do not permit any mechanical damages of the hardware's surface by building, assembly and detergent instruments.







Storage conditions

This applies to storage and transport, as well as for unloading and loading procedures. Where appropriate, plastic protective sheets or similar are to be used during outdoor transport when raining (i.e. on-site transport). Storage may only be carried out in suitable, closed rooms and not outdoors. Condensation is to be absolutely avoided during the entire transport and storage duration.

- 1) Always keep the hardware boxes closed, and always cover up hardware boxes which were opened and do not put boxes directly on the floor.
- 2) Transport the hardware always with suitable devices (if possible on pallets with stretch film).
- 3) The components may not get wet. The packaging must remain dry (it is recommended: Warehouse temperature – 15-25 °C; Relative humidity – less then 50%).
- 4) If box becomes wet please immediately unpack the components from the wet bundles, dry the components and check for signs of corrosion. In any case repack the usable components when dry with new packing material.

Section ▶ Introduction

■ Basic notations

	Maximum sash weight, kg		Drill-bit (diameter)
	Screws (quantity/size)		Mushroom locking pin
	Packaging quantity (pcs)		Locking plate for double-sash window



Tilt and turn sash



Tilt and turn double sash



Turn-only sash



Tilt-only sash



Tilt and turn sash for oblique windows

■ Representation of the information

All article numbers in this catalogue were afforded an alphanumeric form. The decipher of all article numbers you can find at the pages 9-10.

Thus, all sizes which were shown in that catalogue are nominal and contain general tolerances.

All sizes were conferred in mm.

The information about restriction of sashes' sizes should be taken from diagrams of this catalogue or a user's guide.

Section ▶ Introduction

■ The single sash constructions

Sash rebate gap (A):	min. 12 mm
Sash overlap (C):	18 – 22 mm
Sash groove position (B):	9 mm

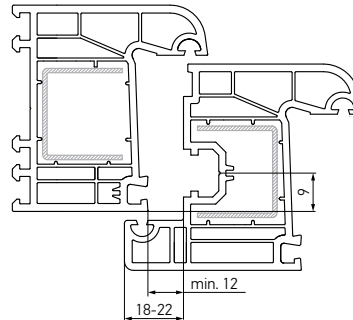

Sash rebate gap (A):	min. 12 mm
Sash overlap (C):	18 – 22 mm
Sash groove position (B):	13 mm

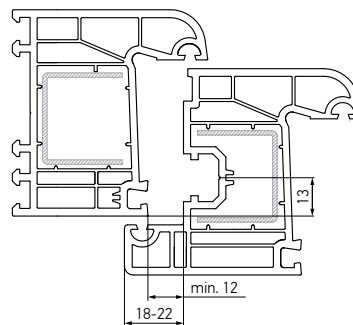

■ The double sash constructions with opposite hardware groove

Sash rebate gap (A):	min. 12 mm
Sash overlap (C):	18 – 22 mm
Sash groove position (B):	9 mm

The handling of a passive sash with double sash's gears S1002-XX-N03

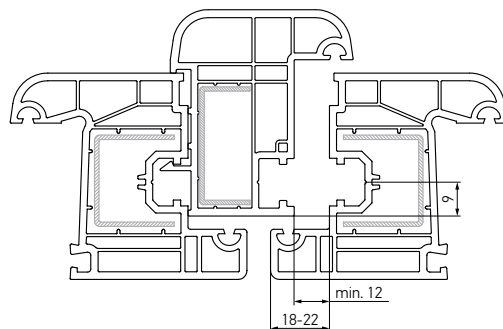

Sash rebate gap (A):	min. 12 mm
Sash overlap (C):	18 – 22 mm
Sash groove position (B):	13 mm

The handling of a passive sash with double sash's gears S1002-XX-N03

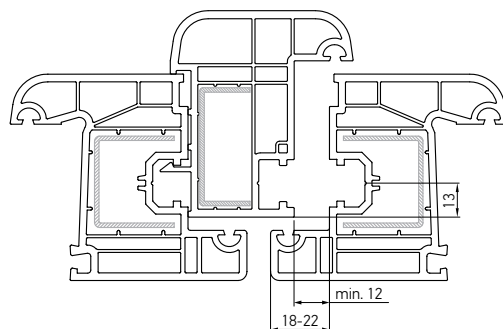

The information about profile-dependent elements you find at the profile list



Section ▶ Introduction

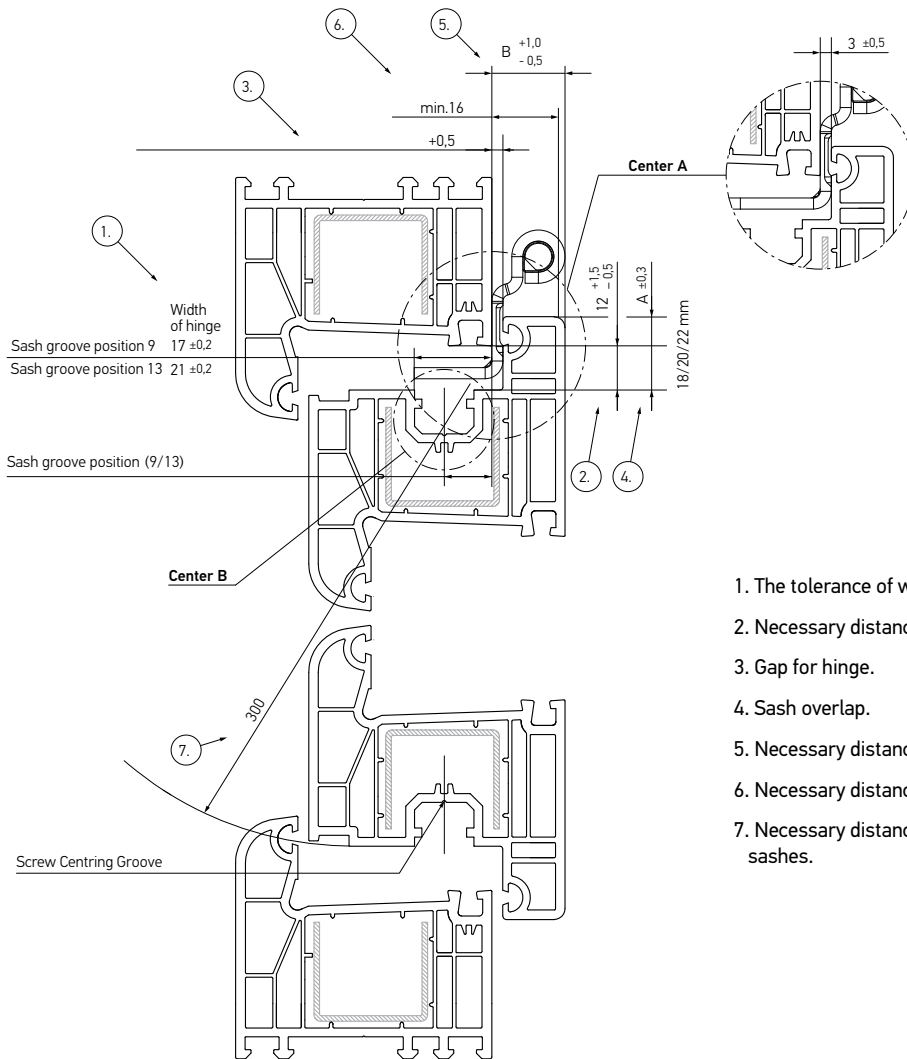

1. The tolerance of width for top sash's hinge.
2. Necessary distance for moving the hardware.
3. Gap for hinge.
4. Sash overlap.
5. Necessary distance for the clamping of gasket adjustment.
6. Necessary distance for inserting a hinge into sash overlap.
7. Necessary distance for operation of small turn and tilt-turn sashes.

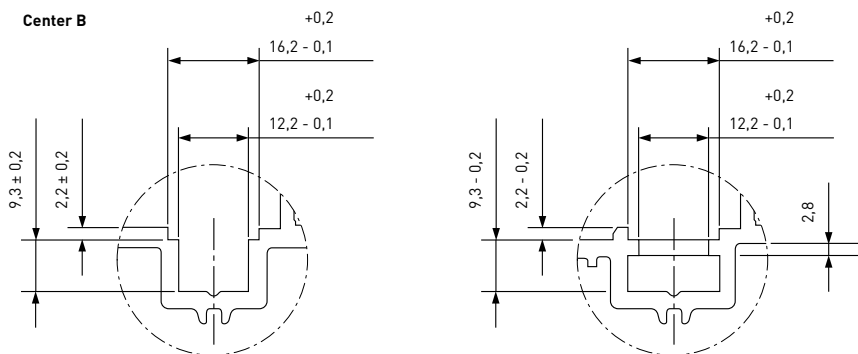

Dimensions for plastic profile according RAL as of February 1998.

Gütegemeinschaft Schlösser und Beschläge e.V., Offerstr.
12, 42551 Velbert

Section ▶ Introduction

■ Aluminum profile, sash groove position 9 mm

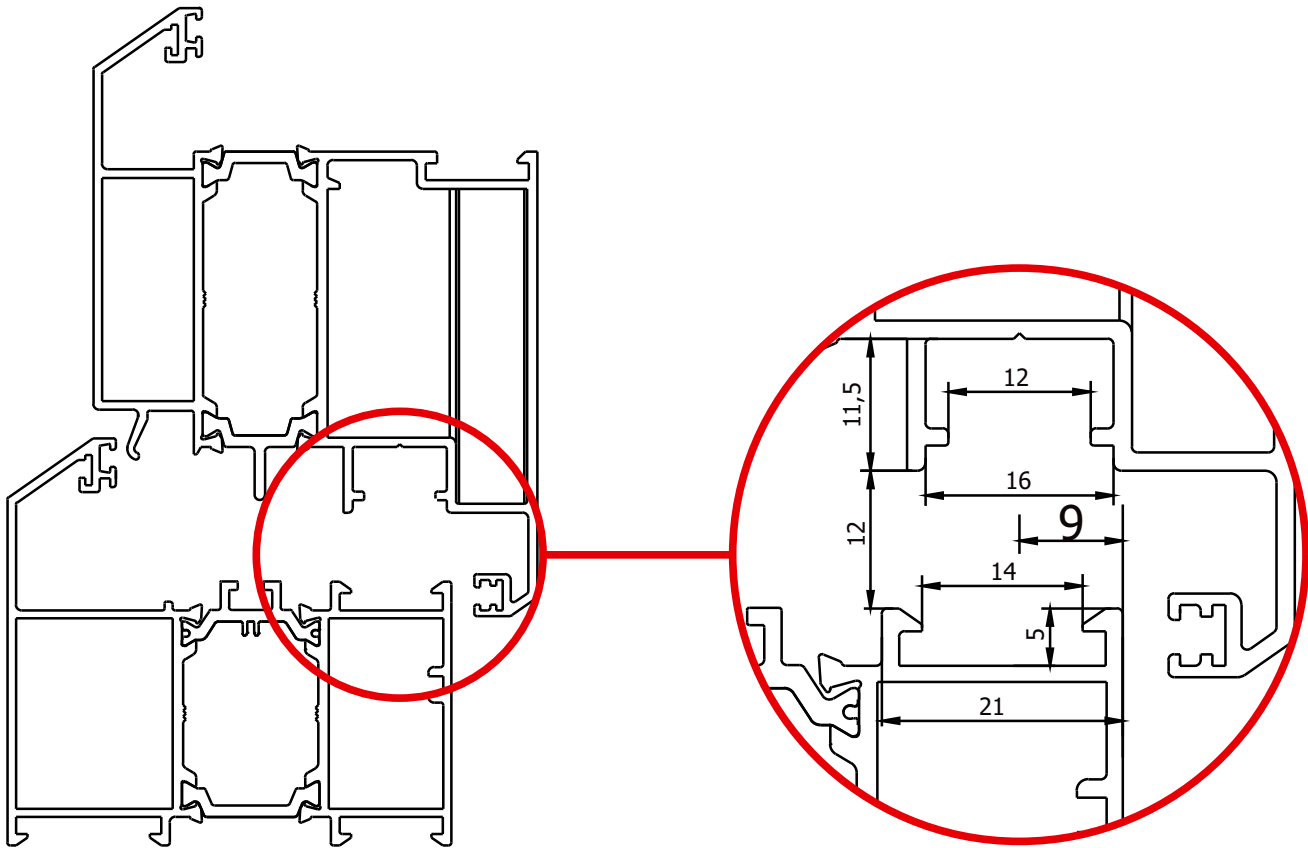

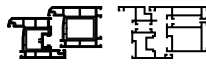

Section ▶ Introduction

■ Article structure

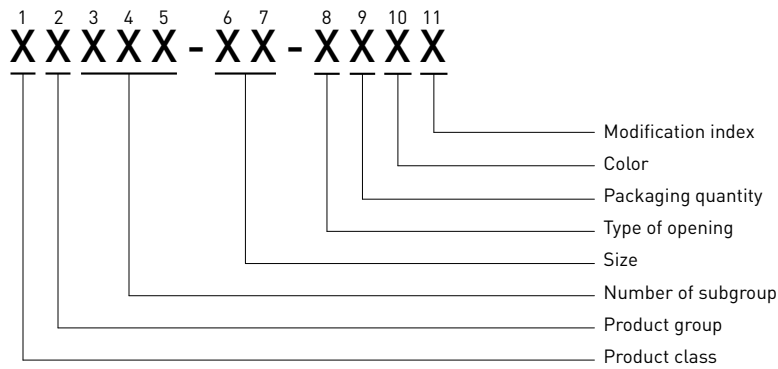

**1. Product class
(1st sign)**

XXXXX-XX-XXXX

- “S” – Smart Line S+
- “K” – Komfort Line K-3
- “A” – element refers to both classes

**2. Product group
(2nd sign)**

X**X**XXX-XX-XXXX

- “0” – alternative value
- “1” – gear variable
- “2” – corner transmissions
- “3” – stay arm
- “4” – extensions
- “5” – hinges
- “6” – standart locking plates, tilt locking plates
- “7” – locking plates and the other accessories
- “8” – alternative value
- “9” – alternative value

**3-5. Subgroup number
(3rd, 4th and 5th sign)**

Xx**XXX**-XX-XXXX

Additional information about product’s subgroup.
 Example: group “gears”, subgroup “double sash lever espagnolette variable”.

**6-7. Size
(6th and 7th sign)**

XXXXX-**XX**-XXXX

Important dimensions of the product such as the length of the axis, etc.

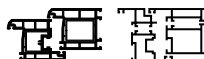

Section ▶ Introduction

**8. Type of opening
(8th sign)**

XXXXX-XX-**X**XXX

- "N" – universal
- "R" – right
- "L" – left

**9. Packaging quantity
(9th sign)**

XXXXX-XX-**X**XXX

- | | | |
|-------------------------|----------------|----------------------------|
| "O" – standard quantity | "J" – 40 pcs. | "T" – 1000 pcs. |
| "B" – 1 pcs. | "K" – 50 pcs. | "V" – 1500 pcs. |
| "C" – 2 pcs. | "L" – 100 pcs. | "W" – 3000 pcs. |
| "D" – 5 pcs. | "M" – 125 pcs. | "Y" – 5000 pcs. |
| "E" – 10 pcs. | "N" – 200 pcs. | "Z" – nonstandard quantity |
| "F" – 20 pcs. | "P" – 250 pcs. | |
| "G" – 25 pcs. | "R" – 400 pcs. | |
| "H" – 30 pcs. | "S" – 500 pcs. | |

**10. Color and plating
(10th sign)**

XXXXX-XX-**XX**X

- | | | |
|-------------|---------------|--------------------|
| 0 – plating | 4 – champagne | 8 – steel surface |
| 1 – white | 5 – gold | 9 – special colors |
| 2 – brown | 6 – bronze | |
| 3 – silver | 7 – black | |

Double encoding can be used for several tones of the same color.

Example: 1 – white color RAL 9016

1B – white color RAL 9010

**11. Modification index (A, B, C)
(11th sign)**

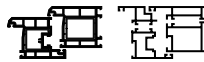

Section ▶ Introduction

■ Tilt and turn

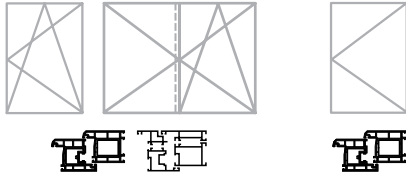

Allowable sash dimensions
 Allowable sash weight for this range 100 kg
 1mm/m² glass thickness= 2.5kg

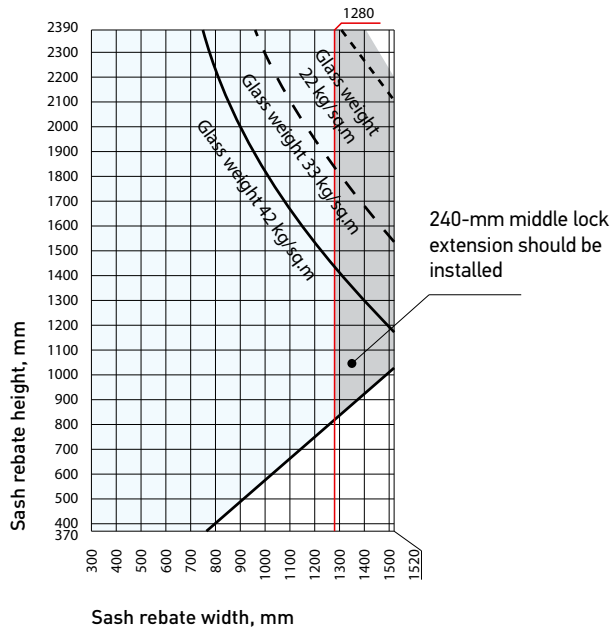

Valid sash's size
 Permissible sash's weight for this range is 130 kg max.
 1 mm / m² glass thickness = 2.5

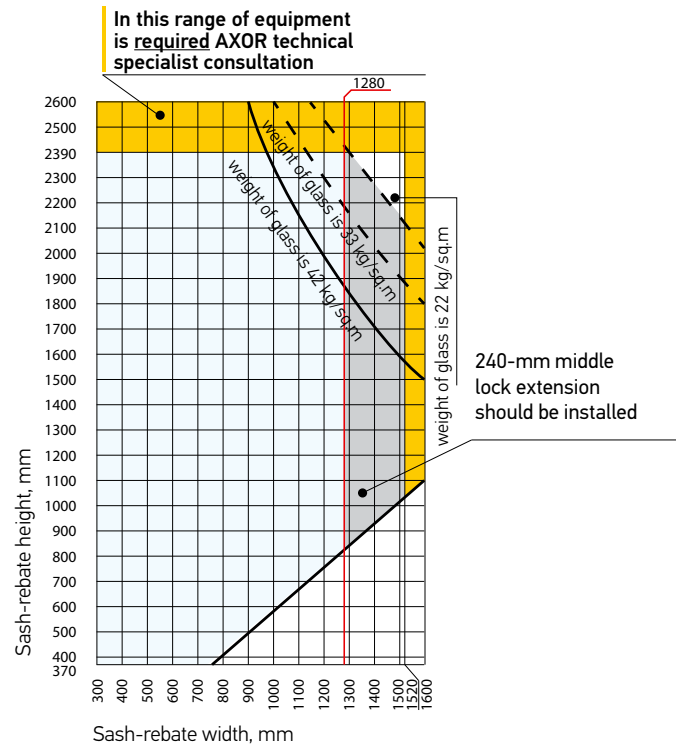

■ Tilt sash



Sash dimensions limits
 Maximum sash weight is 50 kg

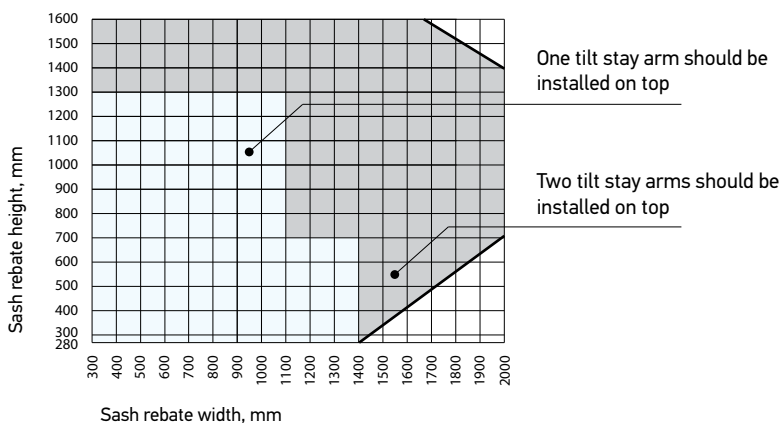

Section ▶ Introduction

■ Safety conventional symbols

Conventional symbol	Meaning
	<p>Danger of injury through trapping of body parts</p> <ul style="list-style-type: none"> ■ Never reach into the opening between the sash and the outer frame when closing windows/doors.
	<p>Risk of injury from falling through open windows</p> <ul style="list-style-type: none"> ■ Always use stable step ladders. ■ Protect yourself against falling out of windows. ■ Do not steady yourself or hold on to the opened sash.
	<p>Risk of injury or damage from pressing the sash against the reveal</p> <ul style="list-style-type: none"> ■ Do not press the sash against the window reveal.
	<p>Risk of injury from trapping parts of the body between the sash and the frame</p> <ul style="list-style-type: none"> ■ Do not insert obstructions into the opening between sash and frame.
	<p>Risk of injury and material damage from overloading the sash</p> <ul style="list-style-type: none"> ■ Do not overload the sash.
	<p>Risk of injury from the effect of wind</p> <ul style="list-style-type: none"> ■ Prevent wind from acting on the open sash. ■ During wind/drafts, close and lock windows

■ **Certificate ISO 9001:2015**

Сертификат

Стандарт **ISO 9001:2015**

Рег. № сертификата **01 100 1519050**

TÜV Rheinland Cert GmbH подтверждает:

Держатель сертификата:

**Общество с Ограниченной
Ответственностью
«АКСОР ИНДАСТРИ»**
49041, г. Днепро,
Пр. Труда 32,
Украина



Сфера действия:

Производство и реализация устройств поворотных, откидных и поворотно - откидных для оконных и балконных дверных блоков.

По итогам проведенного аудита соответствие требованиям стандарта ISO 9001:2015 подтверждено.

Дата очередных аудитов до 30 Января.

Срок действия:

Настоящий сертификат действителен от **31.03.2018** до **30.03.2021**.
Первый сертификат выдан в 2015 г.

30.03.2018



TÜV Rheinland Cert GmbH
Am Grauen Stein · 51105 Köln

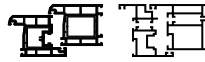

Section ▶ Introduction

■ Certificate DSTU Б В. 2.6-29:2008

 ПРИЗНАЧЕНИЙ МІНІСТЕРСТВОМ ЕКОНОМІЧНОГО РОЗВИТКУ І ТОРГІВЛІ УКРАЇНИ ОРГАН З ОЦІНКИ ВІДПОВІДНОСТІ ОС «ПРОМСТАНДАРТ» СЕРТИФІКАТ ВІДПОВІДНОСТІ СЕРТИФІКАТ СООТВЕТСТВИЯ CERTIFICATE OF CONFORMITY СИСТЕМА СЕРТИФІКАЦІЇ ПРОДУКЦІЇ «ОС «ПРОМСТАНДАРТ»		Серія ВВ
Зареєстровано в Реєстрі органу з оцінки відповідності за № <u>UA.TR.061.002705-18</u> Зарегистрирован в Реестре органа по оценке соответствия Registered at the Record of conformity assessment body under		
Термін дії з <u>28 листопада 2018р. до 27 листопада 2020р.</u> Срок действия с Term of validity is from		8302 <small>www.ukr.zed.tki.zed</small>
Продукція (тип) Продукция (тип) Production (type)	Пристрої поворотні, відкидні і поворотно-відкидні для віконних та балконних блоків ТМ AXOR системи «SMART LINE S PLUS»	25.72.14 <small>www.ukr.zed.tki.zed</small>
Відповідає вимогам Соответствует требованиям Comply with the requirements	ДСТУ Б В. 2.6-39:2008, п. 5.3 - 5.5, п.п. 5.2.3, 5.2.4, 5.6.1	
Виробник (и) продукції Изготовитель (и) продукции Producer (s)	ТОВ «АКСОР ІНДАСТРІ», код ЄДРПОУ 37806217, юридична адреса: Україна, 49083, м. Дніпро, вул. Собінова, 1; адреса виробництва: Україна, 49041, м. Дніпро, пр. Праці, 32	
Сертифікат видано Сертификат выдан Certificate is issued on	ТОВ «АКСОР ІНДАСТРІ», код ЄДРПОУ 37806217, юридична адреса: Україна, 49083, м. Дніпро, вул. Собінова, 1 Пристрої поворотні, відкидні і поворотно-відкидні для віконних та балконних блоків ТМ AXOR системи «SMART LINE S PLUS», що виготовляються серійно в період з 28.11.2018р. по 27.11.2020р. з урахуванням гарантійного терміну зберігання. Технічний нагляд один раз на рік. Висновок державної санітарно-епідеміологічної експертизи Міністерства охорони здоров'я України від 24.02.2015р. №05.03.02-04/7005. Сертифікат на відповідність ISO 9001:2015 від 31.03.2018р за №011001519050, виданий TÜV Rheinland Cert GmbH, Німеччина	
Додаткова інформація Дополнительная информация Additional information		
Сертифікат видано органом з оцінки відповідності Сертификат выдан органом по оценке соответствия Certificate is issued by the conformity assessment body	Орган з оцінки відповідності ТОВ «Орган з сертифікації «ПромСтандарт», реєстраційний номер призначення №UA.TR.061, 49000, м. Дніпро, вул. Староколяцька, 56, к. 2, 3, т. (056) 742-82-39	
На підставі На основании On the grounds of	протокол випробувань №522с-ВЛ від 28.11.2018р., виданого ВЛ ТОВ «Будіндустрія, ЛТД», Україна, 69035, м. Запоріжжя, проспект Соборний, будинок 170 Г, квартира 32, атестат акредитації № 2Н790 терміном дії до 29.09.2022р., акт обстеження виробництва №061/2459С від 27.11.2018р. ТОВ «ОС «ПромСтандарт»	
Керівник органу з оцінки відповідності Руководитель органа по оценке соответствия Director of the conformity assessment body	М.П. 728808 061	С.В. Дубровський ініціали, прізвище
Чисність сертифікату можна перевірити в Реєстрі Систем органу на сайті promstandart.com.ua або за тел.(056) 742-82-39		№008209

Section ▶ Introduction

■ Certificate ift Rosenheim QM 328

Zertifikat / Certificate

Zertifikatsnr. / Certificate No.: 228-9003481-1-8

Dreh- und Drehkippsbeschläge für Fenster und Fenstertüren

Turn and tilt-turn hardware for windows and casement doors

Produkt product	AXOR K3, AXOR S PLUS, AXOR Elite Plus
max. Flügelgewicht max. casement weight	130 kg
Einsatzbereich field of application	Systeme mit entsprechender Beschlagaufnahme Systems with suitable hardware groove
Hersteller manufacturer	AXOR Industry 1, Sobinova Str., UA 49083 Dnepropetrovsk
Produktionsstandort production site	AXOR Industry 1, Sobinova Str., UA 49083 Dnepropetrovsk

Mit diesem Zertifikat wird bescheinigt, dass das benannte Bauprodukt den Anforderungen des zugrundeliegenden ift-Zertifizierungsprogramms in der aktuellen Fassung entspricht.

Erstellung von Produktfamilien des aufgeführten Bauproduktes und Erstprüfung durch eine akkreditierte Prüfstelle nach EN 13126-8:2017 unter Berücksichtigung der Anwendungsdiagramme Einführung und Aufrechterhaltung einer werkseigenen Produktionskontrolle durch den Hersteller Erstinspektion des Werkes und der werkseigenen Produktionskontrolle durch ift-Q-Zert kontinuierliche Fremdüberwachung des Werkes und der werkseigenen Produktionskontrolle durch ift-Q-Zert

Dieses Zertifikat wurde erstmals am 21.05.2014 ausgestellt und gilt 5 Jahre, wenn sich zwischenzeitlich die Festlegungen in der oben angeführten technischen Spezifikation oder die Herstellbedingungen im Werk oder in der werkseigenen Produktionskontrolle selbst nicht wesentlich verändert haben.

Das Zertifikat darf nur unverändert vervielfältigt werden. Alle Änderungen der Voraussetzungen für die Zertifizierung sind dem ift-Q-Zert mit den erforderlichen Nachweisen unverzüglich schriftlich anzuzeigen.

Das Unternehmen ist berechtigt, das benannte Bauprodukt gemäß der ift-Zeichensatzung mit dem „ift-zertifiziert“-Zeichen zu kennzeichnen.

Dieses Zertifikat enthält 2 Anlage/n.

This certificate attests that the building product mentioned fulfils the requirements of the underlying ift-certification scheme in its current version.

compilation of product families of the building product listed and initial type-testing by an accredited testing body as per EN 13126:8:2017 based on the application diagrams implementation and maintenance of a factory production control by the manufacturer initial inspection of the production site and the factory production control by ift-Q-Zert continuous third-party control of the production site and the factory production control by ift-Q-Zert

This certificate was first issued on 21.05.2014 and will remain valid for 5 years, as long as neither the conditions laid down in the technical specification listed above nor the manufacturing conditions in the production site nor the factory production control itself are modified significantly.

The reproduction of the certificate without any change from the original is permitted. Any changes to the prerequisites applicable to certification shall be immediately communicated in writing to ift-Q-Zert accompanied by the necessary evidence.

The company is authorized to affix the "ift-certified"-mark to the building product mentioned according to the ift-rules for use of the "ift-certified"-mark.

This certificate contains 2 annexes.

Grundlage(n) / Basis:

ift-Zertifizierungsprogramm für Beschläge
ift-certification scheme for hardware (QM 328)
Ausgabe/ Issue: 2018

EN 1191
EN 12400
Klasse 2
class 2

Dauerfunktion
resistance to repeated opening and closing

EN ISO 9227
EN 1670
Klasse 5
class 5

Korrosionsschutz
corrosion protection

ift Rosenheim
04.10.2019

Gültig bis / Valid until: 20.05.2024

We-Zert-5172-de / nr 07.mta

Christian Kehrer
Leiter der ift-Zertifizierungs- und Überwachungsstelle
Head of ift Certification and Surveillance Body

Prof. Ulrich Sieberath
Institutsleiter
Director of Institute

228 9003481

www.ift-rosenheim.de

ift Rosenheim GmbH
Theodor-Greif-Str. 7-9
D-63006 Rosenheim

Kontakt
Tel: +49 8031 261-0
Fax: +49 8031 261-290
www.ift-rosenheim.de

Prüfung und Kalibrierung – EN ISO/IEC 17025
Inspektion – EN ISO/IEC 17020
Zertifizierung Produkte – EN ISO/IEC 17065
Zertifizierung Managementsysteme – EN ISO/IEC 17021

Notified Body 0137
DAKKS
Dachverband der Akkreditierten Körperschaften
D-53111 Bielefeld

[1]

SMART LINE S+

Hinges

Section 1 ▶ Hinges

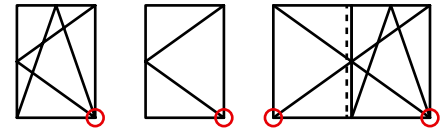

■ **Corner bearing 3x3**

■ **Covers of corner bearing**

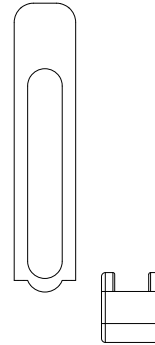
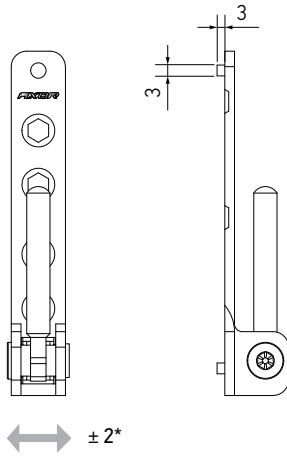

- maximum tilting of pin inclination - 180 deg;
- for appropriate sash hinge look at p. 19-23;
- for decorative covers in other colors look at p. 28.

* horizontal adjustment, mm.

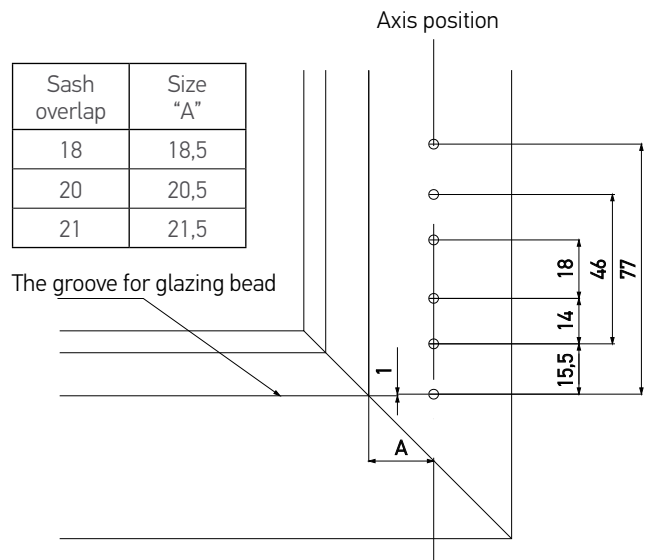

Description	A	C	B	kg			Part No.
Corner bearing 3x3	12	20	—	100	4/3,9x40	250	A5002-00-N03
Bottom cover of corner bearing	—	—	—	—	—	500	A7007-10-N**
Top cover of corner bearing	—	—	—	—	—	500	A7008-10-N**
Description	A	C	B	kg			Part No.
Drilling jig for frame hinges	12	20	—	—	Ø3	10	A7002-00-N09
Drilling jig for frame hinges	12	21	—	—	Ø3	10	A7002-20-N09

A - Sash rebate gap / C - Sash overlap / B - Sash groove position
 ** - for decorative covers in other colors look at p. 28



Section 1 ▶ Hinges

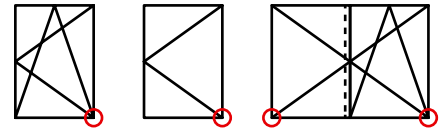

■ Corner bearing 6x22

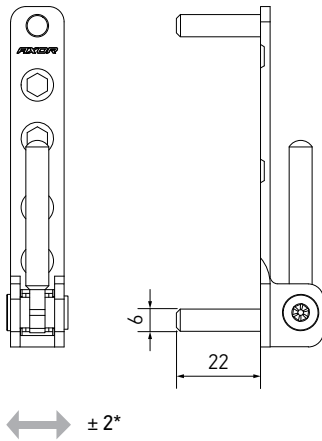

- maximum tilting of pin inclination - 180 deg;
- for appropriate sash hinge look at p. 20-23;
- for decorative covers in other colors look at p. 28.

* horizontal adjustment, mm.

■ Covers of corner bearing

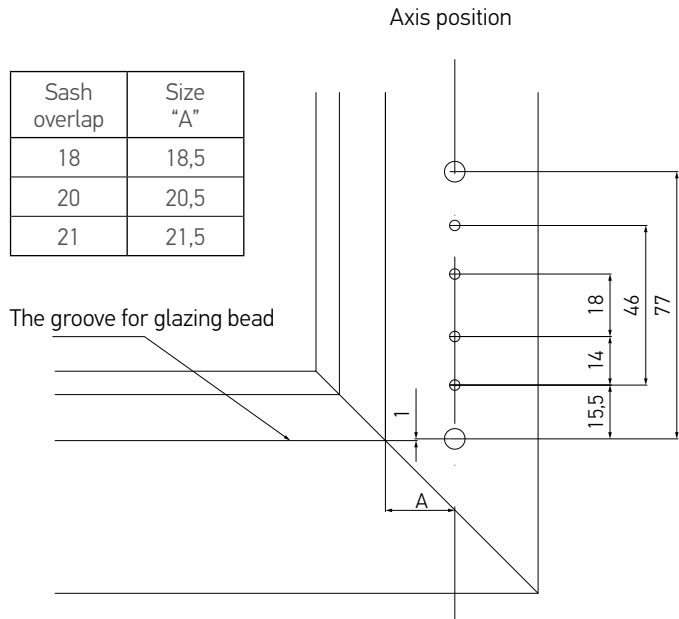
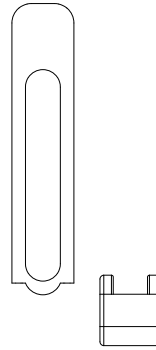

Description	A	C	B	kg			Part No.
Corner bearing 6x22	12	20	—	130	4/3,9x40	250	A5004-00-N03
Bottom cover of corner bearing	—	—	—	—	—	500	A7007-10-N**
Top cover of corner bearing	—	—	—	—	—	500	A7008-10-N**
Description	A	C	B	kg			Part No.
Drilling jig for frame hinges	12	20	—	—	Ø3/6	10	A7002-10-N09
Drilling jig for frame hinges	12	21	—	—	Ø3/6	10	A7002-30-N09

A - Sash rebate gap / C - Sash overlap / B - Sash groove position

** - for decorative covers in other colors look at p. 28

Section 1 ▶ Hinges

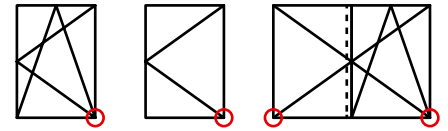

■ **Drill-in corner hinge 3x5**

■ **Cover of the drill-in corner hinge**

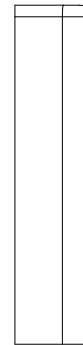
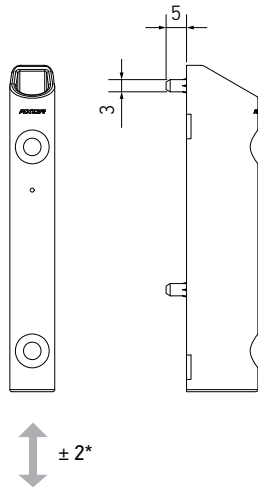

- used for 18-22 mm sash overlap;
- for appropriate sash hinge look at p. 17-18;
- for decorative covers in other colors look at p. 28.

* vertical adjustment, mm.

Axis of sash groove position

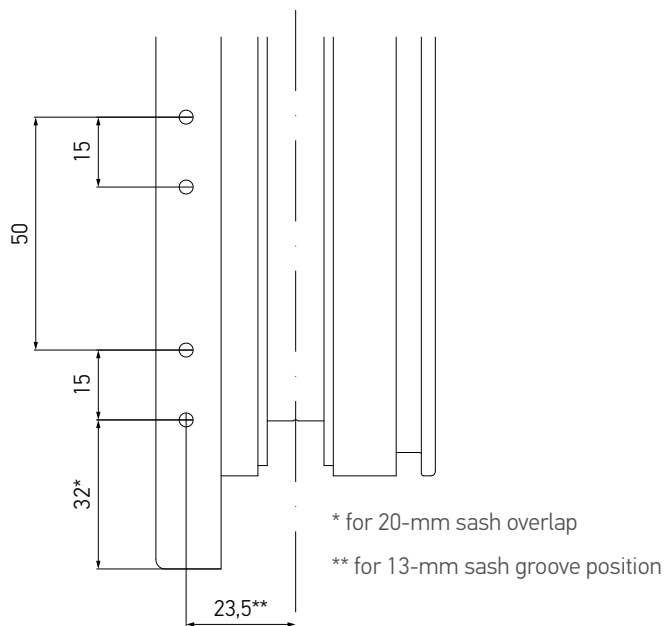

Description	A	C	B	kg			Part No.
Drill-in corner hinge 3x5	—	—	—	100	2 / 4x40	250	A5003-00-N03
Cover of the drill-in corner hinge	—	—	—	—	—	500	A7006-10-N**
Description	A	C	B	kg			Part No.
Drilling jig for sash hinges	12	20	—	—	Ø3	10	A7003-00-N09
Drilling jig for sash hinges	12	21	—	—	Ø3	10	A7003-20-N09

A - Sash rebate gap / C - Sash overlap / B - Sash groove position

** - for decorative covers in other colors look at p. 28



Section 1 ▶ Hinges

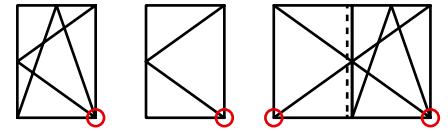

■ Drill-in corner hinge 6x12

■ Cover of the drill-in corner hinge

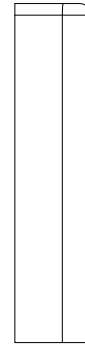
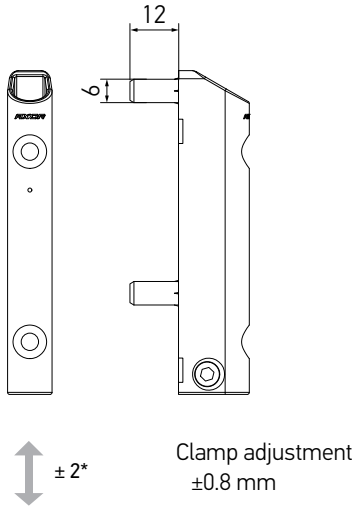

- used for 18-22 mm sash overlap;
- for appropriate sash hinge look at p. 17-18;
- for decorative covers in other colors look at p. 28.

* vertical adjustment, mm.

Axis of sash groove position

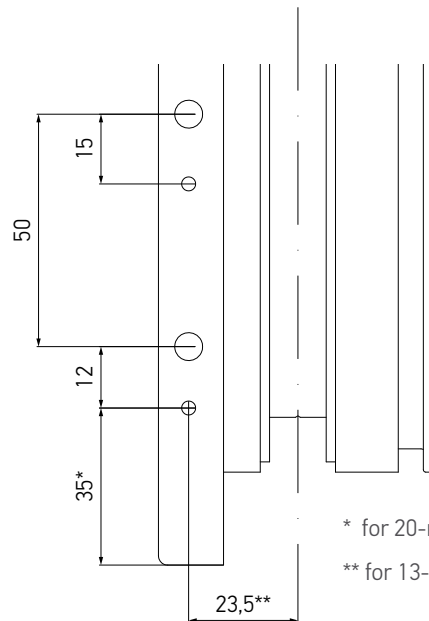

* for 20-mm sash overlap

** for 13-mm sash groove position

Description	A	C	B	kg			Part No.
Drill-in corner hinge 6x12	—	—	—	100	2 / 4x40	250	A5007-00-N03
Cover of the drill-in corner hinge	—	—	—	—	—	500	A7006-10-N**
Description	A	C	B	kg			Part No.
Drilling jig for sash hinges	12	20	—	—	Ø3/6	10	A7003-10-N09
Drilling jig for sash hinges	12	21	—	—	Ø3/6	10	A7003-30-N09

A - Sash rebate gap / C - Sash overlap / B - Sash groove position

** - for decorative covers in other colors look at p. 28



Section 1 ▶ Hinges

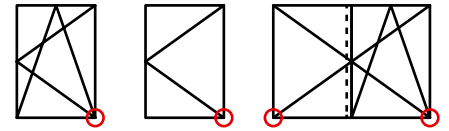

■ Drill-in corner hinge 6x16x26

■ Cover of drill-in corner hinge

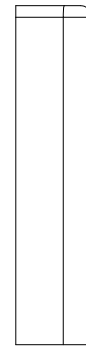
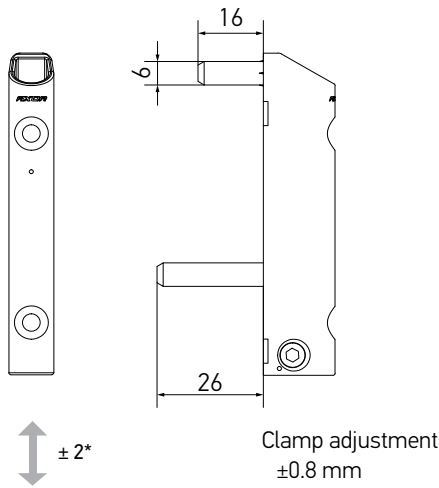

- used for 18-22 mm sash overlap;
- for appropriate sash hinge look at p. 17-18;
- for decorative covers in other colors look at p. 28.

* vertical adjustment, mm.

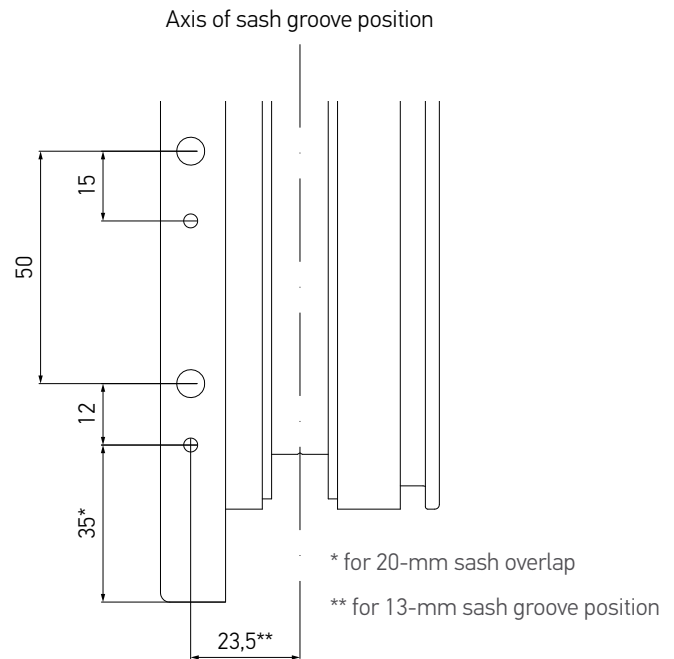

Description	A	C	B	kg			Part No.
Drill-in corner hinge 6x16x26	—	—	—	130	2 / 4x40	250	A5006-00-N03
Cover of the drill-in corner hinge	—	—	—	—	—	500	A7006-10-N**
Description	A	C	B	kg			Part No.
Drilling jig for sash hinges	12	20	—	—	Ø3/6	10	A7003-10-N09
Drilling jig for sash hinges	12	21	—	—	Ø3/6	10	A7003-30-N09

A - Sash rebate gap / C - Sash overlap / B - Sash groove position
 ** - for decorative covers in other colors look at p. 28



Section 1 ▶ Hinges

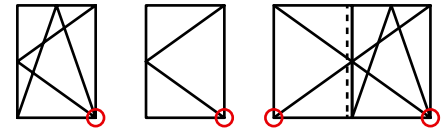

■ Drill-in corner hinge 6x16x26

■ Cover of drill-in corner hinge

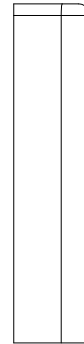
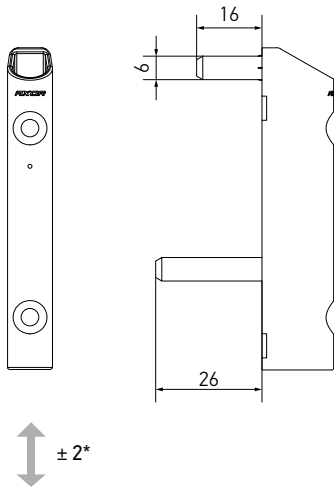

- used for 18-22 mm sash overlap;
- for appropriate sash hinge look at p. 17-18;
- for decorative covers in other colors look at p. 28.

* vertical adjustment, mm.

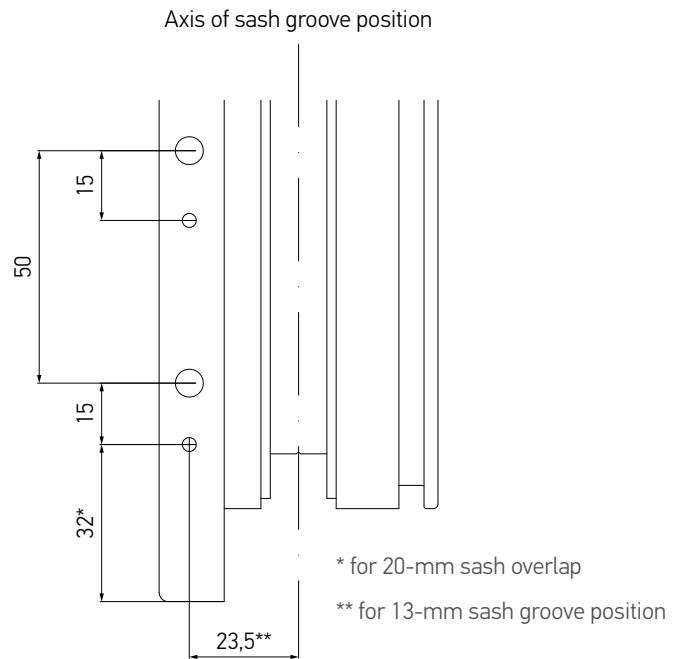

Description	Side opening	A	C	B	kg			Part No.
Drill-in corner hinge 6x16x26	L/R	—	—	—	130	2 / 4x40	250	A5008-00-N03
Cover of the drill-in corner hinge	L/R	—	—	—	—	—	500	A7006-10-N**
Description		A	C	B	kg			Part No.
Drilling jig for sash hinges		12	20	—	—	Ø3/6	10	A7003-10-N09
Drilling jig for sash hinges		12	21	—	—	Ø3/6	10	A7003-30-N09

A - Sash rebate gap / C - Sash overlap / B - Sash groove position
 ** - for decorative covers in other colors look at p. 28

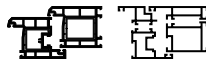

Section 1 ▶ Hinges

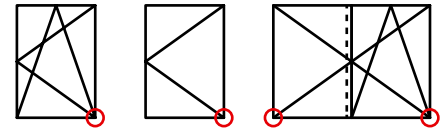

■ **Rebate corner hinge**

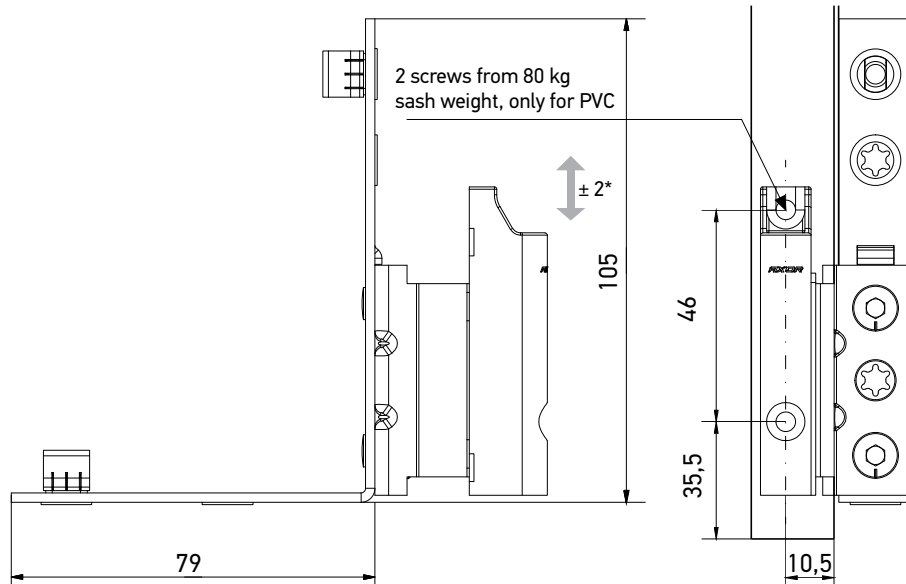

- used for 18/20 mm sash overlap;
- for appropriate sash hinge look at p. 17-18;
- for decorative covers in other colors look at p. 28.

* vertical adjustment, mm

■ **Cover of rebate corner hinge**

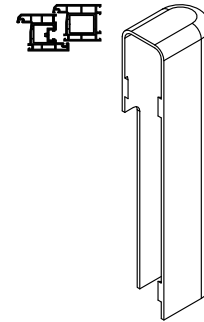

■ **Cover of rebate corner hinge**

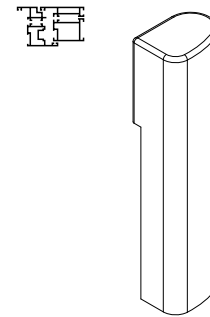

Description	Side opening	A	C	B	kg	←	↕	Part No.
Rebate corner hinge 18/9 left	L	12	18	9	100	7	50	A5010-09-L03
Rebate corner hinge 18/9 right	R	12	18	9	100	7	50	A5010-09-R03
Rebate corner hinge 20/9 left	L	12	20	9	130	7	50	A5009-09-L03
Rebate corner hinge 20/9 right	R	12	20	9	130	7	50	A5009-09-R03
Rebate corner hinge 20/13 left	L	12	20	13	130	7	50	A5009-13-L03
Rebate corner hinge 20/13 right	R	12	20	13	130	7	50	A5009-13-R03
Cover of rebate corner hinge, left	L	—	—	—	—	—	500	A7009-10-L**
Cover of rebate corner hinge, right	R	—	—	—	—	—	500	A7009-10-R**
Cover of rebate corner hinge, left	L	—	—	—	—	—	500	A7085-00-L**
Cover of rebate corner hinge, right	R	—	—	—	—	—	500	A7085-00-R**

A - Sash rebate gap / C - Sash overlap / B - Sash groove position
 ** - for decorative covers in other colors look at p. 28.

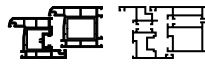

Section 1 ▶ Hinges

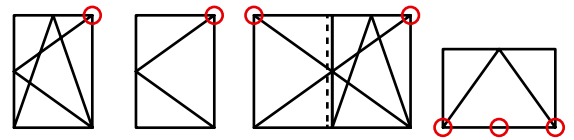

■ **Stay arm bearing 3x3**

■ **Cover of stay arm bearing**

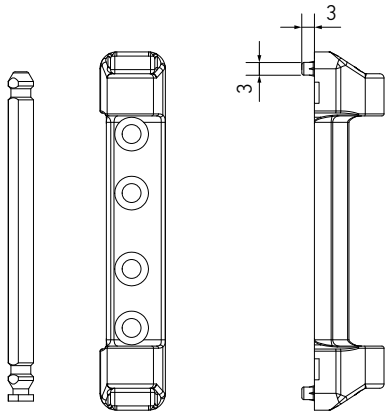

- for appropriate frame stay arm look at p. 49-51, 53;
- for decorative covers in other colors look at p. 28;
- the pin is supplied with hinge.

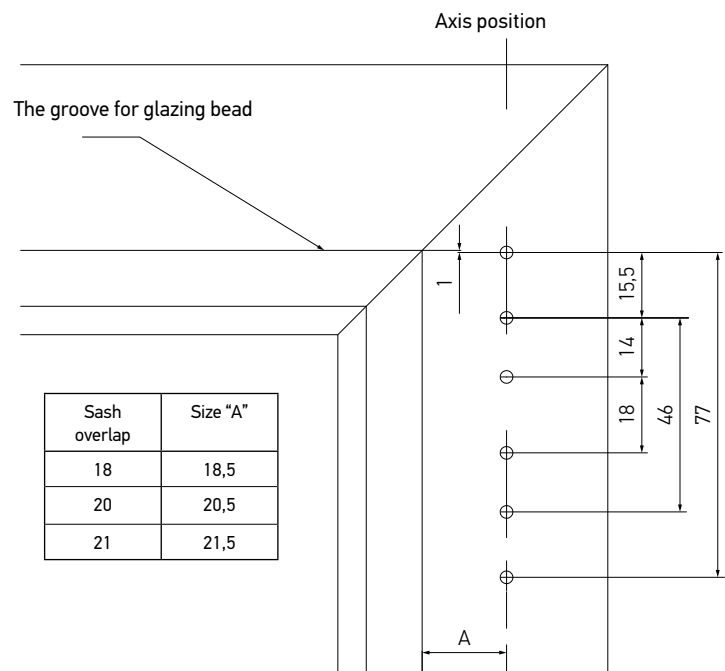

Description	A	C	B	kg			Part No.
Stay arm bearing 3x3	12	20	9/13	100	4 / 3,9x40	250	A5001-00-N03
Cover of stay arm bearing	—	—	—	—	—	500	A7005-10-N**
Description	A	C	B	kg			Part No.
Drilling jig for frame hinges	12	20	—	—	∅3	10	A7002-00-N09
Drilling jig for frame hinges	12	21	—	—	∅3	10	A7002-20-N09

A - Sash rebate gap / C - Sash overlap / B - Sash groove position
 ** - for decorative covers in other colors look at p. 28



Section 1 ▶ Hinges

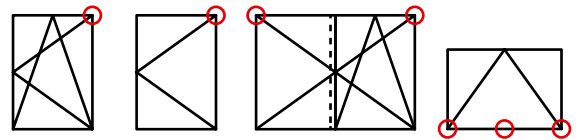

■ **Stay arm bearing 6x24**

■ **Cover of stay arm bearing**

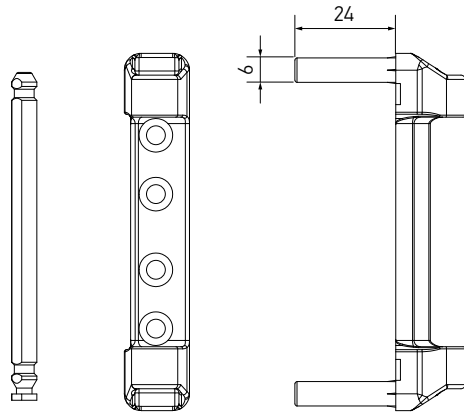

- for appropriate frame stay arm look at p. 49-51, 53;
- for decorative covers in other colors look at p. 28;
- the pin is supplied with hinge .

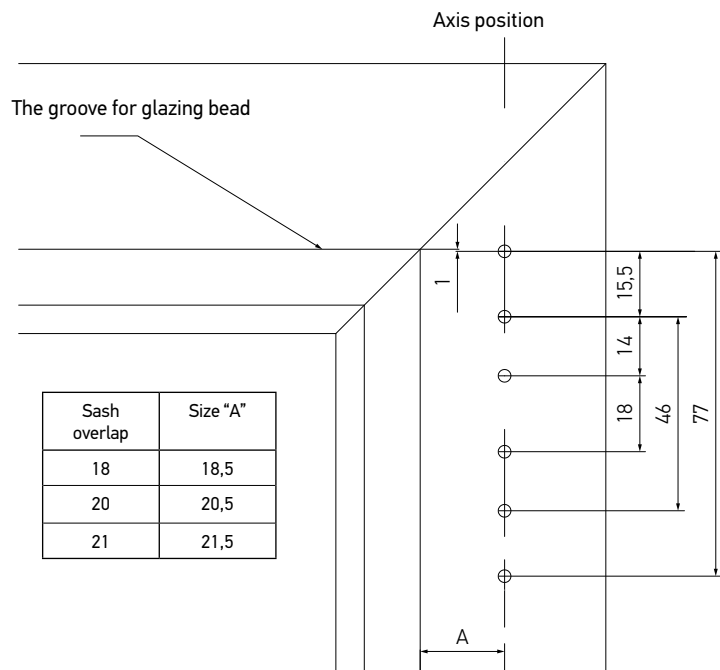

Description	A	C	B	kg			Part No.
Stay arm bearing 6x24	12	20	9/13	130	4 / 3,9x40	250	A5005-00-N03
Cover of stay arm bearing	—	—	—	—	—	500	A7005-10-N**
Description	A	C	B	kg			Part No.
Drilling jig for frame hinges	12	20	—	—	Ø3/6	10	A7002-10-N09
Drilling jig for frame hinges	12	21	—	—	Ø3/6	10	A7002-30-N09

A - Sash rebate gap / C - Sash overlap / B - Sash groove position
 ** - for decorative covers in other colors look at p. 28

Section 1 ▶ Hinges

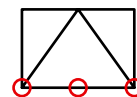

■ Bottom hinges for tilt sash

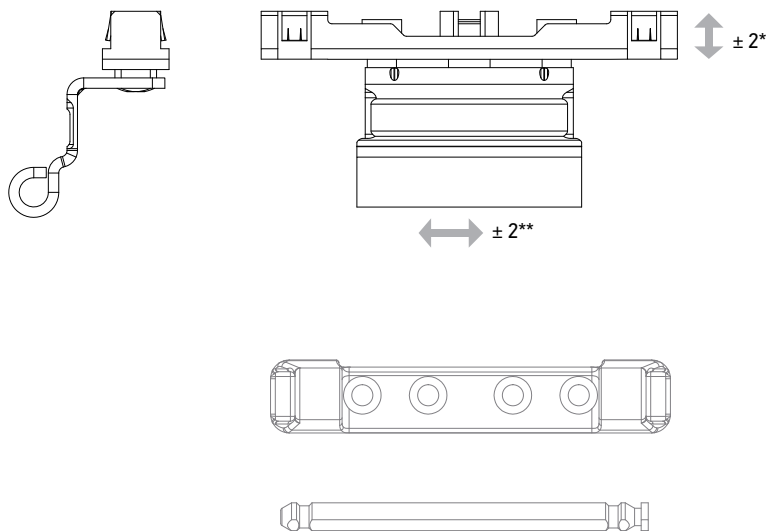

■ Cover of top sash hinge

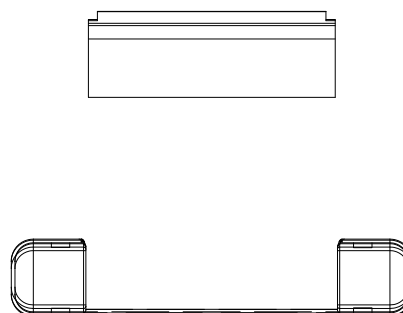

■ for decorative covers in other colors look at p. 28;

* vertical adjustment, mm

** horizontal adjustment, mm

Description	A	C	B	kg			Part No.
Bottom hinges for tilt sash 12/20-13	12	20	13	50*	2 / 4x25	100	A7014-13-N03
Bottom hinges for tilt sash 12/20-9	12	20	9	50*	2 / 4x25	100	A7014-09-N03
Description	A	C	B	kg			Part No.
Cover of top sash hinge	—	—	—	—	—	500	A7004-10-N**

A - Sash rebate gap / C - Sash overlap / B - Sash groove position

* - for 2-hinges set

** - for decorative covers in other colors look at p. 28



Section 1 ▶ Hinges

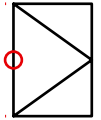

■ **Middle hinge**

■ **Cover of top sash hinge**

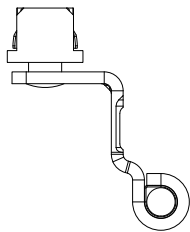
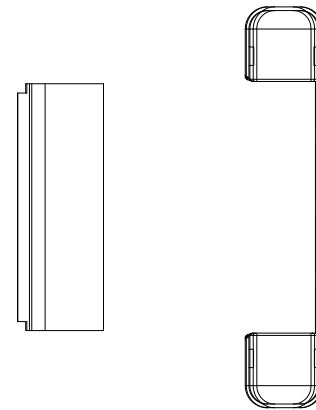
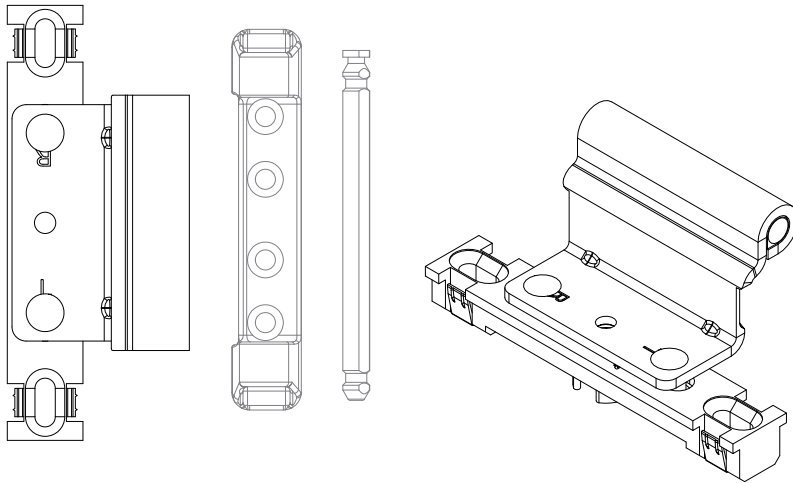

■ for decorative covers in other colors look at p. 28;









Description	A	C	B	kg			Part No.
Middle hinge 12/20-9	12	20	9	50*	2 / 4x25	100	A7030-09-N03
Middle hinge 12/20-13	12	20	13	50*	2 / 4x25	100	A7030-13-N03
Description	A	C	B	kg			Part No.
Cover of top sash hinge	—	—	—	—	—	500	A7004-10-N**

A - Sash rebate gap / C - Sash overlap / B - Sash groove position

* - for 2-hinges set

** - for decorative covers in other colors look at p. 28

Section 1 ▶ Hinges
■ Covers

Description	Sketch	Color		Part No.
Cover of top sash hinge		White RAL 9016	500	A7004-10-N01
		Brown RAL 8022	500	A7004-10-N02
		Silver F1	500	A7004-10-N03
		Cream RAL 9001	500	A7004-10-N04
		Gold F3	500	A7004-10-N05
		Bronze F4	500	A7004-10-N06
		Black RAL 9005	500	A7004-10-N07
Cover of stay arm bearing		White RAL 9016	500	A7005-10-N01
		Brown RAL 8022	500	A7005-10-N02
		Silver F1	500	A7005-10-N03
		Cream RAL 9001	500	A7005-10-N04
		Gold F3	500	A7005-10-N05
		Bronze F4	500	A7005-10-N06
		Black RAL 9005	500	A7005-10-N07
Cover of the drill-in corner hinge		White RAL 9016	500	A7006-10-N01
		Brown RAL 8022	500	A7006-10-N02
		Silver F1	500	A7006-10-N03
		Cream RAL 9001	500	A7006-10-N04
		Gold F3	500	A7006-10-N05
		Bronze F4	500	A7006-10-N06
		Black RAL 9005	500	A7006-10-N07
Bottom cover of corner bearing		White RAL 9016	500	A7007-10-N01
		Brown RAL 8022	500	A7007-10-N02
		Silver F1	500	A7007-10-N03
		Cream RAL 9001	500	A7007-10-N04
		Gold F3	500	A7007-10-N05
		Bronze F4	500	A7007-10-N06
		Black RAL 9005	500	A7007-10-N07
Top cover of corner bearing		White RAL 9016	500	A7008-10-N01
		Brown RAL 8022	500	A7008-10-N02
		Silver F1	500	A7008-10-N03
		Cream RAL 9001	500	A7008-10-N04
		Gold F3	500	A7008-10-N05
		Bronze F4	500	A7008-10-N06
		Black RAL 9005	500	A7008-10-N07
Cover of rebate corner hinge		White RAL 9016	500	A7009-10-L01/R01
		Brown RAL 8022	500	A7009-10-L02/R02
		Silver F1	500	A7009-10-L03/R03
		Cream RAL 9001	500	A7009-10-L04/R04
		Gold F3	500	A7009-10-L05/R05
		Bronze F4	500	A7009-10-L06/R06
		Black RAL 9005	500	A7009-10-L07/R07
Cover of rebate corner hinge	 	White RAL 9016	500	A7085-00-L01/R01
		Brown RAL 8022	500	A7085-00-L02/R02
		Silver F1	500	A7085-00-L03/R03
		Cream RAL 9001	500	A7085-00-L04/R04
		Gold F3	500	A7085-00-L05/R05
		Bronze F4	500	A7085-00-L06/R06
		Black RAL 9005	500	A7085-00-L07/R07

[2]

SMART LINE S+

Gears

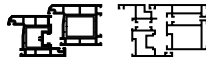

Section 2 ▶ Gears

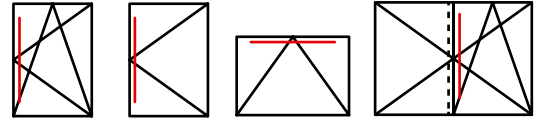

■ Tilt and turn variable gear

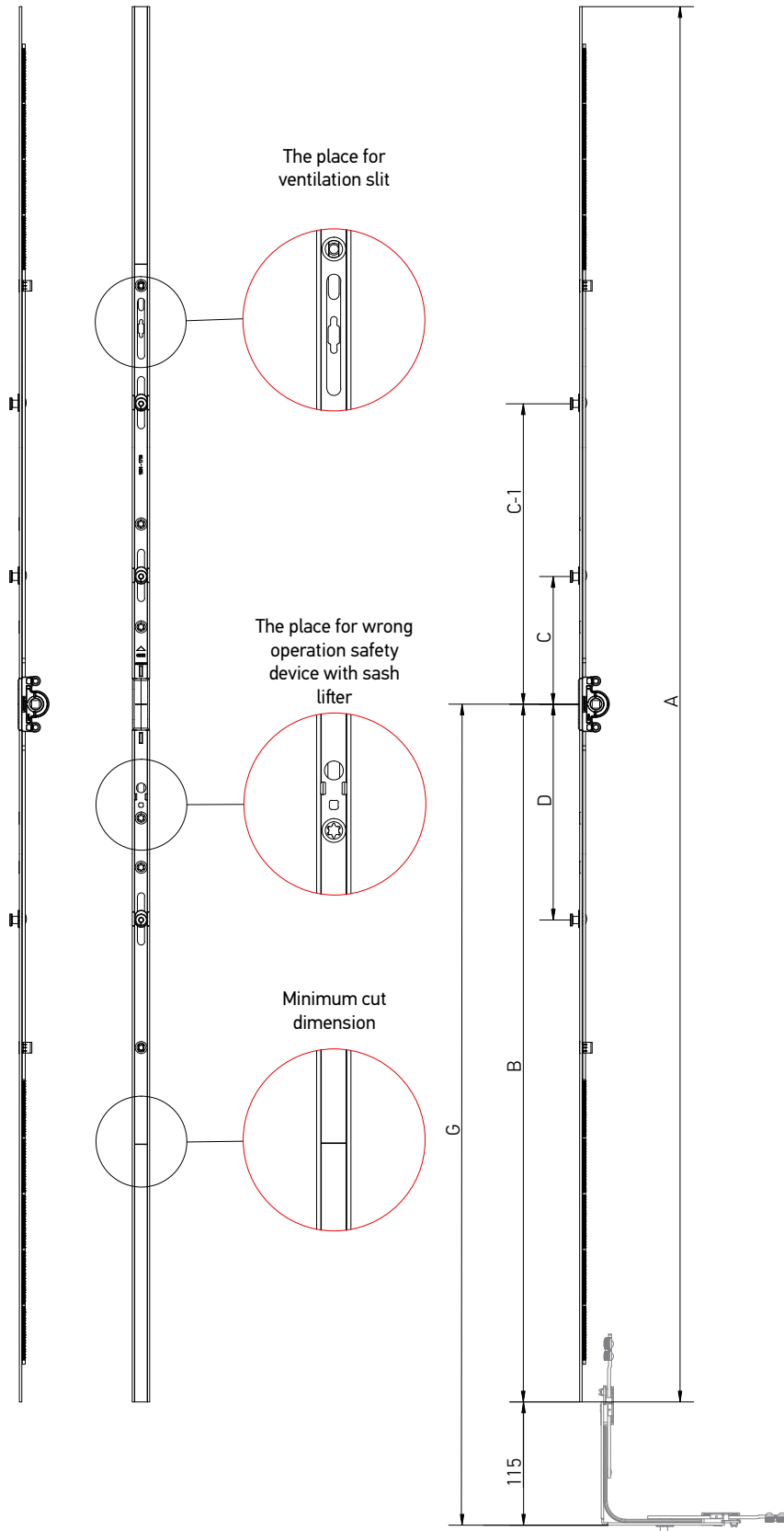

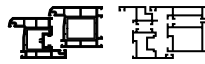

Section 2 ▶ Gears

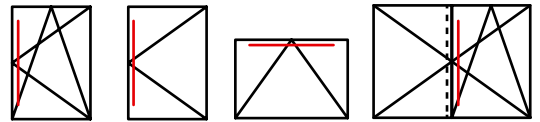

■ Tilt and turn variable gear

Description	SRH (mm)	Dimensions									Part No.
		G	A	B	C	C-1	D				
Tilt and turn variable gear 0, L=320, 450-550*	450-550	225-275	320	160	0	0	0	0	0	25	S1001-02-N03
Tilt and turn variable gear 1, L=520, 551-750*	551-750	275-375	520	260	0	0	0	0	2	25	S1001-04-N03
Tilt and turn variable gear 2, L=1000, 751-1230, 1 ML	751-1230	375-615	1000	500	120	0	0	1	4	25	S1001-09-N03
Tilt and turn variable gear 3, L=1200, 950-1430, 1 ML**	950-1430	475-715	1200	600	120	0	0	1	5	25	S1001-11-N03
Tilt and turn variable gear 4, L=1480, 1231-1710, 2 ML**	1231-1710	615-855	1480	740	120	0	290	2	6	25	S1001-15-N03
Tilt and turn variable gear 5, L=1680, 1431-1910, 2 ML**	1431-1910	715-955	1680	840	265	0	390	2	7	10	S1001-16-N03
Tilt and turn variable gear 6, L=2160, 1911-2390, 3 ML**	1911-2390	955-1195	2160	1080	120	595	490	3	11	10	S1001-21-N03

* there is not a place for the micro lift;

** there is a place for ventilation slit;

- handle position is variable/central;

- backset 15 mm.

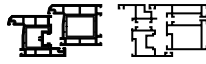

Section 2 ▶ Gears

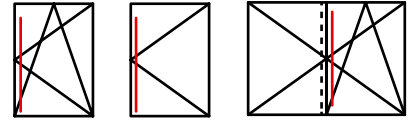

■ Constant tilt & turn gear

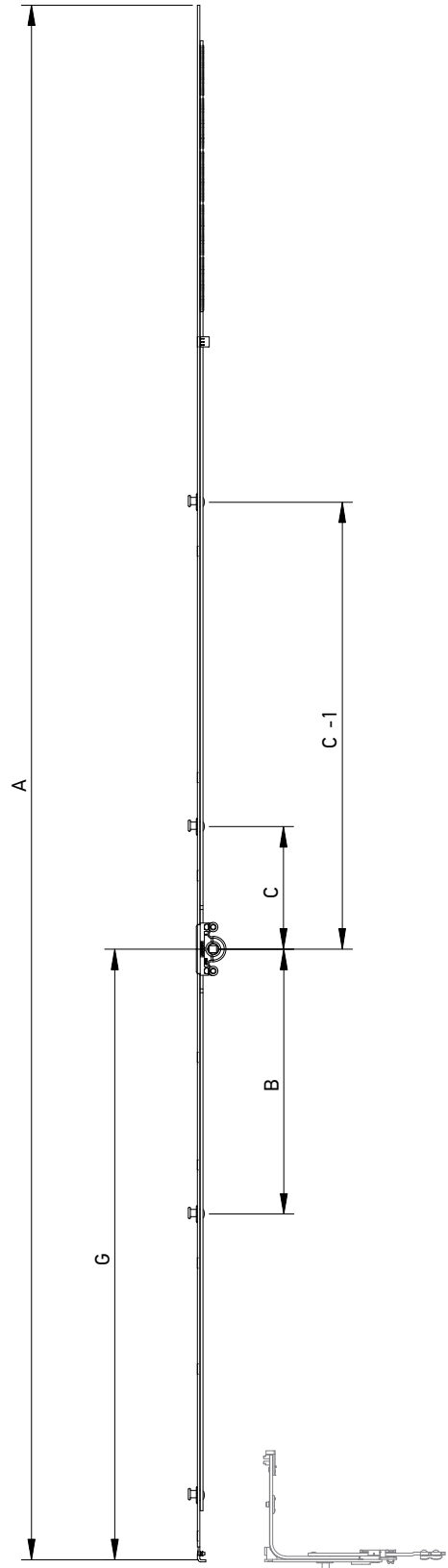
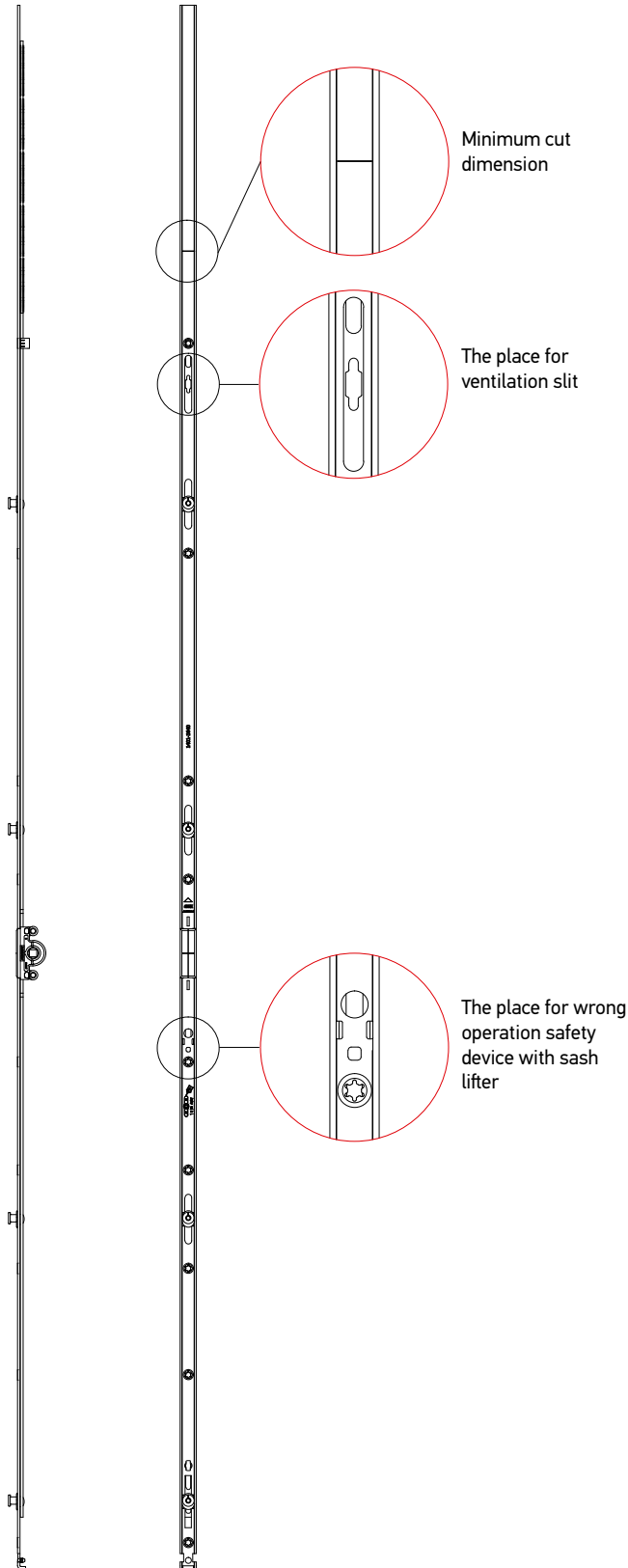

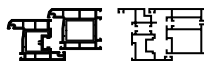

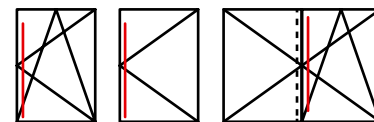

Section 2 ▶ Gears



■ Constant tilt & turn gear

Description	SRH (mm)	Dimensions								Part No.
		G	A	B	C	C-1				
Constant gear 1, L=385, G=175, 400-500*	400-500	175	385	-	-	-	0	2	20	S1003-03-N03
Constant gear 2, L=565, G=200, 480-680*	480-680	200	565	-	-	-	0	3	20	S1003-05-N03
Constant gear 3, L=805, G=300, 681-920	681-920	300	805	-	120	-	1	5	20	S1003-08-N03
Constant gear 4, L=1045, G=450, 921-1160	921-1160	450	1045	-	120	-	1	5	20	S1003-10-N03
Constant gear 5, L=1285, G=600, 1161-1400**	1161-1400	600	1285	-	120	-	1	7	20	S1003-12-N03
Constant gear 6, L=1525, G=600, 1401-1640**	1401-1640	600	1525	-	120	438	2	8	20	S1003-15-N03
Constant gear 7, L=1765, G=600, 1641-1880**	1641-1880	600	1765	-	120	643	2	9	10	S1003-17-N03
Constant gear 8, L=1765, G=1000, 1641-1880**	1641-1880	1000	1765	280	263	-	2	10	10	S1003-18-N03
Constant gear 9, L=2005, G=1000, 1881-2120**	1881-2120	1000	2005	280	387	-	2	11	10	S1003-20-N03
Constant gear 10, L=2245, G=1000, 2121-2360**	2121-2360	1000	2245	280	120	723	3	13	10	S1003-22-N03

* there is not a place for the micro lif

** there is a place for ventilation slit;
- backset 15 mm.

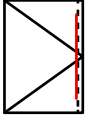

Section 2 ▶ Gears

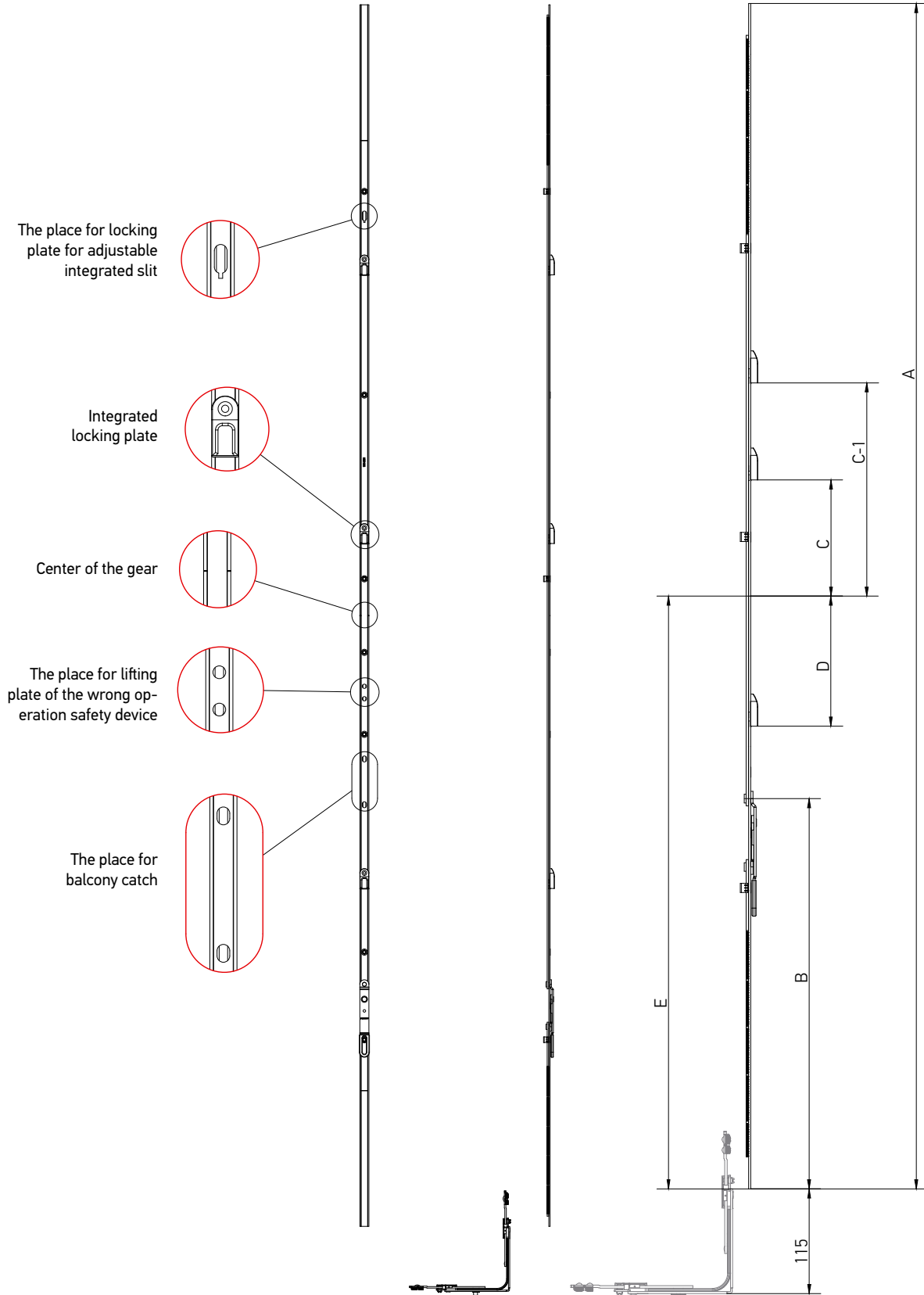

■ Double sash gear with opposite stroke for handle's center position at main sash

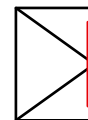

Section 2 ▶ Gears

■ Double sash gear with opposite stroke for handle's center position at main sash

Description	SRH (mm)	Dimensions									Part No.
		A	B	C	D	C-1	E				
Double sash lever espagnolete variable 1 L=520, 551-750*	551-750	520	225	0	0	0	260	0	2	25	S1002-05-N03
Double sash lever espagnolete variable 2 L=720, 751-950**	751-950	720	428	129,5	0	0	360	1	2	25	S1002-07-N03
Double sash lever espagnolete variable 3 L=1200, 951-1430**	951-1430	1200	428	129,5	0	0	600	1	3	25	S1002-12-N03
Double sash lever espagnolete variable 4 L=1680, 1431-1910** (***)	1431-1910	1680	428	274,5	380,5	0	840	2	4	10	S1002-17-N03
Double sash lever espagnolete variable 5 L=2160, 1911-2390** (***)	1911-2390	2160	428	129,5	480,5	604,5	1080	3	6	10	S1002-22-N03

* there is not a place for the micro lif

** there is a place for ventilation slit

*** there is a place for balcony catch

[3]

SMART LINE S+

Corner transmissions / Middle locks / Extensions

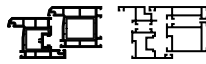



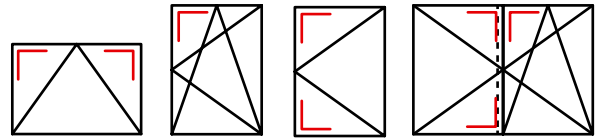

Section 3 ▶ Corner transmissions / Middle locks / Extensions

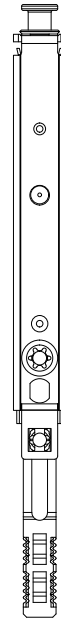
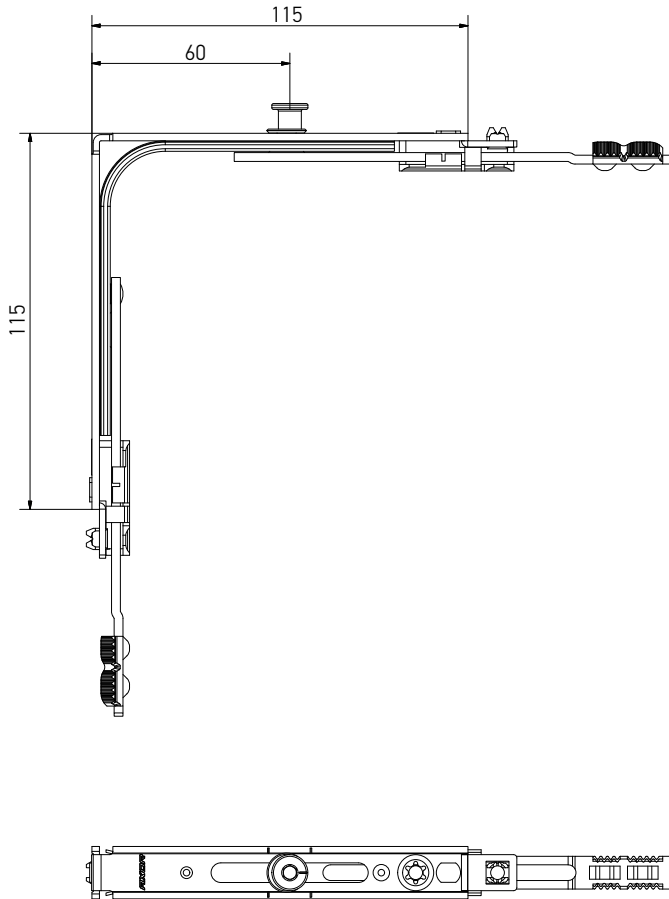

■ Corner transmission standard

- Recommended



Description	Application range					Part No.
	SRW (mm)	SRH (mm)				
Corner transmission standard	400-1280	450-2390	1	4	50	S2001-00-N03

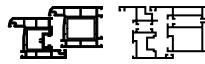

Section 3 ▶ Corner transmissions/ Middle locks/ Extensions

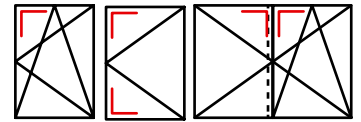

■ **Corner transmission 2 ML**

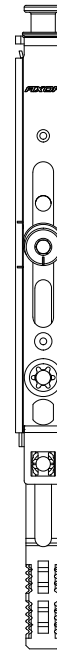
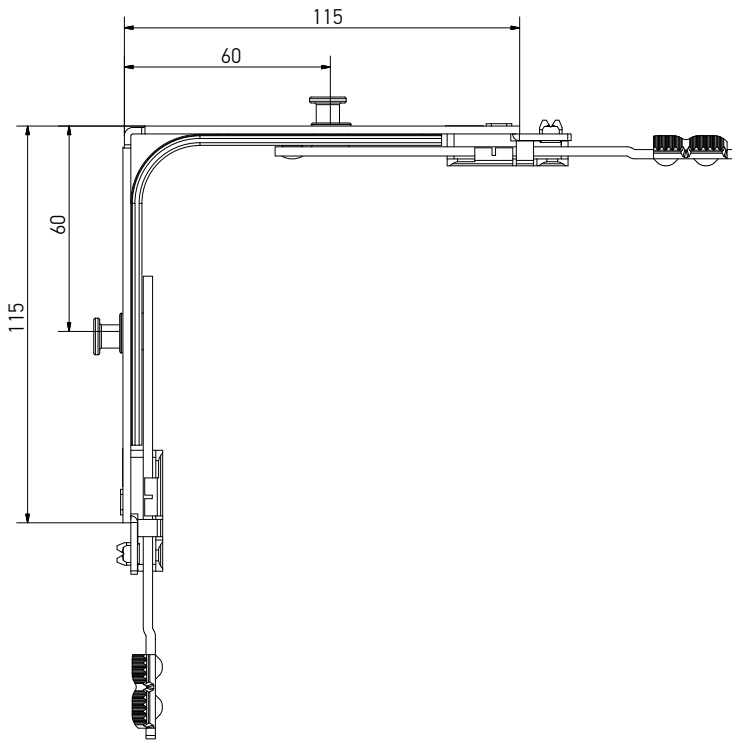

Description	Application range					Part No.
	SRW (mm)	SRH (mm)				
Corner transmission 2 ML	400-1280	450-2390	2	4	50	S2002-00-N03

Section 3 ▶ Corner transmissions/ Middle locks/ Extensions

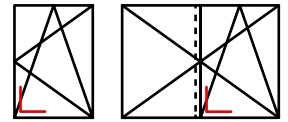

■ **Corner transmission, bottom**

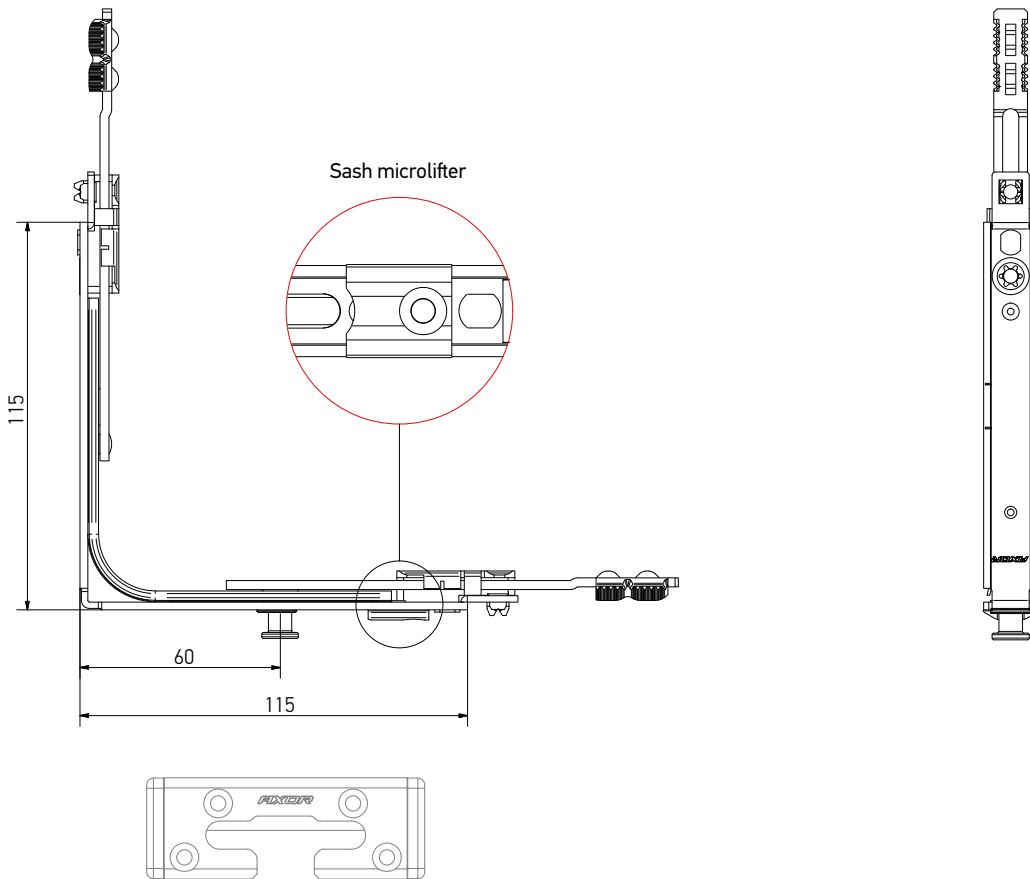

Description	Application range					Part No.
	SRW (mm)	SRH (mm)				
Corner transmission, bottom	400-1280	450-2390	1	4	50	S2006-00-N03

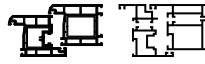



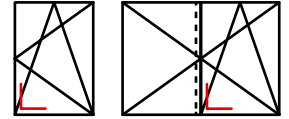

Section 3 ▶ Corner transmissions/ Middle locks/ Extensions

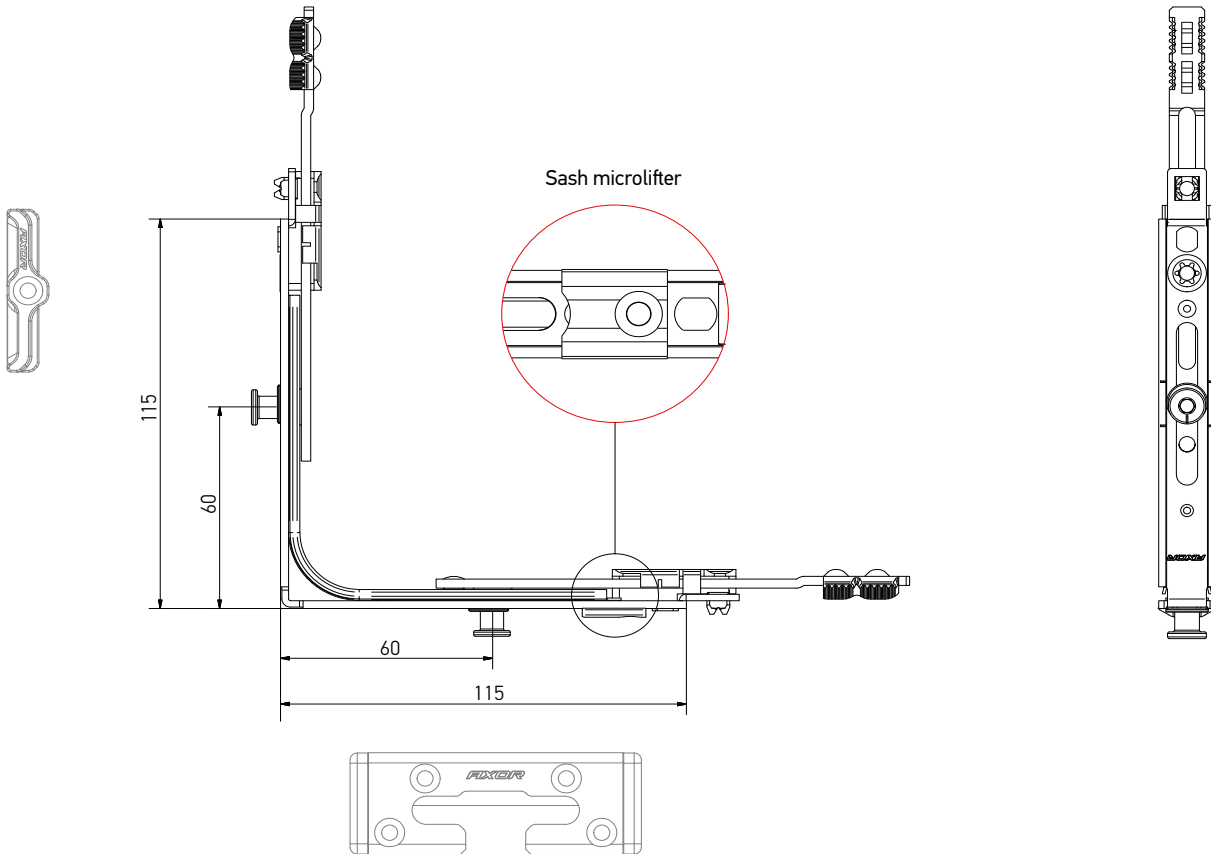

■ Corner transmission 2 ML, bottom

- Recommended



Description	Application range					Part No.
	SRW (mm)	SRH (mm)				
Corner transmission 2 ML, bottom	400-1280	450-2390	2	4	50	S2007-00-N03

Section 3 ▶ Corner transmissions/ Middle locks/ Extensions

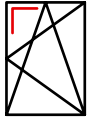

■ **Corner transmission, integrated slit**

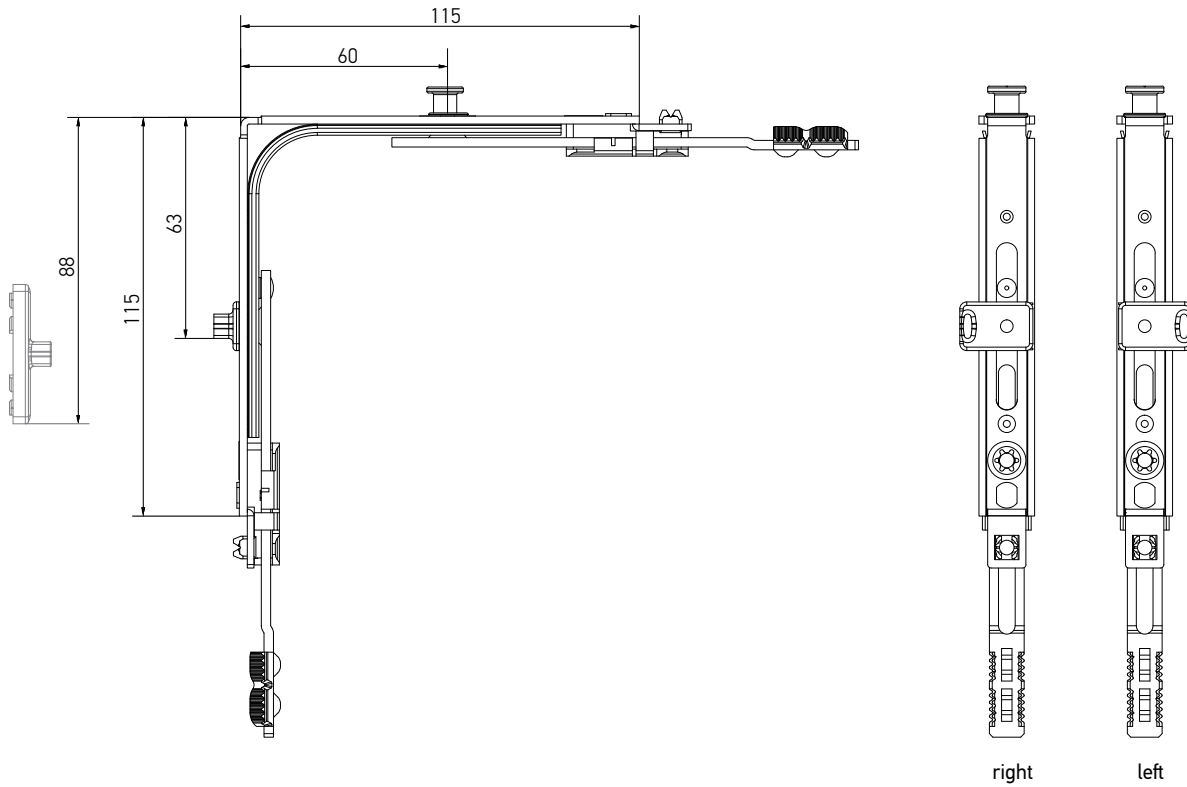

Description	Application range		Side opening				Part No.
	SRW (mm)	SRH (mm)					
Corner transmission, integrated slit, left	400-1280	450-2390	L	1	4	50	S2004-00-L03
Corner transmission, integrated slit, right	400-1280	450-2390	R	1	4	50	S2004-00-R03
Locking plate for adjustable integrated slit	400-1280	450-2390	—	—	2	250	A6004-00-N03

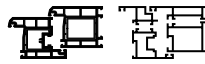



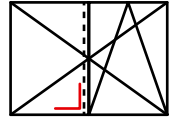

Section 3 ▶ Corner transmissions/ Middle locks/ Extensions

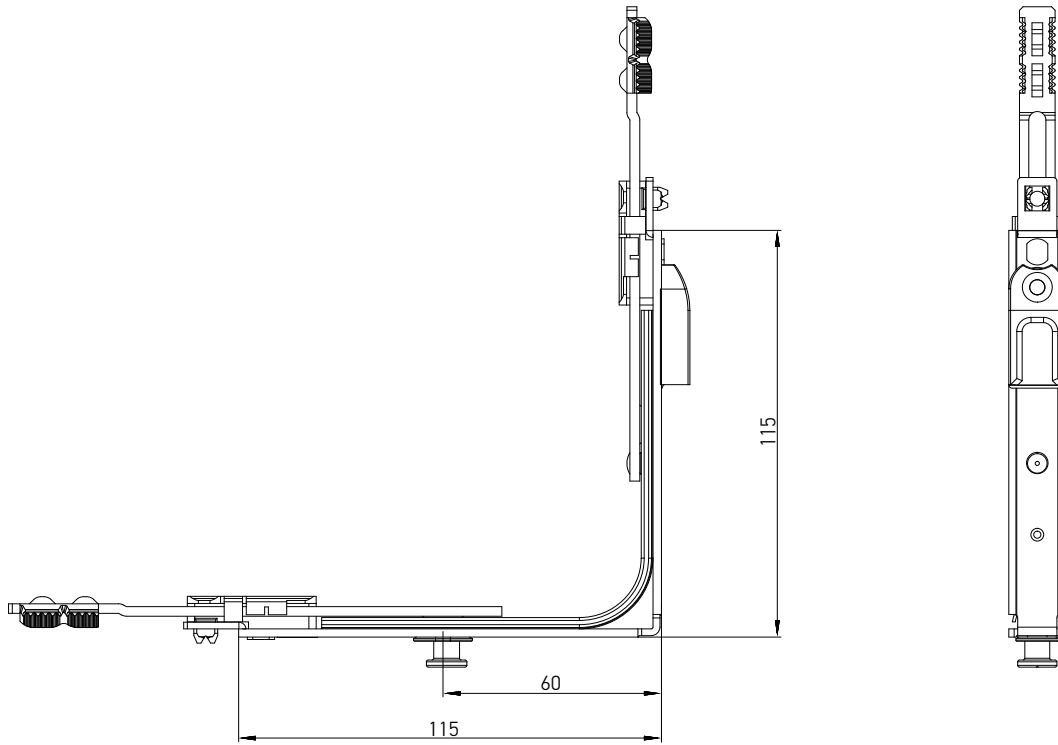

■ **Corner transmission, double sash, bottom**

- Recommended



Description	Application range					Part No.
	SRW (mm)	SRH (mm)				
Corner transmission, double sash, bottom	400-1280	550-2390	1	4	50	S2005-00-N03

Section 3 ▶ Corner transmissions/ Middle locks/ Extensions

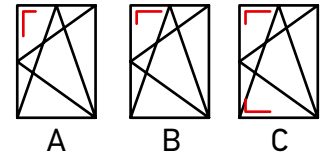

■ **Corner transmission s**

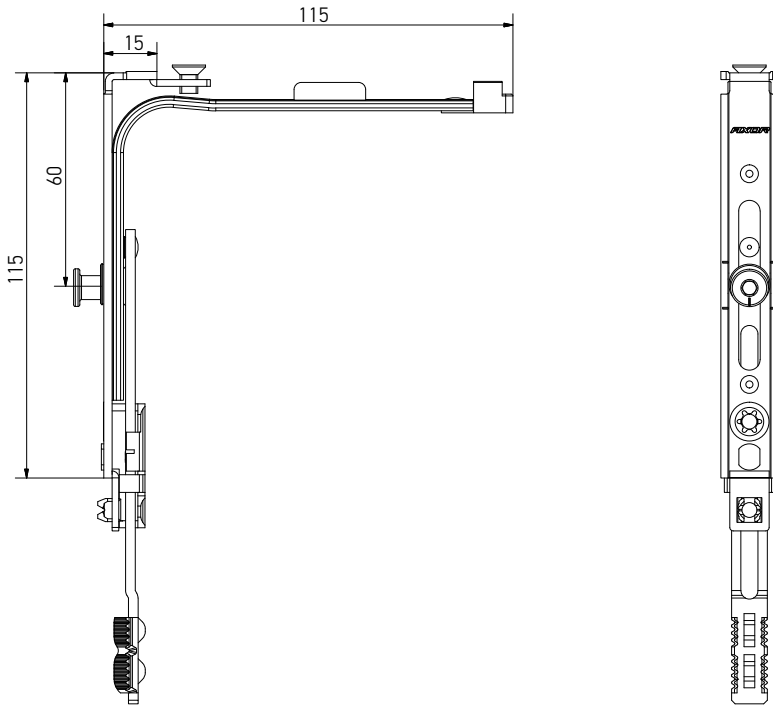

- Not intended for double-sash windows;
- In order to use the narrow corner transmission according to scheme B the distance from the bottom of the fitting groove to the handle axis should be 225 mm, i.e. a hole for handle on gear S1001-02-N03 is displaced from the center of the sash in application range of the sash's height 390-450 mm.

Description	Side opening	Application range					Part No.
		SRW (mm)	SRH (mm)				
Corner transmission s	A	300-400	450-2390	1	4	25	S2003-00-N03
Corner transmission s	B	400-600	350-450	1	4	25	S2003-00-N03
Corner transmission s	C	400-600	250-350	1	4	25	S2003-00-N03

Section 3 ▶ Corner transmissions/ Middle locks/ Extensions

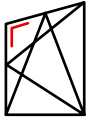

■ **Corner transmission for oblique window**

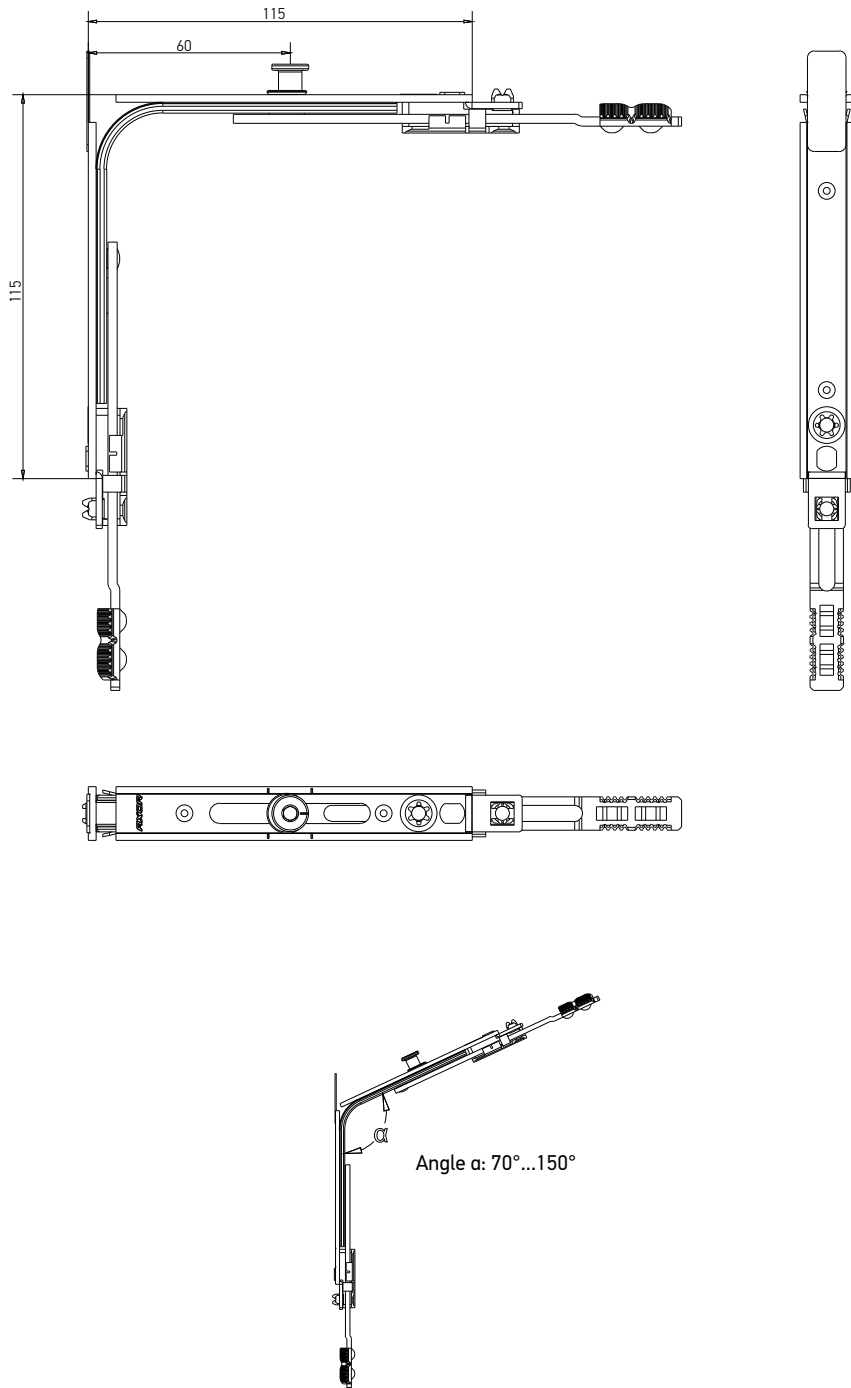



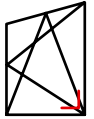

Description	Application range					Part No.
	SRW (mm)	SRH (mm)				
Corner transmission for oblique window	400-1280	450-2390	1	4	50	S2008-00-N03

Section 3 ▶ Corner transmissions/ Middle locks/ Extensions

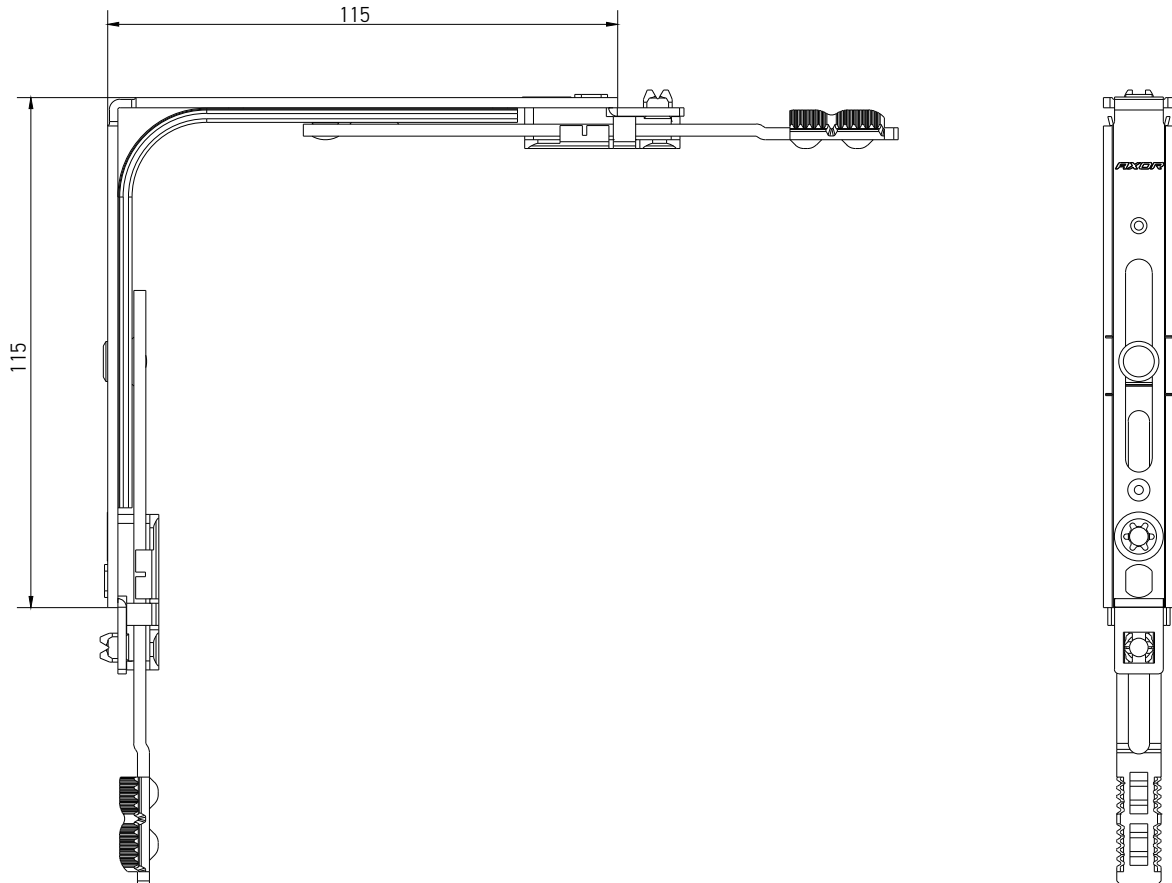

■ **Corner transmission without ML**



Description	Application range					Part No.
	SRW (mm)	SRH (mm)				
Corner transmission without ML	400-1280	450-2390	—	4	50	S2009-00-N03

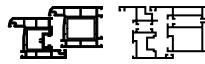

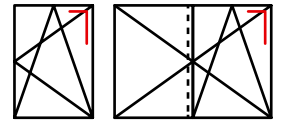

Section 3 ▶ Corner transmissions/ Middle locks/ Extensions

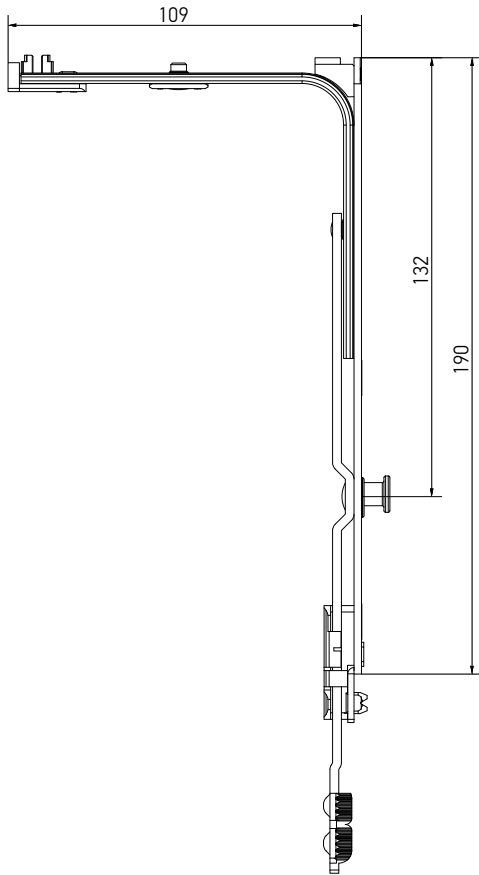

■ **Middle lock vertical**



Description	Application range					Part No.
	SRW (mm)	SRH (mm)				
Middle lock vertical	-	450-2390	1	3	50	S4001-00-N03

Section 3 ▶ Corner transmissions/ Middle locks/ Extensions

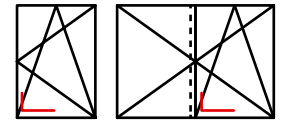

■ **Middle lock short**

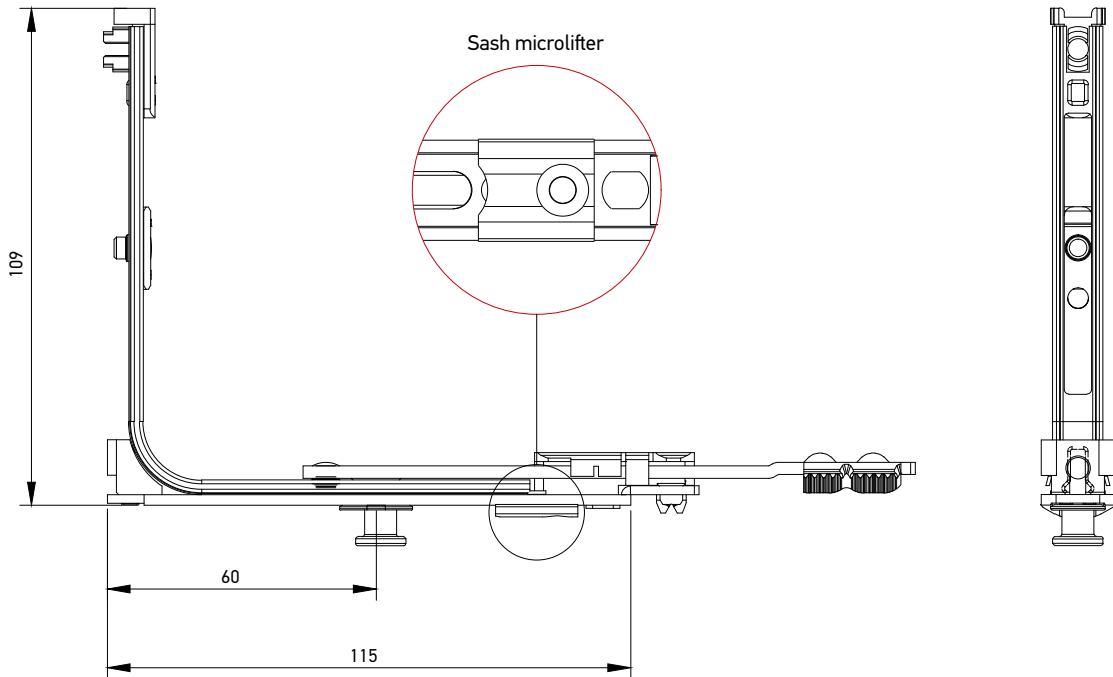

Description	Application range					Part No.
	SRW (mm)	SRH (mm)				
Middle lock short	400-1280	-	1	3	50	S4004-00-N03

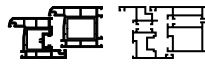

Section 3 ▶ Corner transmissions/ Middle locks/ Extensions

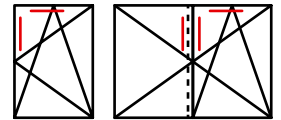

■ **Extension**

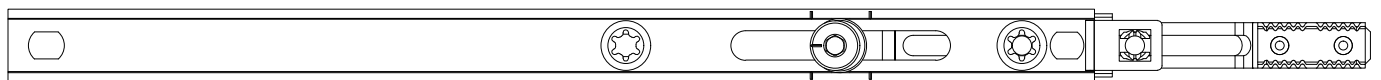
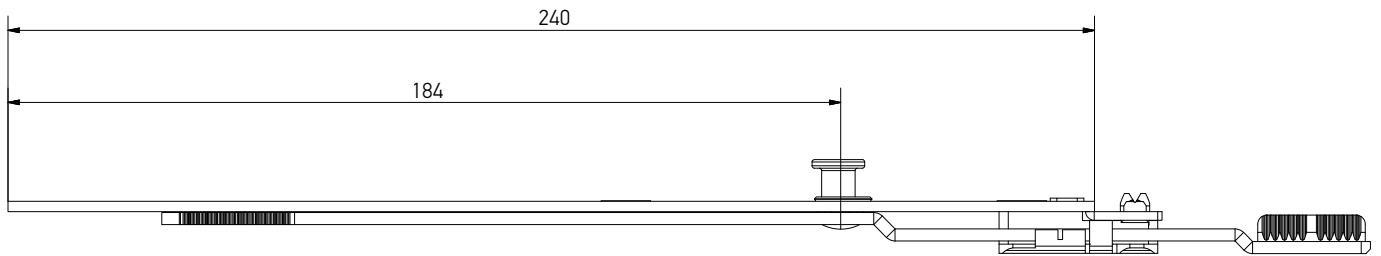

Description	Dimensions				Part No.
Extension	240	1	2	25	S4003-02-N03

Section 3 ▶ Corner transmissions/ Middle locks/ Extensions

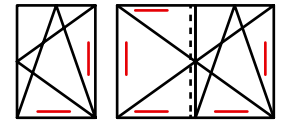

■ **Middle lock extension**

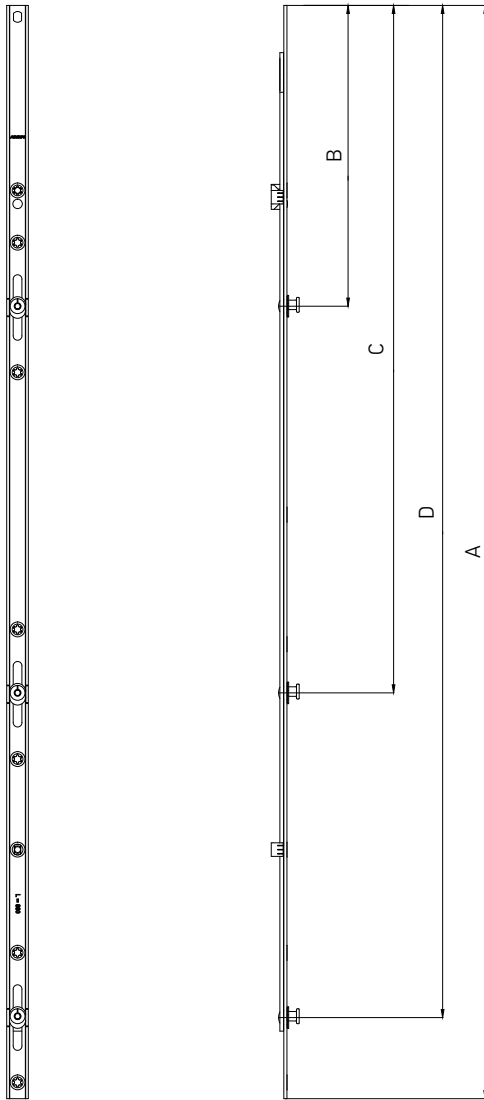

Description	SRW (mm)	SRH (mm)	Dimensions							Part No.
			A	B	C	D				
Middle lock extension L=480	800-1140	850-1230	485	425	—	—	1	4	20	S4002-05-N03
Middle lock extension L=680	1121-1340	1231-1430	685	625	—	—	1	5	20	S4002-07-N03
Middle lock extension L=880	1321-1520	1431-1710	885	425	825	—	2	7	20	S4002-09-N03
Middle lock extension L=1040	—	1711-1910	1045	425	985	—	2	7	20	S4002-10-N03
Middle lock extension L=1530	—	1911-2390	1535	425	985	1475	3	10	10	S4002-15-N03

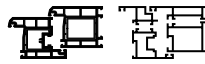

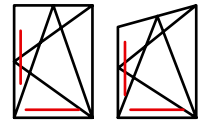

Section 3 ▶ Corner transmissions/ Middle locks/ Extensions

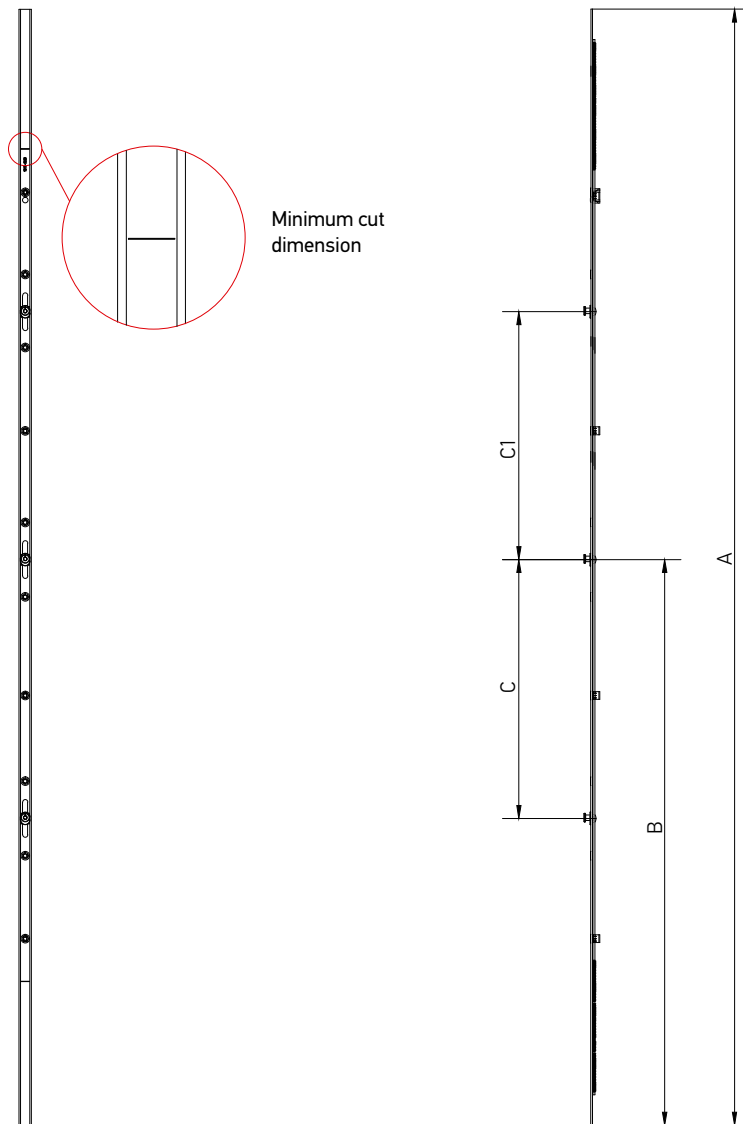

■ **Middle connection**



Description	SRW (mm)	Dimensions							Part No.
		A	B	C	C1				
Middle connection L = 520	551-750	520	260	-	-	-	2	20	S4005-05-N03
Middle connection L = 720	751-950	720	360	-	-	1	4	20	S4005-07-N03
Middle connection L = 1200	951-1430	1200	600	-	-	1	4	20	S4005-12-N03
Middle connection L = 1680	1431-1910	1680	840	330	330	2	8	10	S4005-17-N03
Middle connection L = 2160	1911-2390	2160	1080	595	595	3	10	10	S4005-22-N03

SMART LINE S+

[4]

Stay arm

[4] Stay arm

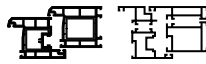

Section 4 ▶ Stay arms

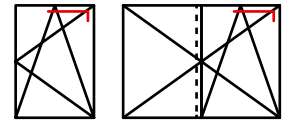

■ Stay arm

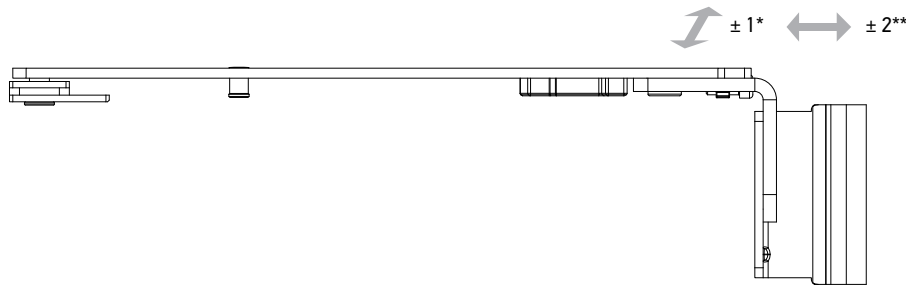

* clamp adjustment, mm

** horizontal adjustment, mm

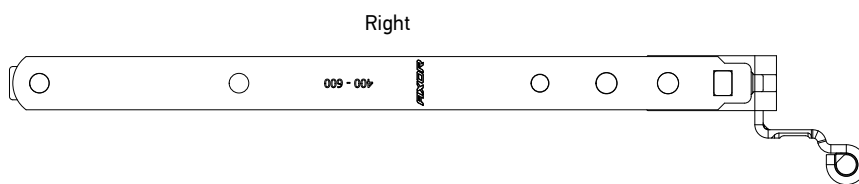
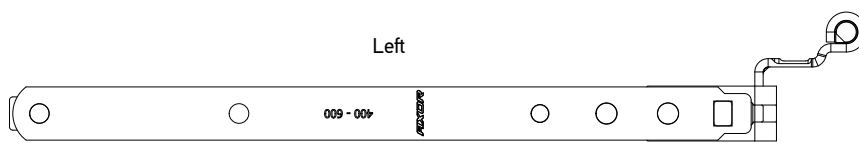

Description	SRW (mm)	Side opening	kg		Part No.
Stay arm 13, L=248, 400-600, left	400-600	L	130	25	S3001-02-L03
Stay arm 13, L=248, 400-600, right	400-600	R	130	25	S3001-02-R03
Stay arm 13, L = 319, 601-800, left	601-800	L	130	25	S3001-03-L03
Stay arm 13, L = 319, 601-800, right	601-800	R	130	25	S3001-03-R03
Stay arm 13, L = 449, 801-1040, left	801-1040	L	130	25	S3001-04-L03
Stay arm 13, L = 449, 801-1040, right	801-1040	R	130	25	S3001-04-R03
Stay arm 13, L = 539, 1041-1280, left	1041-1280	L	130	25	S3001-05-L03
Stay arm 13, L = 539, 1041-1280, right	1041-1280	R	130	25	S3001-05-R03
Stay arm 9, L=248, 400-600, left	400-600	L	130	25	S3002-02-L03
Stay arm 9, L=248, 400-600, right	400-600	R	130	25	S3002-02-R03
Stay arm 9, L = 319, 601-800, left	601-800	L	130	25	S3002-03-L03
Stay arm 9, L = 319, 601-800, right	601-800	R	130	25	S3002-03-R03
Stay arm 9, L = 449, 801-1040, left	801-1040	L	130	25	S3002-04-L03
Stay arm 9, L = 449, 801-1040, right	801-1040	R	130	25	S3002-04-R03
Stay arm 9, L = 539, 1041-1280, left	1041-1280	L	130	25	S3002-05-L03
Stay arm 9, L = 539, 1041-1280, right	1041-1280	R	130	25	S3002-05-R03

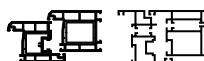

Section 4 ▶ Stay arms

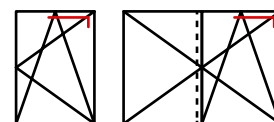

■ Stay arm “First Tilt”

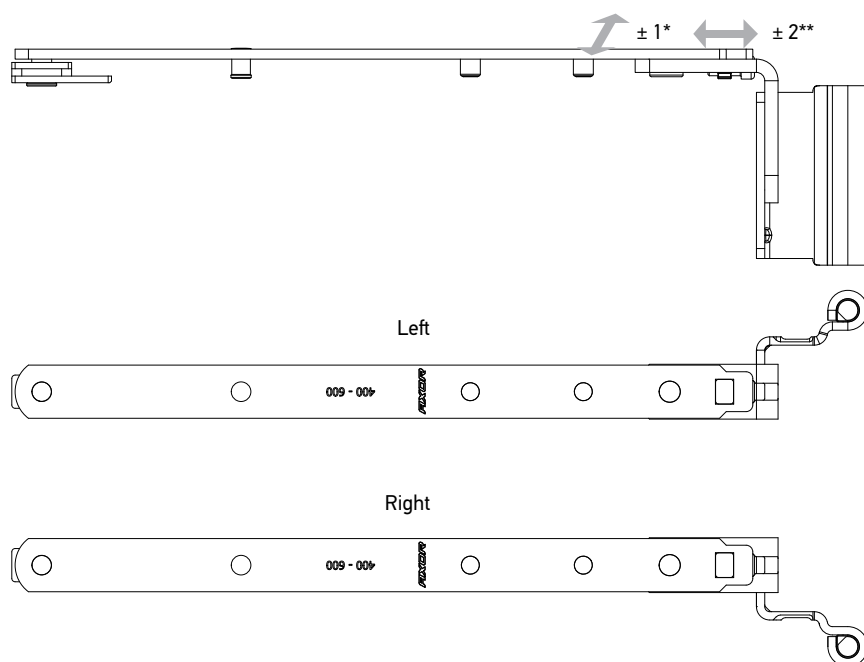

* clamp adjustment, mm

** horizontal adjustment, mm

Description	SRW (mm)	Side opening	kg		Part No.
Stay arm 13, "First Tilt" L = 222, 400-600, left	400-600	L	130	25	S3006-02-L03
Stay arm 13, "First Tilt" L = 222, 400-600, right	400-600	R	130	25	S3006-02-R03
Stay arm 13, "First Tilt" L = 319, 601-800, left	601-800	L	130	25	S3006-03-L03
Stay arm 13, "First Tilt" L = 319, 601-800, right	601-800	R	130	25	S3006-03-R03
Stay arm 13, "First Tilt" L = 449, 801-1040, left	801-1040	L	130	25	S3006-04-L03
Stay arm 13, "First Tilt" L = 449, 801-1040, right	801-1040	R	130	25	S3006-04-R03
Stay arm 13, "First Tilt" L=539, 1041-1280, left	1041-1280	L	130	25	S3006-05-L03
Stay arm 13, "First Tilt" L=539, 1041-1280, right	1041-1280	R	130	25	S3006-05-R03

Section 4 ▶ Stay arms

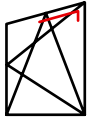

■ **Stay arm for oblique window**

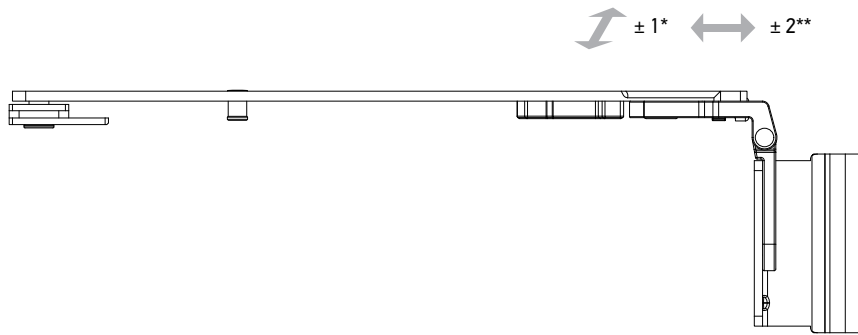

* clamp adjustment, mm

** horizontal adjustment, mm

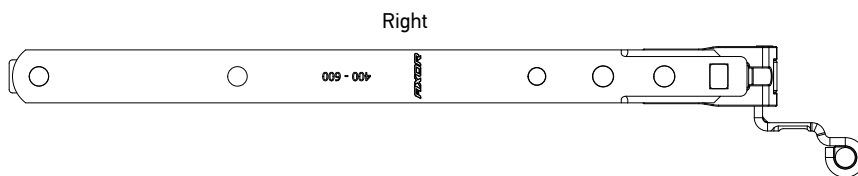
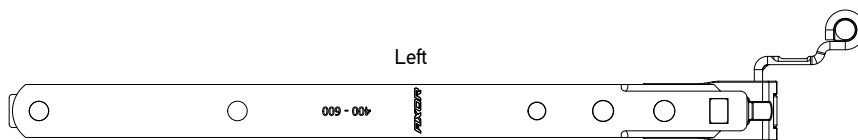

Description	SRW (mm)	Side opening	kg		Part No.
Stay arm for oblique window 13, L=248, 400-600, left	400-600	L	130	25	S3004-02-L03
Stay arm for oblique window 13, L=248, 400-600, right	400-600	R	130	25	S3004-02-R03
Stay arm for oblique window 13, L=319, 601-800, left	601-800	L	130	25	S3004-03-L03
Stay arm for oblique window 13, L=319, 601-800, right	601-800	R	130	25	S3004-03-R03
Stay arm for oblique window 13, L = 449, 801-1040, left	801-1040	L	130	25	S3004-04-L03
Stay arm for oblique window 13, L = 449, 801-1040, right	801-1040	R	130	25	S3004-04-R03
Stay arm for oblique window 13, L = 539, 1041-1280, left	1041-1280	L	130	25	S3004-05-L03
Stay arm for oblique window 13, L = 539, 1041-1280, right	1041-1280	R	130	25	S3004-05-R03

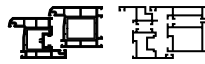



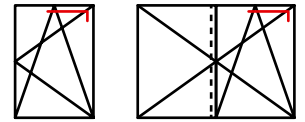

Section 4 ▶ Stay arms

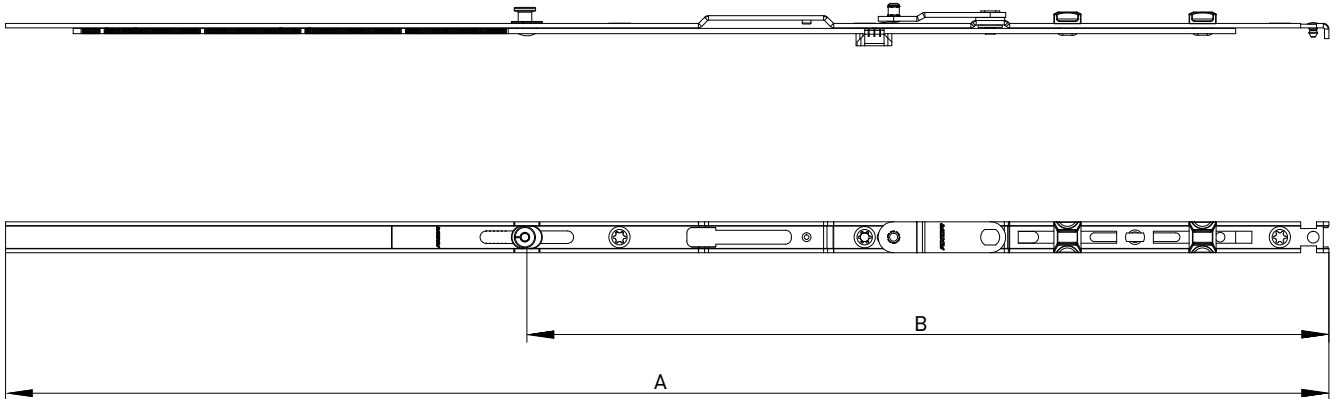

■ Stay arm connecting plate



Description	SRW (mm)	Dimensions						Part No.
		A	B					
Stay arm connecting plate 1 L=485, 400-600	400-600	485	—	0	130	3	25	S3003-05-N03
Stay arm connecting plate 2 L=685, 601-800	601-800	685	390	0	130	4	25	S3003-07-N03
Stay arm connecting plate 2 L=685, 601-800	601-800	685	390	1	130	4	25	S3003-57-N03
Stay arm connecting plate 3 L=925, 801-1040	801-1040	925	538	1	130	6	25	S3003-09-N03
Stay arm connecting plate 4 L=1165, 1041-1280	1041-1280	1165	625	1	130	7	10	S3003-12-N03

Section 4 ▶ Stay arms

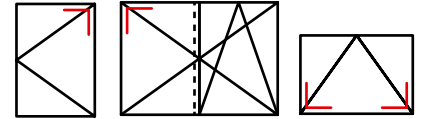



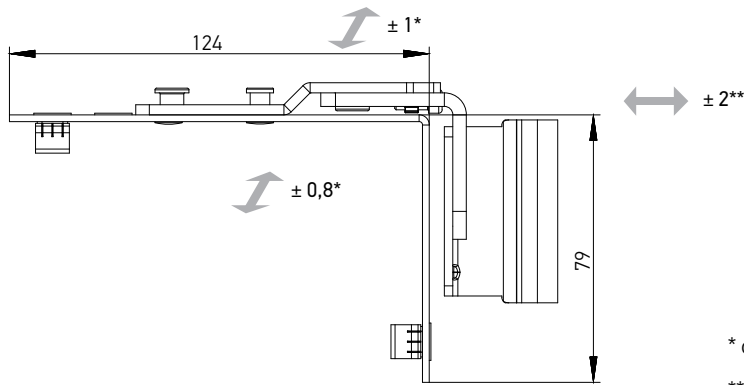

Turn stay arm

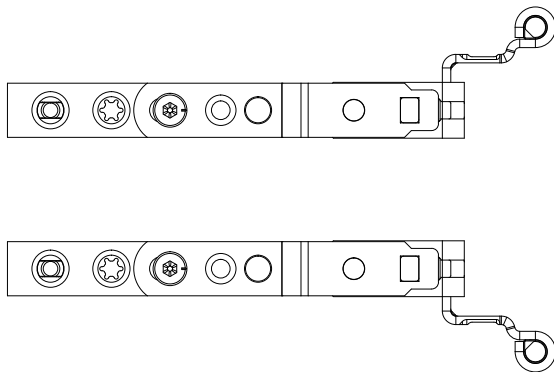

* clamp adjustment, mm

** horizontal adjustment, mm



Description	SRW (mm)					Part No.
Turn stay arm 12/20-13 left	280-1200	0	130	3	25	S5001-13-L03
Turn stay arm 12/20-13 right	280-1200	0	130	3	25	S5001-13-R03
Turn stay arm 12/20-9 left	280-1200	0	130	3	25	S5001-09-L03
Turn stay arm 12/20-9 right	280-1200	0	130	3	25	S5001-09-R03

Section 4 ▶ Stay arms

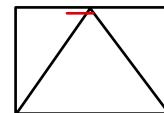

■ Tilt stay arm

General view and stay-arm position at a frame

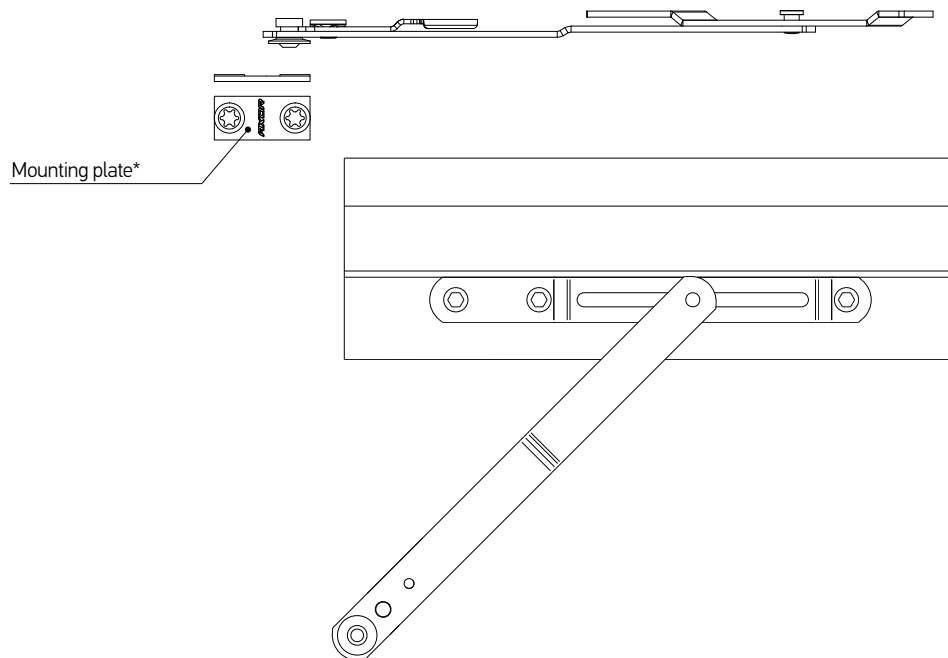

■ Installation information

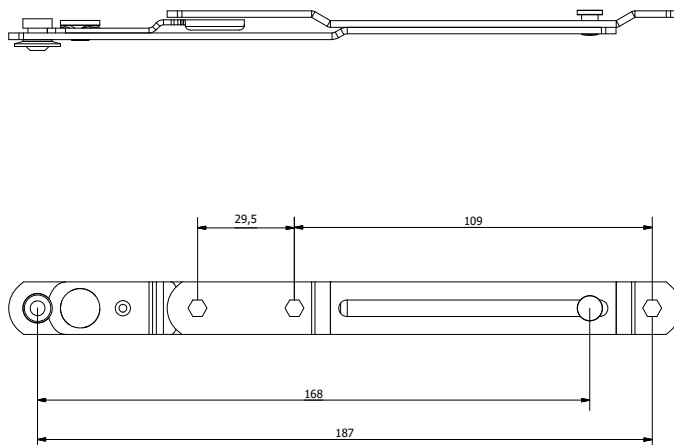

Description	SRW (mm)					Part No.
Tilt stay arm	450-1710	0	3	45	100	A7017-00-N03
Adjustment plate for the tilt stay arm	—	—	—	—	—	A7039-00-N03

* - To install stay arm vertically

SMART LINE S+

[5]

Additional elements

Section 5 ▶ Additional elements

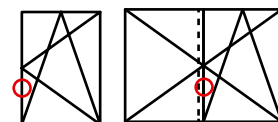

■ **Wrong operation safety device with sash lifter**

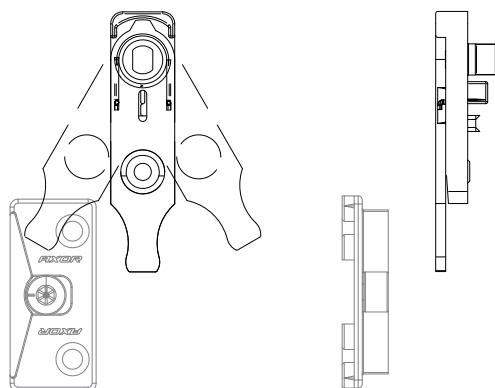

Description	A	C	B			Part No.
Wrong operation safety device with sash lifter	—	—	—	1	100	A7001-00-N03
Lifting plate	Look at the section “Profile-dependent elements”					
Lifting plate for double-sash window	12	20	09-13	2	250	A6001-00-N03
Lifting plate	12	—	9	2	250	A6028-09-N03

* just for aluminum profile, 9 mm.

A - Sash rebate gap / C - Sash overlap / B - Sash groove position

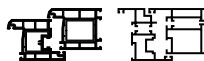

Section 5 ▶ Additional elements

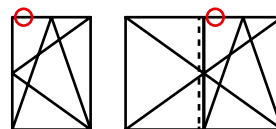

■ Locking plate, integrated slit

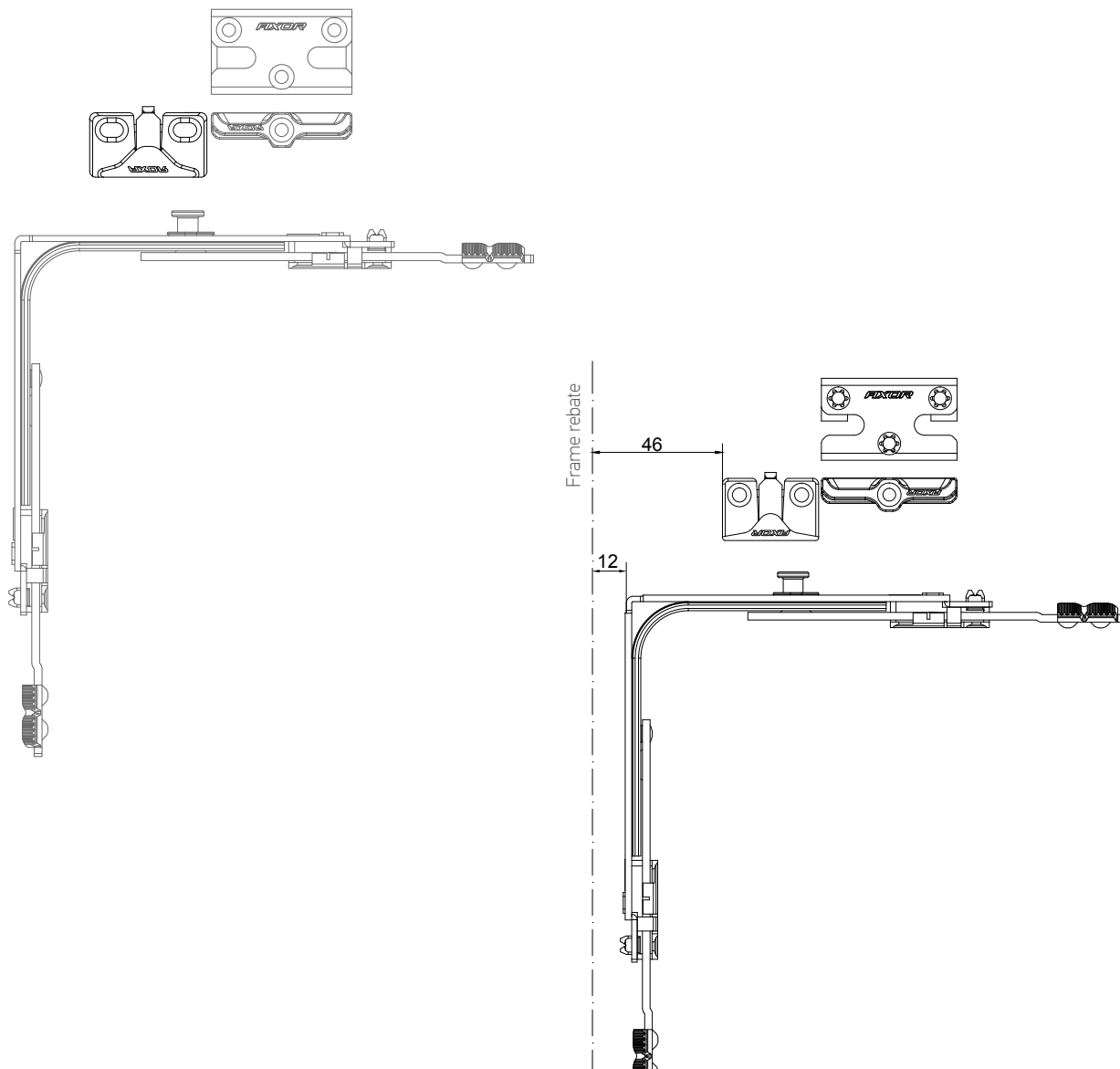

Description	Profile's name	A	C	B			Part No.
Locking plate, integrated slit	Rehau	12	20	13	2	100	A6005-09-N03
Locking plate, integrated slit	WDS 400, 505, 800 (13mm)	12	20	13	2	100	A6002-13-N03
Locking plate, integrated slit	aluminum profile, 9 mm	12	—	9	2	—	A6026-09-N03

A - Sash rebate gap / C - Sash overlap / B - Sash groove position



Section 5 ▶ Additional elements

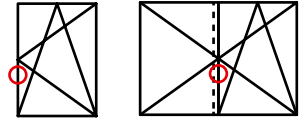

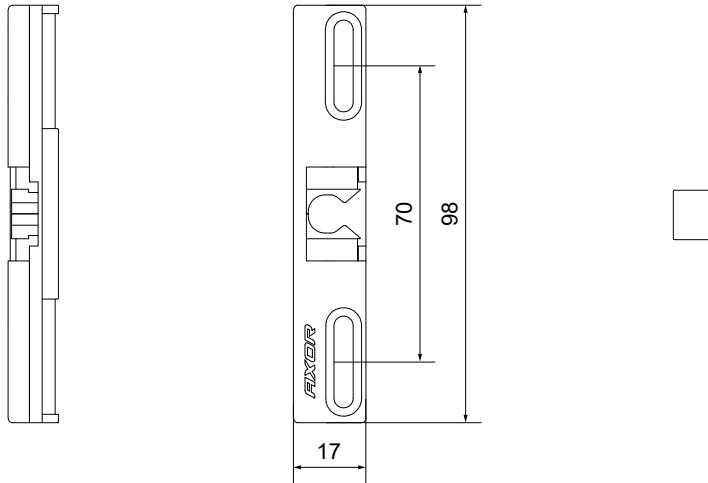

■ **Balcony catch**

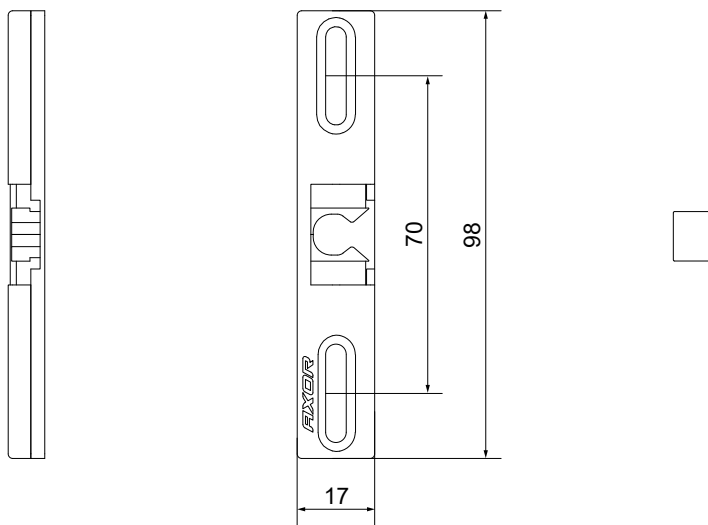

■ **Balcony catch for double-sash gear**



Description	A	C	B			Part No.
Balcony catch	12	20	13	2/4x35	100	A7046-13-N03
Balcony catch	12	20	9	2/4x35	100	A7018-09-N03
Balcony locking pin	—	—	—	1/4x30	100	A7031-00-N00
Balcony catch for double-sash gear	—	—	—	2/4x30	100	A7047-00-N03

A - Sash rebate gap / C - Sash overlap / B - Sash groove position



Section 5 ▶ Additional elements

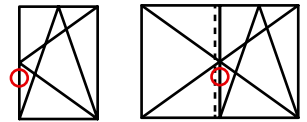

■ **Magnetic balcony catch**

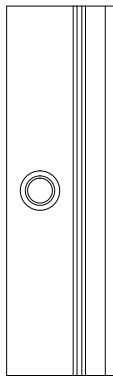
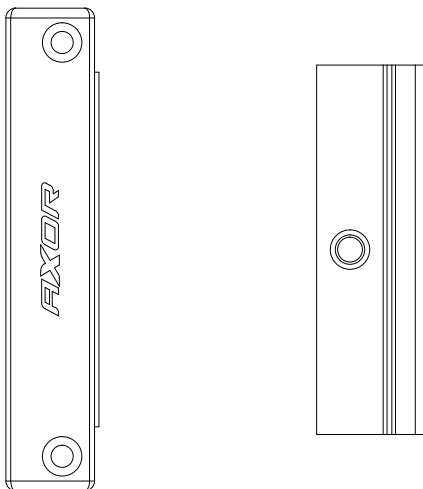
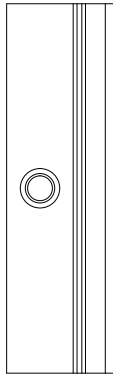
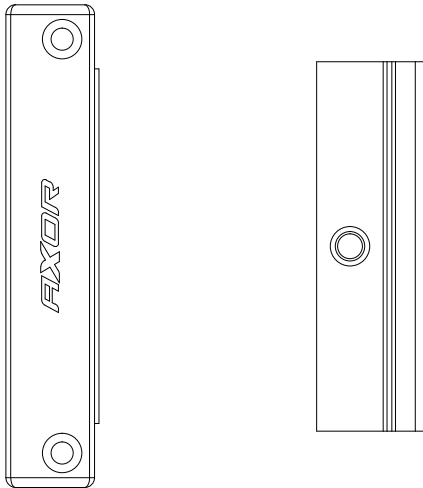

Description	A	C	B			Part No.
Magnetic balcony catch, frame part	12	20	—	2/4x35	100	A7053-00-N03
Magnetic balcony catch, sash part	—	—	13	1/4x30	100	A7055-13-N03
Magnetic balcony catch, sash part	—	—	9	1/4x30	100	A7055-09-N03
Magnetic balcony catch, double-sash gear	—	—	—	2/4x30	100	A7054-00-N03

A - Sash rebate gap / C - Sash overlap / B - Sash groove position



Section 5 ▶ Additional elements

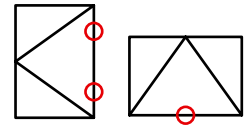

■ **Concealed middle hinge, frame part**

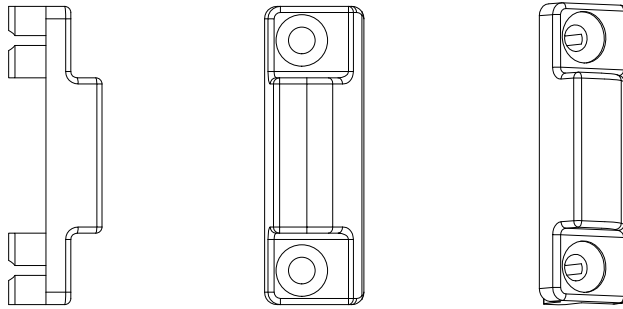

■ **Concealed middle hinge, sash part**

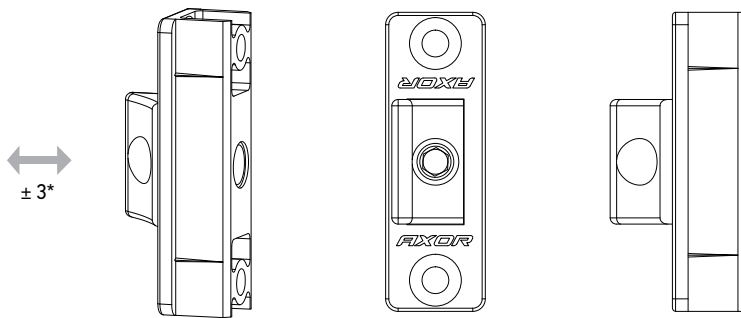

* horizontal adjustment, mm

Description	A	C	B			Part No.
Concealed middle hinge, frame part 12/20-13	12	20	13	2 / 3,9x35	100	A7057-13-N03
Concealed middle hinge, frame part 12/20-9	12	20	9	2 / 3,9x35	100	A7057-09-N03
Concealed middle hinge, sash part	—	—	—	2 / 3,9x30	100	A7056-00-N03

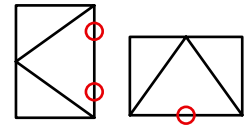

A - Sash rebate gap / C - Sash overlap / B - Sash groove position

Section 5 ▶ Additional elements

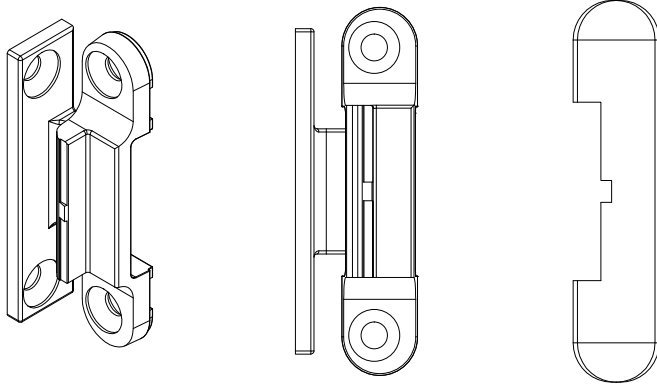

■ **Middle hinge with cover**



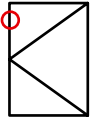

Description			Part No.
Middle hinge with cover (white)	4 / 4x25	100	A7045-00-N01
Middle hinge with cover (brown)	4 / 4x25	100	A7045-00-N02

Section 5 ▶ Additional elements

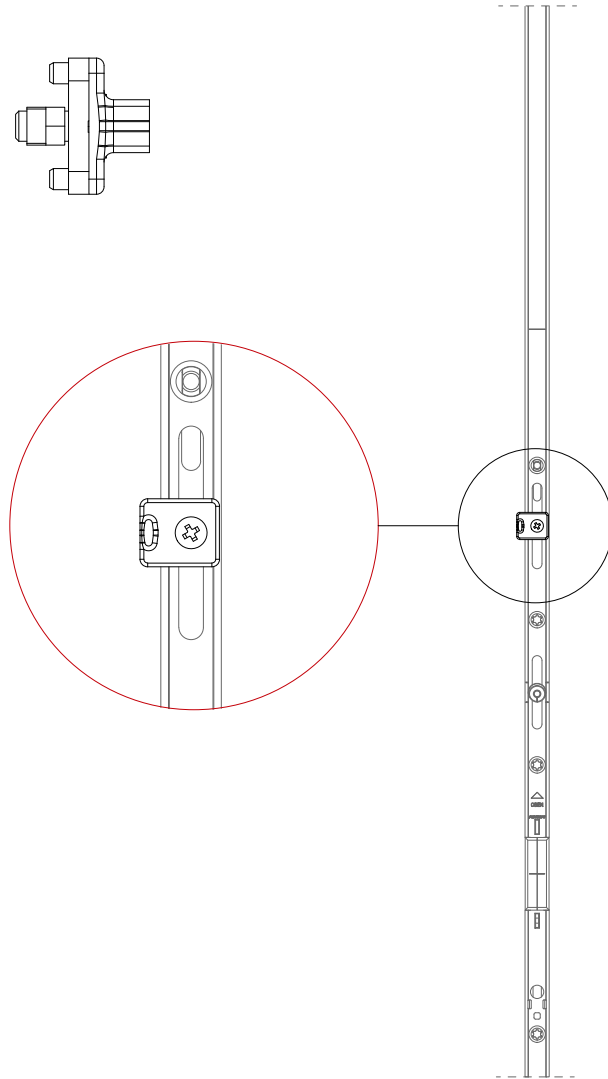
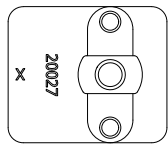
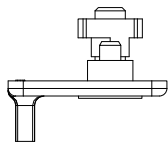
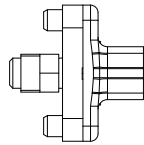
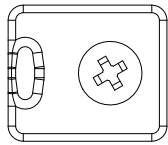

Optional micro ventilation for gear



Description	Applying		Part No.
Optional micro ventilation for gear	S1001-11-N03 S1001-15-N03 S1001-16-N03 S1001-21-N03 S1003-12-N03 S1003-15-N03 S1003-17-N03 S1003-18-N03 S1003-20-N03 S1003-22-N03	500	S7001-00-N03



Section 5 ▶ Additional elements

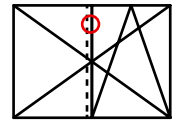

■ **Locking plate for adjustable integrated slit for double sash**

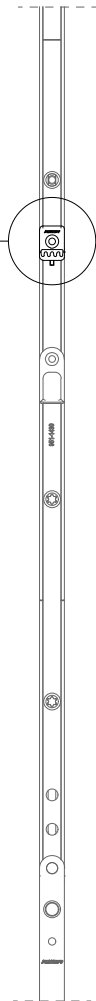
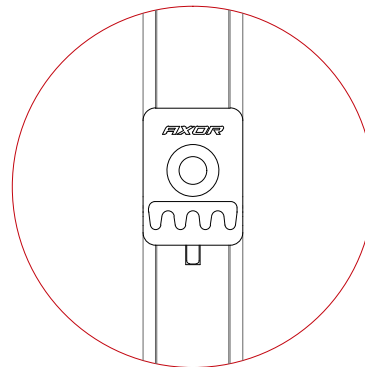
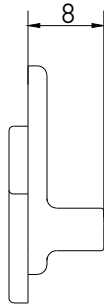
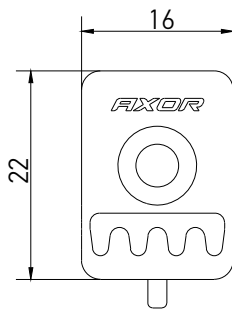

Description		Part No.
Locking plate for adjustable integrated slit for double sash	500	S6009-00-N03
Locking plate for adjustable integrated slit for double sash, frame part	250	A6004-00-N03

Section 5 ▶ Additional elements

■ **Connection piece**

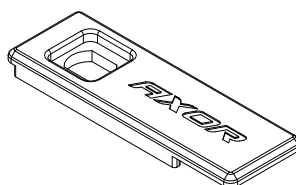
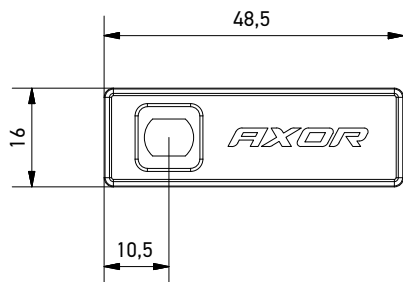

Description		Part No.
Connection piece	500	S7002-00-N03

Section 5 ▶ Additional elements

■ **Protective plate for gear**

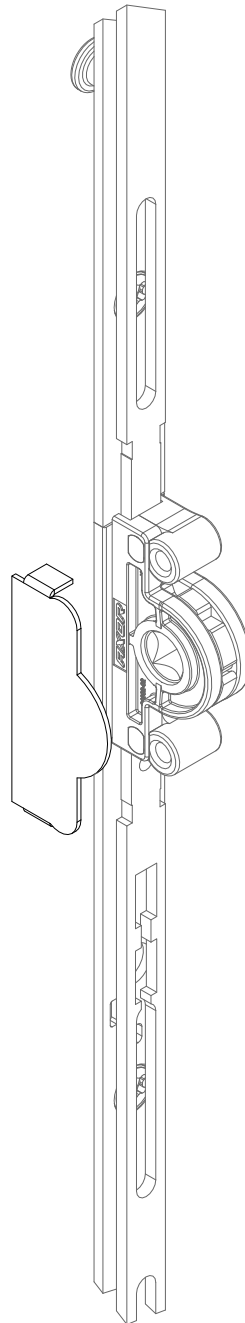
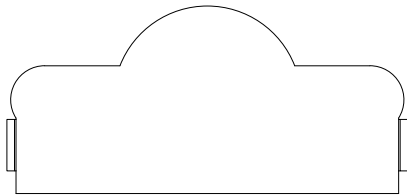

Description		Part No.
Protective plate for gear	250	A7061-00-N03

SMART LINE **S+**

[6]

Hardware set combinations



Section 6 ▶ Hardware set combinations

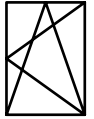

■ **System S+.**

Tilt and turn set. Basic security

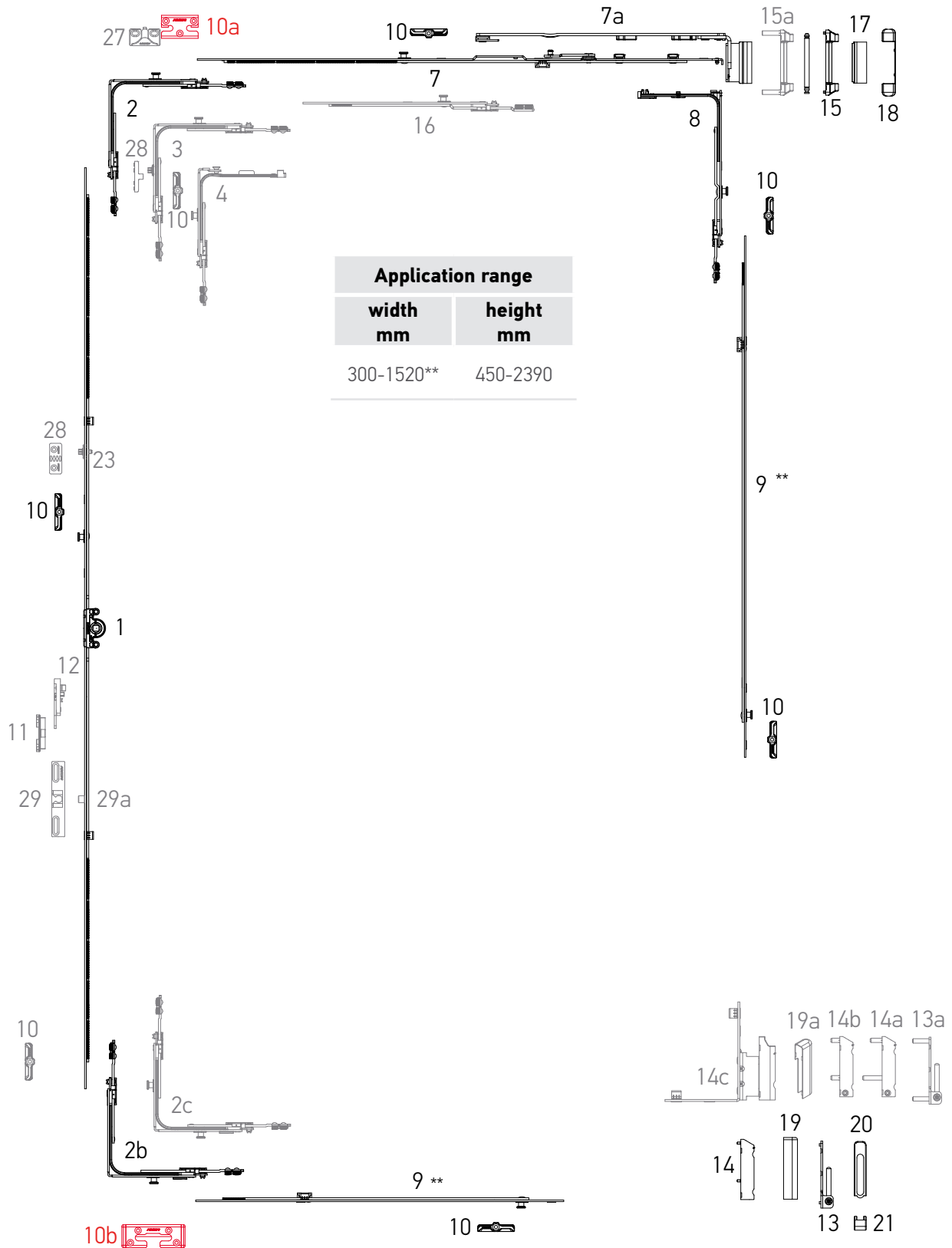

** with the linear extension 240 mm



Section 6 ▶ Hardware set combinations

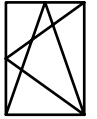

■ System S+. Tilt and turn set. Security level 1

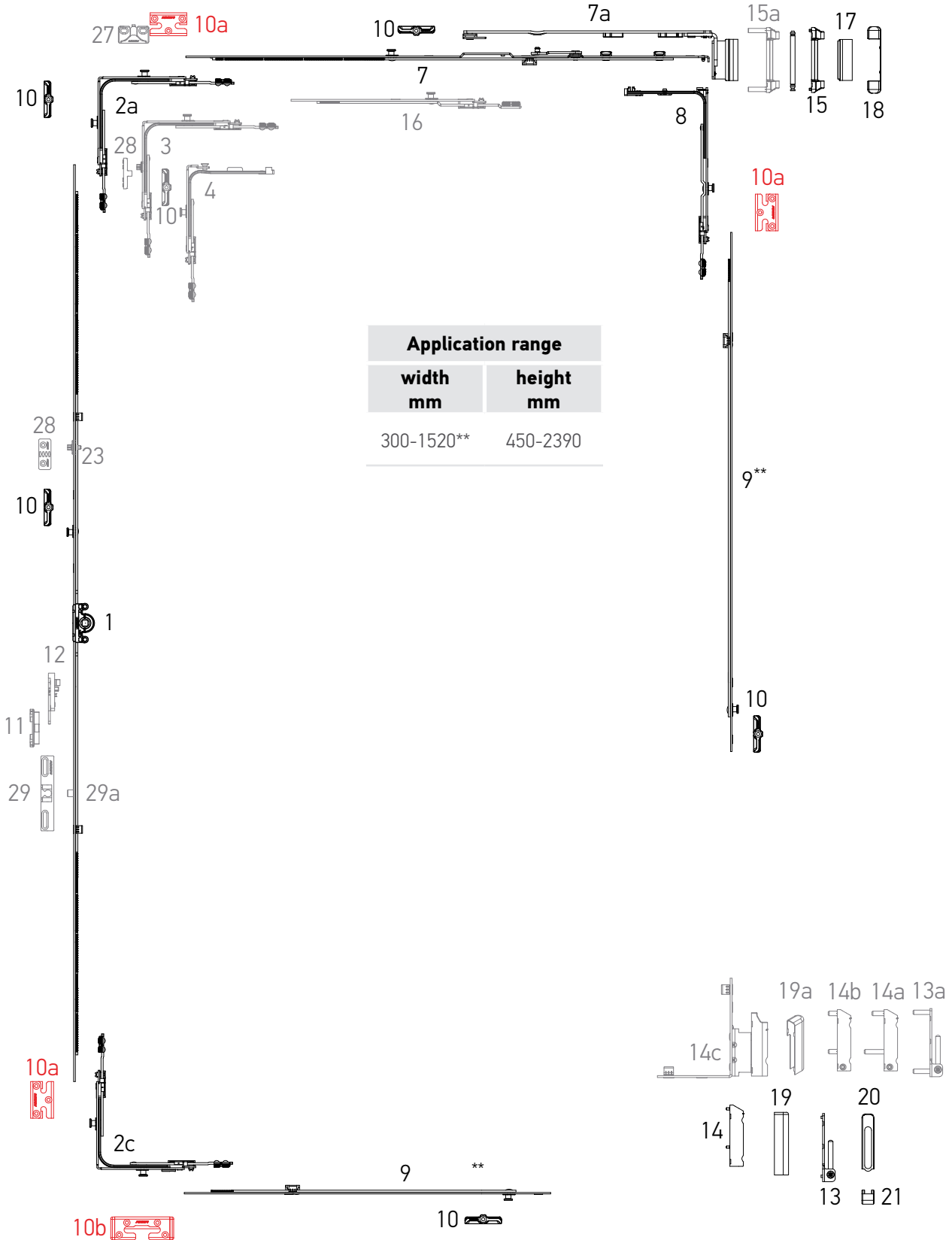

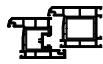

Section 6 ▶ Hardware set combinations

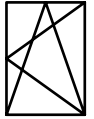

■ **System S+.**
Tilt and turn set. **Security level 2**

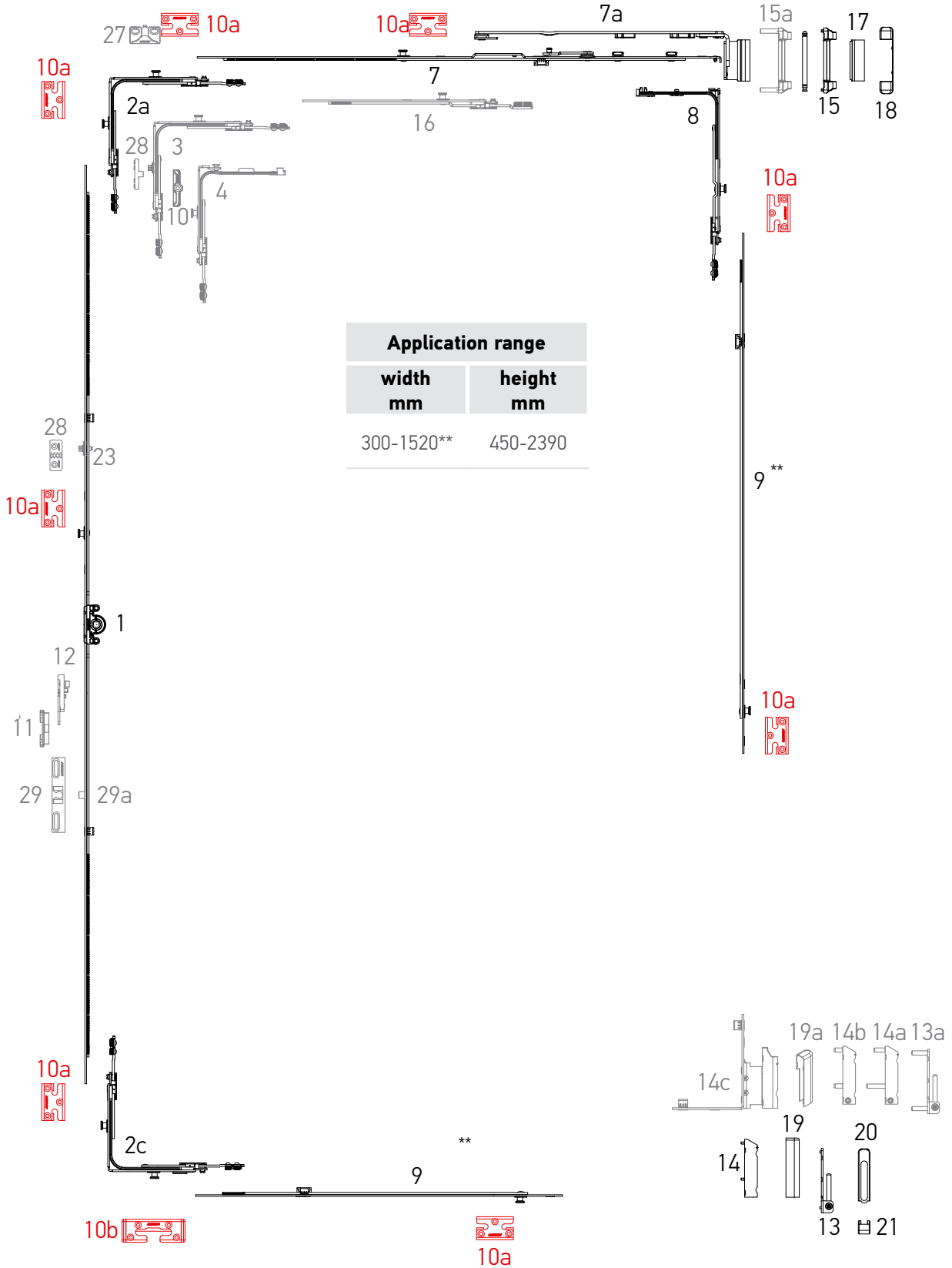

** with the linear extension 240 mm

Section 6 ▶ Hardware set combinations

**■ System S+.
Tilt and turn set**

Nº	Description	Application range by width	Application range by height	Part No.
1	Gear variable 0, L=320, 450-550	–	450-550	S1001-02-N03
	Gear variable 1, L=520, 551-750	–	551-750	S1001-04-N03
	Gear variable 2, L=1000, 751-1230, 1 ML	–	751-1230	S1001-09-N03
	Gear variable 3, L=1200, 950-1430, 1 ML	–	950-1430	S1001-11-N03
	Gear variable 4, L=1480, 1231-1710, 2 ML	–	1231-1710	S1001-15-N03
	Gear variable 5, L=1680, 1431-1910, 2 ML	–	1431-1910	S1001-16-N03
	Gear variable 6, L=2160, 1911-2390, 3 ML	–	1911-2390	S1001-21-N03
2	Corner transmission standard	400-1280	450-2390	S2001-00-N03
2a	Corner transmission, 2ML	400-1280	450-2390	S2002-00-N03
2b	Corner transmission, bottom	400-1280	450-2390	S2006-00-N03
2c	Corner transmission, 2ML, bottom	400-1280	450-2390	S2007-00-N03
3	Corner transmission, integrated slit, left	400-1280	450-2390	S2004-00-L03
	Corner transmission, integrated slit, right	400-1280	450-2390	S2004-00-R03
4	Corner transmission s	280-1280	450-2390	S2003-00-N03
		330-520	290-350	
7	Stay arm connecting plate 1 L=485, 400-600	400-600	–	S3003-05-N03
	Stay arm connecting plate 2 L=685, 601-800	601-800	–	S3003-07-N03
	Stay arm connecting plate 3 L=925, 801-1040	801-1040	–	S3003-09-N03
	Stay arm connecting plate 4 L=1165, 1041-1280	1041-1280	–	S3003-12-N03
7a	Stay arm 13, L=248, 400-600, left	400-600	–	S3001-02-L03
	Stay arm 13, L=248, 400-600, right	400-600	–	S3001-02-R03
	Stay arm 13, L = 319, 601-800, left	601-800	–	S3001-03-L03
	Stay arm 13, L = 319, 601-800, right	601-800	–	S3001-03-R03
	Stay arm 13, L = 449, 801-1040, left	801-1040	–	S3001-04-L03
	Stay arm 13, L = 449, 801-1040, right	801-1040	–	S3001-04-R03
	Stay arm 13, L = 539, 1041-1280, left	1041-1280	–	S3001-05-L03
	Stay arm 13, L = 539, 1041-1280, right	1041-1280	–	S3001-05-R03
	Stay arm 9, L=248, 400-600, left	400-600	–	S3002-02-L03
	Stay arm 9, L=248, 400-600, right	400-600	–	S3002-02-R03
	Stay arm 9, L = 319, 601-800, left	601-800	–	S3002-03-L03
	Stay arm 9, L = 319, 601-800, right	601-800	–	S3002-03-R03
	Stay arm 9, L = 449, 801-1040, left	801-1040	–	S3002-04-L03
	Stay arm 9, L = 449, 801-1040, right	801-1040	–	S3002-04-R03
	Stay arm 9, L = 539, 1041-1280, left	1041-1280	–	S3002-05-L03
	Stay arm 9, L = 539, 1041-1280, right	1041-1280	–	S3002-05-R03

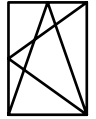
Section 6 ▶ Hardware set combinations

System S+.
Tilt and turn set

Nº	Description	Application range by width	Application range by height	Part No.
8	Middle lock vertical	-	450-850	S4001-00-N03
9	Middle lock extension L=480	800-1230	851-1230	S4002-05-N03
	Middle lock extension L=680	-	1231-1430	S4002-07-N03
	Middle lock extension L=880	1231-1620	1431-1710	S4002-09-N03
	Middle lock extension L=1040	-	1711-1910	S4002-10-N03
	Middle lock extension L=1530	-	1911-2390	S4002-15-N03
10	Locking plate	-	-	***
10a	Locking plate safety	-	-	***
10b	Tilt safety locking plate	-	-	***
11	Lifting plate	-	-	***
12	Wrong operation safety device with sash lifter	-	751-2390	A7001-00-N03
13	Corner bearing 3x3	-	-	A5002-00-N03
13a	Corner bearing 6x22	-	-	A5004-00-N03
14	Drill-in corner hinge 3x5	-	-	A5003-00-N03
14a	Drill-in corner hinge AD 6x16/26	-	-	A5006-00-N03
14b	Drill-in corner hinge with gasket pressing adjustment AD 6x12	-	-	A5007-00-N03
14c	Rebate corner hinge 20/9 left	-	-	A5009-09-L03
	Rebate corner hinge 20/9 right	-	-	A5009-09-R03
	Rebate corner hinge 20/13 left	-	-	A5009-13-L03
	Rebate corner hinge 20/13 right	-	-	A5009-13-R03
15	Stay arm bearing 3x3	-	-	A5001-00-N03
15a	Stay arm bearing 6x24	-	-	A5005-00-N03
16	Extension 240 mm	-	-	S4003-02-N03
17	Cover of top sash hinge	-	-	A7004-10-N*
18	Cover of stay arm bearing	-	-	A7005-10-N*
19	Cover of the drill-in corner hinge	-	-	A7006-10-N*
19a	Cover of rebate corner hinge, left / right	-	-	A7009-00-L/R*
20	Top cover of corner bearing	-	-	A7008-10-N*
21	Bottom cover of corner bearing	-	-	A7007-10-N*
23	Optional micro ventilation for gear	-	950-2390	S7001-00-N03
27	Locking plate, integrated slit	-	-	***
28	Locking plate for adjustable integrated slit	-	-	***
29	Balcony catch	-	-	A7046-**-N03
29a	Balcony locking pin	-	-	A7031-00-N00

* - for decorative covers in other colors look at p. 28

** according to displacement axis of sash groove (9 mm, 10 mm, 13 mm, 14 mm)

*** look at the section "Profile-dependent elements" or "Hinges group" of SMART LINE S+ technical catalogue



Section 6 ▶ Hardware set combinations

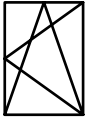

■ **System S+.**

Tilt and turn set “First tilt”

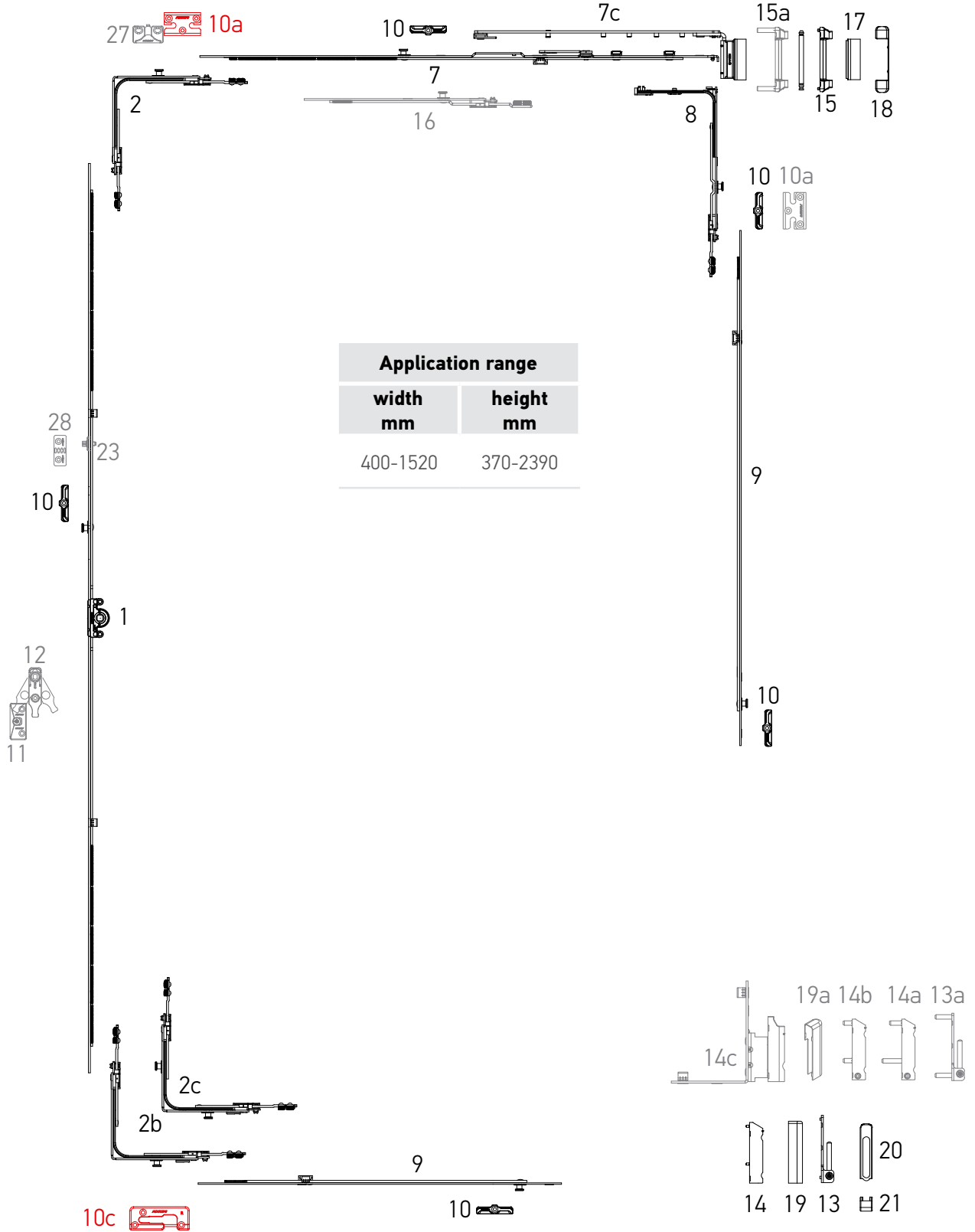



Section 6 ▶ Hardware set combinations



■ **System S+. Tilt and turn set “First tilt”**

Nº	Description	Application range by width	Application range by height	Part No.
1	Gear variable 0, L=320, 450-550	–	450-550	S1001-02-N03
	Gear variable 1, L=520, 551-750	–	551-750	S1001-04-N03
	Gear variable 2, L=1000, 751-1230, 1 ML	–	751-1230	S1001-09-N03
	Gear variable 3, L=1200, 950-1430, 1 ML	–	950-1430	S1001-11-N03
	Gear variable 4, L=1480, 1231-1710, 2 ML	–	1231-1710	S1001-15-N03
	Gear variable 5, L=1680, 1431-1910, 2 ML	–	1431-1910	S1001-16-N03
	Gear variable 6, L=2160, 1911-2390, 3 ML	–	1911-2390	S1001-21-N03
2	Corner transmission standard	400-1280	450-2390	S2001-00-N03
2b	Corner transmission 115x115, bottom	400-1280	450-2390	S2006-00-N03
2c	Corner transmission 115x115, 2ML, bottom	400-1280	450-2390	S2007-00-N03
7	Stay arm connecting plate 1 L=485, 400-600	400-600	–	S3003-05-N03
	Stay arm connecting plate 2 L=685, 601-800	601-800	–	S3003-07-N03
	Stay arm connecting plate 3 L=925, 801-1040	801-1040	–	S3003-09-N03
	Stay arm connecting plate 4 L=1165, 1041-1280	1041-1280	–	S3003-12-N03
7c	Stay arm 13, “First tilt” L = 222, 400-600, left	400-600	–	S3006-02-L03
	Stay arm 13, “First tilt” L = 222, 400-600, right	400-600	–	S3006-02-R03
	Stay arm 13, “First tilt” L = 319, 601-800, left	601-800	–	S3006-03-L03
	Stay arm 13, “First tilt” L = 319, 601-800, right	601-800	–	S3006-03-R03
	Stay arm 13, “First tilt” L = 449, 801-1040, left	801-1040	–	S3006-04-L03
	Stay arm 13, “First tilt” L = 449, 801-1040, right	801-1040	–	S3006-04-R03
	Stay arm 13, “First tilt” L=539, 1041-1280, left	1041-1280	–	S3006-05-L03
	Stay arm 13, “First tilt” L=539, 1041-1280, right	1041-1280	–	S3006-05-R03
8	Middle lock vertical	–	450-850	S4001-00-N03
9	Middle lock extension L=480	800-1230	851-1230	S4002-05-N03
	Middle lock extension L=680	–	1231-1430	S4002-07-N03
	Middle lock extension L=880	1231-1620	1431-1710	S4002-09-N03
	Middle lock extension L=1040	–	1711-1910	S4002-10-N03
	Middle lock extension L=1530	–	1911-2390	S4002-15-N03
10	Locking plate	–	–	***
10a	Locking plate safety	–	–	***
10c	Tilt safety locking plate “First tilt”	–	–	***
11	Lifting plate	–	–	***
12	Wrong operation safety device with sash lifter	–	751-2390	A7001-00-N03
13	Corner bearing 3x3	–	–	A5002-00-N03
13a	Corner bearing 6x22	–	–	A5004-00-N03

Section 6 ▶ Hardware set combinations
■ System S+. Tilt and turn set “First tilt”

Nº	Description	Application range by width	Application range by height	Part No.
14	Drill-in corner hinge 3x5	–	–	A5003-00-N03
14a	Drill-in corner hinge AD 6x16/26	–	–	A5006-00-N03
14b	Drill-in corner hinge with gasket pressing adjustment AD 6x12	–	–	A5007-00-N03
14c	Rebate corner hinge 20/9 left	–	–	A5009-09-L03
	Rebate corner hinge 20/9 right	–	–	A5009-09-R03
	Rebate corner hinge 20/13 left	–	–	A5009-13-L03
	Rebate corner hinge 20/13 right	–	–	A5009-13-R03
15	Stay arm bearing 3x3	–	–	A5001-00-N03
15a	Stay arm bearing 6x24	–	–	A5005-00-N03
16	Extension 240 mm	–	–	S4003-02-N03
17	Cover of top sash hinge	–	–	A7004-10-N**
18	Cover of stay arm bearing	–	–	A7005-10-N**
19	Cover of the drill-in corner hinge	–	–	A7006-10-N**
19a	Cover of rebate corner hinge, left / right	–	–	A7009-00-L/R**
20	Top cover of corner bearing	–	–	A7008-10-N**
21	Bottom cover of corner bearing	–	–	A7007-10-N**
23	Optional micro ventilation for gear	–	950-2390	S7001-00-N03
27	Locking plate	–	–	***
28	Locking plate for integrated slit	–	–	***

** - for decorative covers in other colors look at p. 28

*** look at the section “Profile-dependent elements” or “Hinges group” of SMART LINE S+ technical catalogue



Section 6 ▶ Hardware set combinations

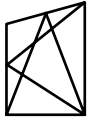

■ **System S+. Tilt and turn set for oblique window**

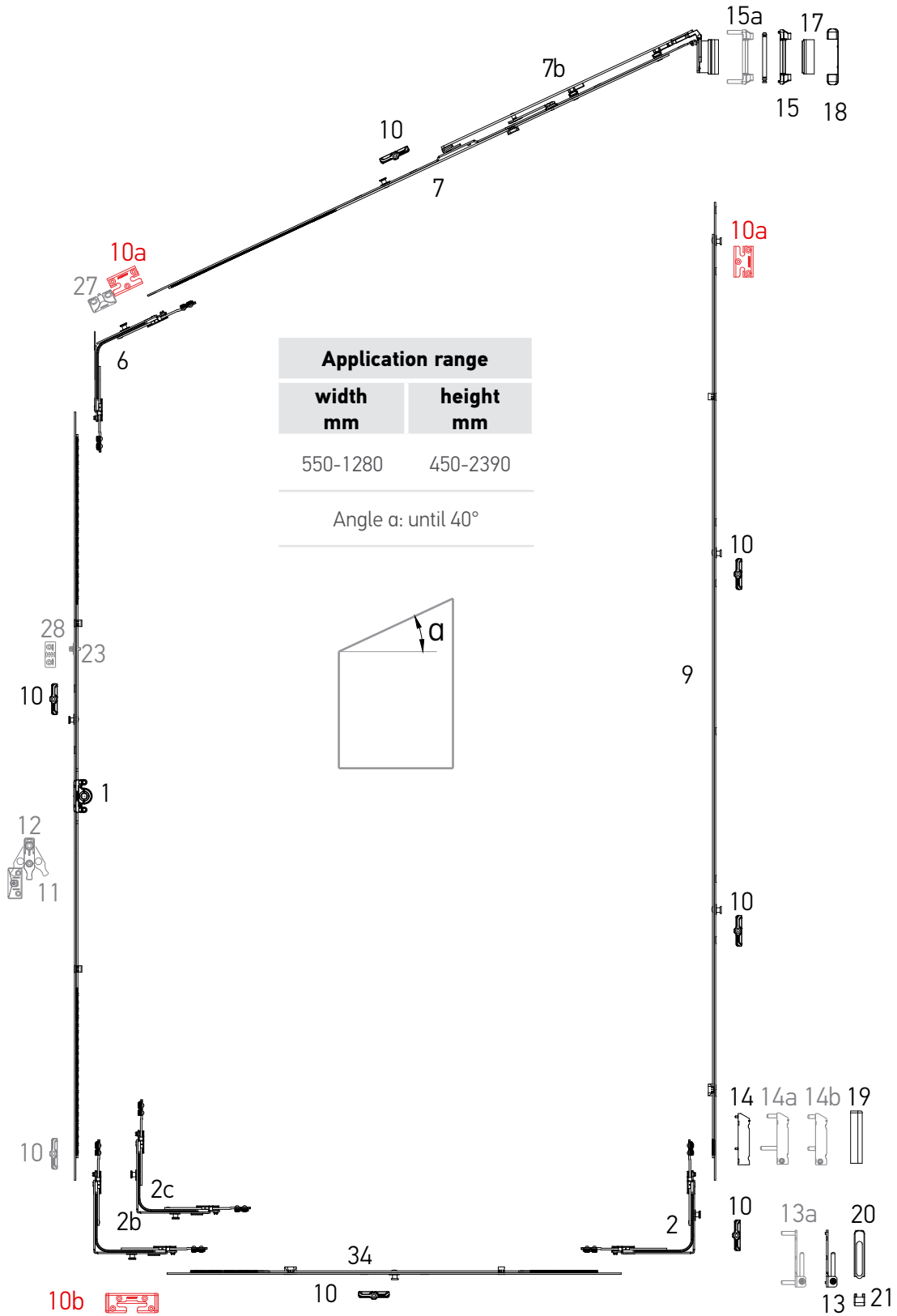

Section 6 ▶ Hardware set combinations

■ System S+. Tilt and turn set for oblique window

N°	Description	Application range by width	Application range by height	Part No.
1	Gear variable 0, L=320, 450-550	–	450-550	S1001-02-N03
	Gear variable 1, L=520, 551-750	–	551-750	S1001-04-N03
	Gear variable 2, L=1000, 751-1230, 1 ML	–	751-1230	S1001-09-N03
	Gear variable 3, L=1200, 950-1430, 1 ML	–	950-1430	S1001-11-N03
	Gear variable 4, L=1480, 1231-1710, 2 ML	–	1231-1710	S1001-15-N03
	Gear variable 5, L=1680, 1431-1910, 2 ML	–	1431-1910	S1001-16-N03
	Gear variable 6, L=2160, 1911-2390, 3 ML	–	1911-2390	S1001-21-N03
2	Corner transmission 115x115	400-1280	450-2390	S2001-00-N03
2b	Corner transmission 115x115, bottom	400-1280	450-2390	S2006-00-N03
2c	Corner transmission 115x115, 2ML, bottom	400-1280	450-2390	S2007-00-N03
6	Corner transmission 115x115, 1 ML, for oblique window - S+	400-1280	450-2390	S2008-00-N03
7	Stay arm connecting plate 1 L=485, 400-600	400-600	–	S3003-05-N03
	Stay arm connecting plate 2 L=685, 601-800	601-800	–	S3003-07-N03
	Stay arm connecting plate 3 L=925, 801-1040	801-1040	–	S3003-09-N03
	Stay arm connecting plate 4 L=1165, 1041-1280	1041-1280	–	S3003-12-N03
7b	Stay arm for oblique window 13, L=248, 400-600, left - S+	400-600	–	S3004-02-L03
	Stay arm for oblique window 13, L=248, 400-600, right - S+	400-600	–	S3004-02-R03
	Stay arm for oblique window 13, L=319, 601-800, left - S+	601-800	–	S3004-03-L03
	Stay arm for oblique window 13, L=319, 601-800, right - S+	601-800	–	S3004-03-R03
	Stay arm for oblique window 13, L = 449, 801-1040, left - S+	801-1040	–	S3004-04-L03
	Stay arm for oblique window 13, L = 449, 801-1040, right - S+	801-1040	–	S3004-04-R03
	Stay arm for oblique window 13, L = 539, 1041-1280, left - S+	1041-1280	–	S3004-05-L03
	Stay arm for oblique window 13, L = 539, 1041-1280, right - S+	1041-1280	–	S3004-05-R03
	Stay arm for oblique window 9, L=248, 400-600, left - S+	400-600	–	S3005-02-L03
	Stay arm for oblique window 9, L=248, 400-600, right - S+	400-600	–	S3005-02-R03
	Stay arm for oblique window 9, L=319, 601-800, left - S+	601-800	–	S3005-03-L03
	Stay arm for oblique window 9, L=319, 601-800, right - S+	601-800	–	S3005-03-R03
	Stay arm for oblique window 9, L = 449, 801-1040, left - S+	801-1040	–	S3005-04-L03

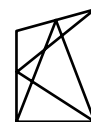
Section 6 ▶ Hardware set combinations

■ System S+. Tilt and turn set for oblique window

Nº	Description	Application range by width	Application range by height	Part No.
7b	Stay arm for oblique window 9, L = 449, 801-1040, right - S+	801-1040	–	S3005-04-R03
	Stay arm for oblique window 9, L = 539, 1041-1280, left - S+	1041-1280	–	S3005-05-L03
	Stay arm for oblique window 9, L = 539, 1041-1280, right - S+	1041-1280	–	S3005-05-R03
9	Middle lock extension L=480	–	850-1230	S4002-05-N03
	Middle lock extension L=680	–	1231-1430	S4002-07-N03
	Middle lock extension L=880	–	1431-1710	S4002-09-N03
	Middle lock extension L=1040	–	1711-1910	S4002-10-N03
	Middle lock extension L=1530	–	1911-2390	S4002-15-N03
10	Locking plate	–	–	***
10a	Locking plate safety	–	–	***
10b	Tilt safety locking plate	–	–	***
11	Lifting plate	–	–	***
12	Wrong operation safety device with sash lifter	–	751-2390	A7001-00-N03
13	Corner bearing 3x3	–	–	A5002-00-N03
13a	Corner bearing 6x22	–	–	A5004-00-N03
14	Drill-in corner hinge 3x5	–	–	A5003-00-N03
14a	Drill-in corner hinge AD 6x16/26	–	–	A5006-00-N03
14b	Drill-in corner hinge with gasket pressing adjustment 6x12	–	–	A5007-00-N03
15	Stay arm bearing 3x3	–	–	A5001-00-N03
15a	Stay arm bearing 6x24	–	–	A5005-00-N03
17	Cover of top sash hinge	–	–	A7004-10-N**
18	Cover of stay arm bearing	–	–	A7005-10-N**
19	Cover of the drill-in corner hinge	–	–	A7006-10-N**
20	Top cover of corner bearing	–	–	A7008-10-N**
21	Bottom cover of corner bearing	–	–	A7007-10-N**
23	Optional micro ventilation for gear	–	950-2390	S7001-00-N03
27	Locking plate, integrated slit	–	–	***
28	Locking plate for adjustable integrated slit	–	–	***
34	Middle connection L = 520, 551-750	551-750	–	S4005-05-N03
	Middle connection L = 720, 751-950	751-950	–	S4005-07-N03
	Middle connection L = 1200, 951-1430	951-1430	–	S4005-12-N03

** - for decorative covers in other colors look at p. 28

*** look at the section "Profile-dependent elements" or "Hinges group" of SMART LINE S+ technical catalogue



Section 6 ▶ Hardware set combinations

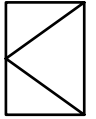

■ System S+. Turn set. Basic security

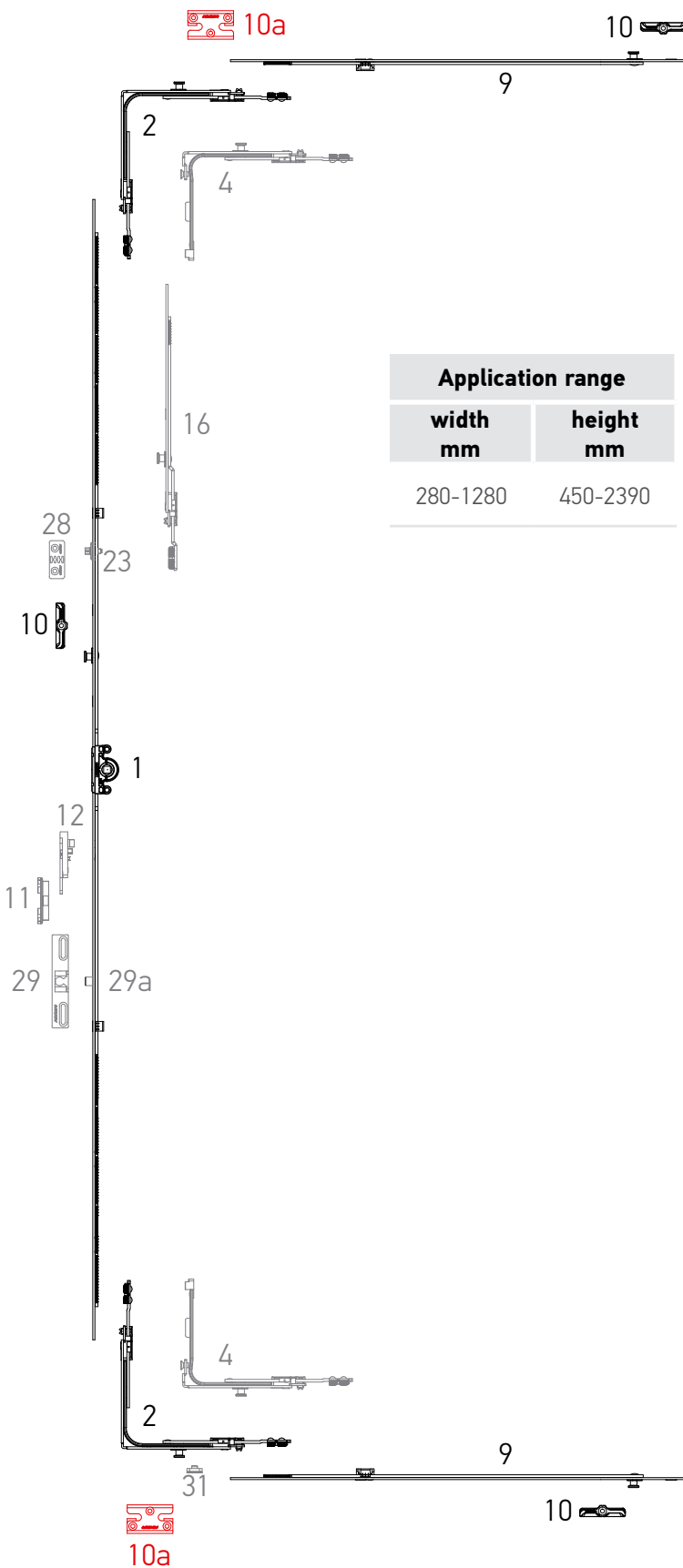

Application range	
width mm	height mm
280-1280	450-2390

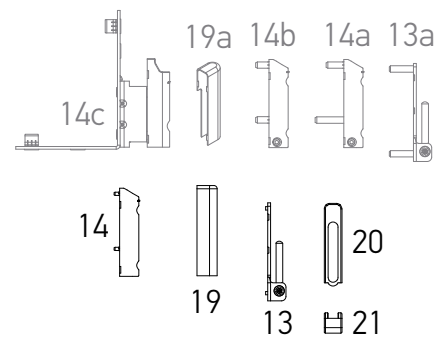
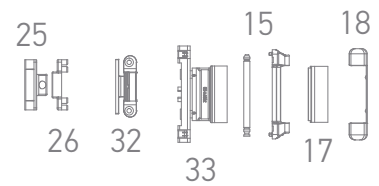
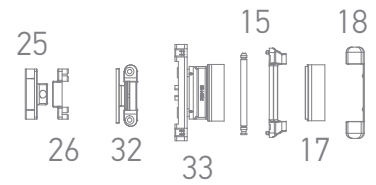
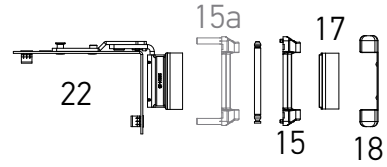



Section 6 ▶ Hardware set combinations

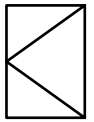

System S+.
Turn set. Security level 1

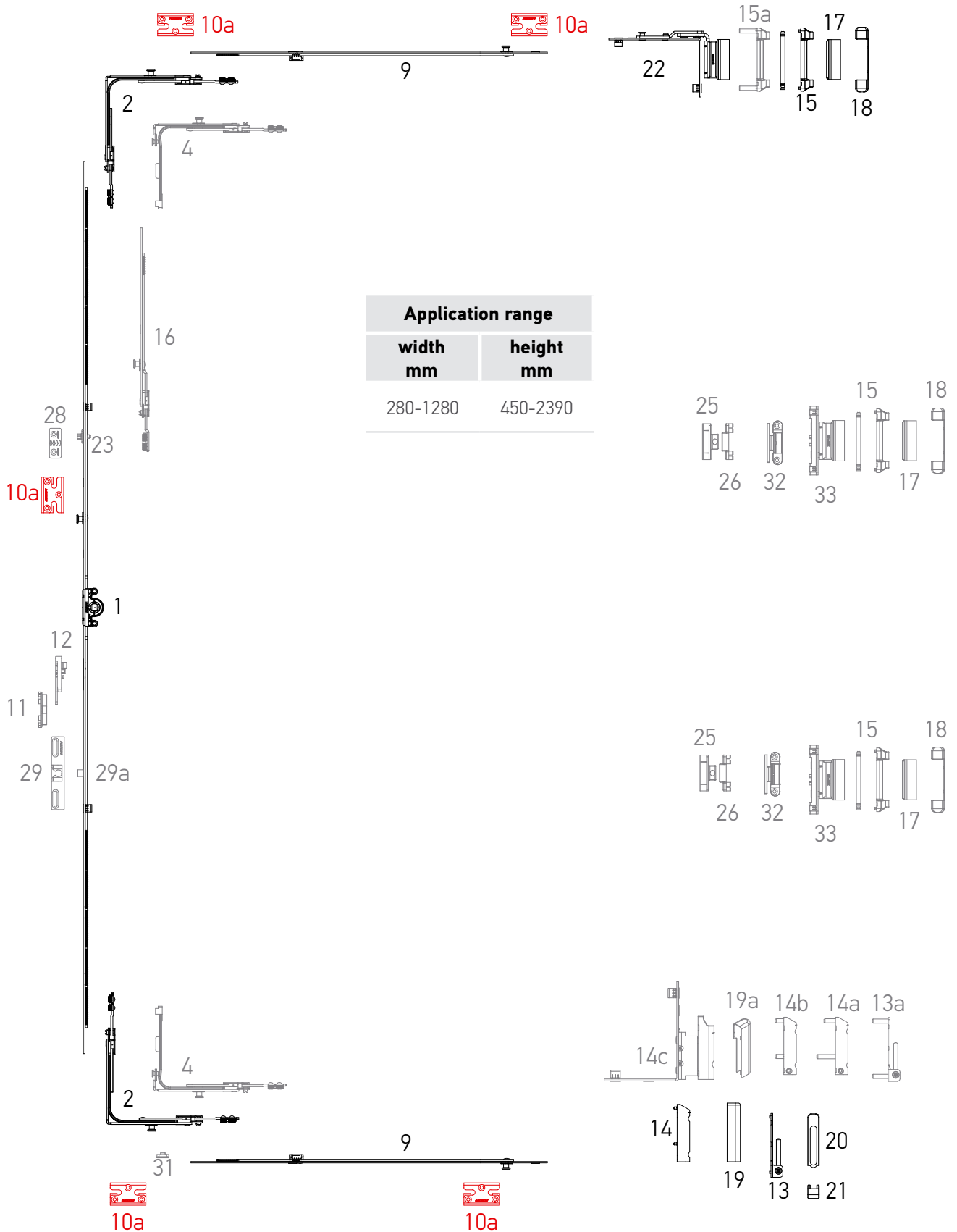

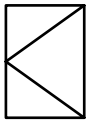
Section 6 ▶ Hardware set combinations

■ System S+. Turn set

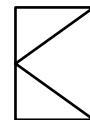
Nº	Description	Application range by width	Application range by height	Part No.
1	Gear variable 0, L=320, 450-550	–	450-550	S1001-02-N03
	Gear variable 1, L=520, 551-750	–	551-750	S1001-04-N03
	Gear variable 2, L=1000, 751-1230, 1 ML	–	751-1230	S1001-09-N03
	Gear variable 3, L=1200, 950-1430, 1 ML	–	950-1430	S1001-11-N03
	Gear variable 4, L=1480, 1231-1710, 2 ML	–	1231-1710	S1001-15-N03
	Gear variable 5, L=1680, 1431-1910, 2 ML	–	1431-1910	S1001-16-N03
	Gear variable 6, L=2160, 1911-2390, 3 ML	–	1911-2390	S1001-21-N03
2	Corner transmission standard	400-1280	450-2390	S2001-00-N03
2a	Corner transmission, 2ML	400-1280	450-2390	S2002-00-N03
4	Corner transmission s	280-1280	450-2390	S2003-00-N03
		330-520	290-350	
9	Middle lock extension L=480	800-1230	–	S4002-05-N03
	Middle lock extension L=880	1231-1620	–	S4002-09-N03
10	Locking plate	–	–	***
10a	Locking plate safety	–	–	***
11	Lifting plate	–	–	***
12	Wrong operation safety device with sash lifter	–	751-2390	A7001-00-N03
13	Corner bearing 3x3	–	–	A5002-00-N03
13a	Corner bearing 6x22	–	–	A5004-00-N03
14	Drill-in corner hinge 3x5	–	–	A5003-00-N03
14a	Drill-in corner hinge AD 6x16/26	–	–	A5006-00-N03
14b	Drill-in corner hinge with gasket pressing adjustment AD 6x12	–	–	A5007-00-N03
14c	Rebate corner hinge 20/9 left	–	–	A5009-09-L03
	Rebate corner hinge 20/9 right	–	–	A5009-09-R03
	Rebate corner hinge 20/13 left	–	–	A5009-13-L03
	Rebate corner hinge 20/13 right	–	–	A5009-13-R03
15	Stay arm bearing 3x3	–	–	A5001-00-N03
15a	Stay arm bearing 6x24	–	–	A5005-00-N03
16	Extension 240 mm	–	–	S4003-02-N03
17	Cover of top sash hinge	–	–	A7004-10-N*
18	Cover of stay arm bearing	–	–	A7005-10-N*
19	Cover of the drill-in corner hinge	–	–	A7006-10-N*
19a	Cover of rebate corner hinge, left / right	–	–	A7009-00-L/R**
20	Top cover of corner bearing	–	–	A7008-10-N*
21	Bottom cover of corner bearing	–	–	A7007-10-N*

Section 6 ▶ Hardware set combinations

■ System S+. Turn set

N°	Description	Application range by width	Application range by height	Part No.
22	Turn stay arm 12/20-13 left	280-1200	–	S5001-13-L03
	Turn stay arm 12/20-13 right	280-1200	–	S5001-13-R03
	Turn stay arm 12/20-9 left	280-1200	–	S5001-09-L03
	Turn stay arm 12/20-9 right	280-1200	–	S5001-09-R03
23	Optional micro ventilation for gear	–	950-2390	S7001-00-N03
25	Concealed middle hinge sash part	–	–	A7056-00-N03
26	Concealed middle hinge frame part	–	–	A7057-**-N03
29	Balcony catch	–	–	A7046-**-N03
29a	Balcony locking pin	–	–	A7031-00-N00
31	Stroke limiter 90°	–	–	A7052-00-N03
32	Middle hinge with cover	–	–	A7045-00-N03
33	Middle hinge	–	–	A7030-**-N01

* - for decorative covers in other colors look at p. 28

** according to displacement axis of sash groove (9 mm, 10 mm, 13 mm, 14 mm)

*** look at the section "Profile-dependent elements" or "Hinges group" of SMART LINE S+ technical catalogue



Section 6 ▶ Hardware set combinations

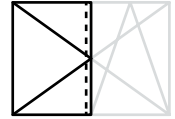

■ **System S+.**

Double sash. Secondary sash of double-sash window. Basic security

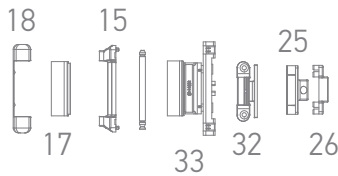
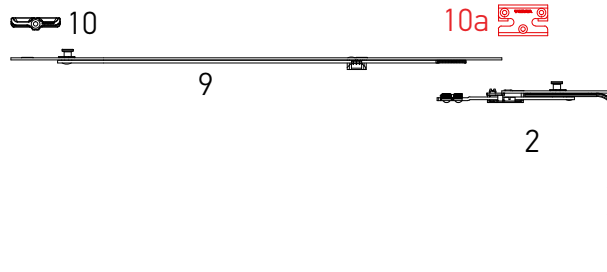
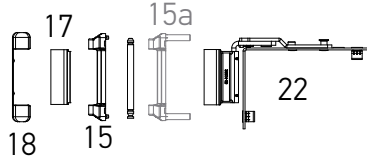

Application range	
width mm	height mm
400-1280	550-2390

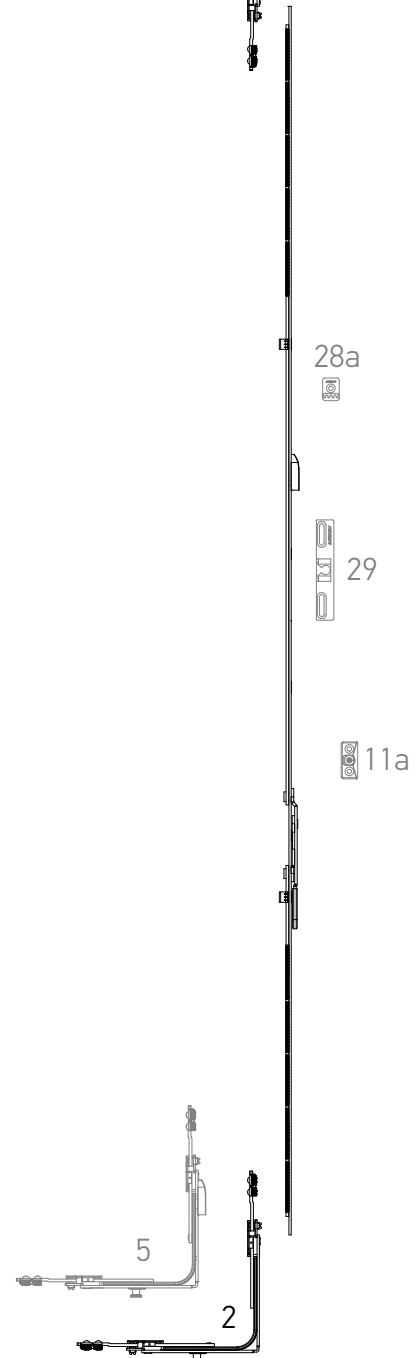
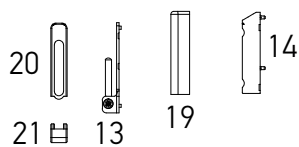
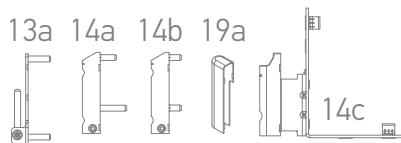
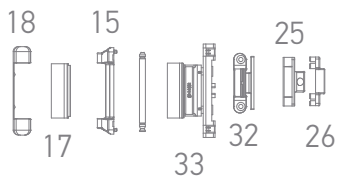



Section 6 ▶ Hardware set combinations

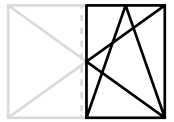

■ **System S+.**
Double sash. Main sash. Basic security

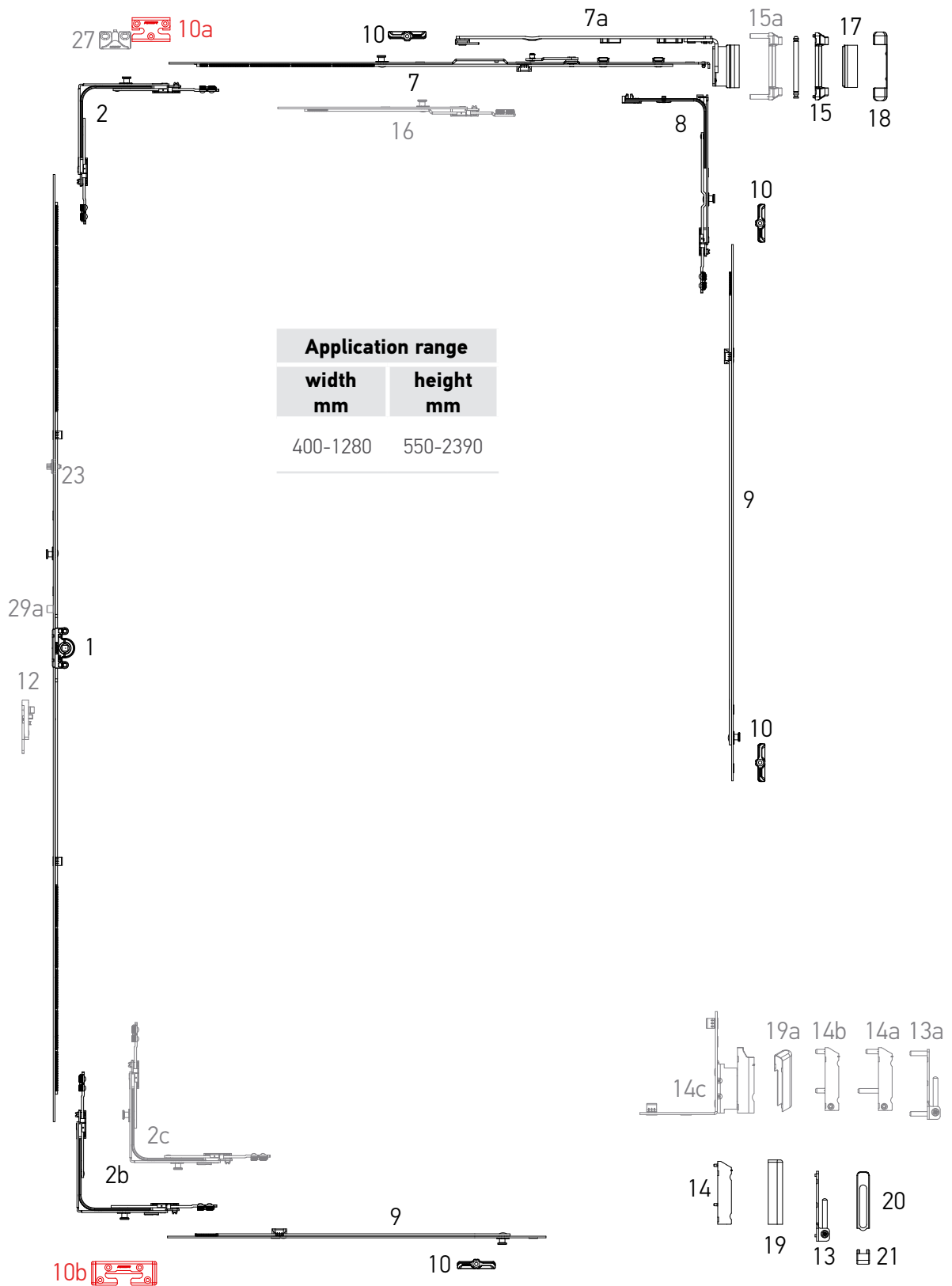



Section 6 ▶ Hardware set combinations

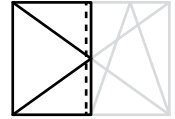

■ **System S+.**

Double sash. Secondary sash of double-sash window. Security level 1

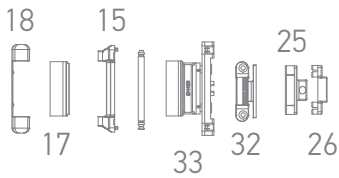
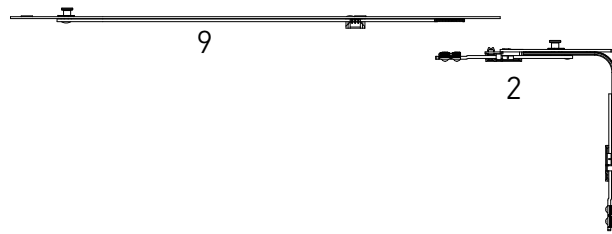
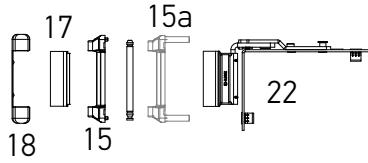

Application range	
width mm	height mm
400-1280	550-2390

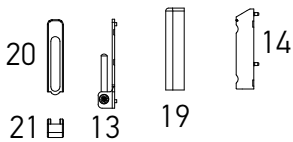
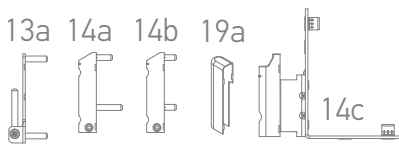
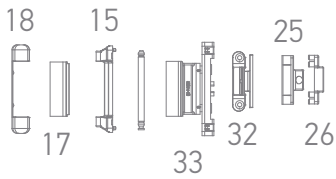



Section 6 ▶ Hardware set combinations

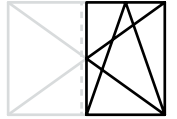

■ **System S+.**
Double sash. Main sash. Security level 1

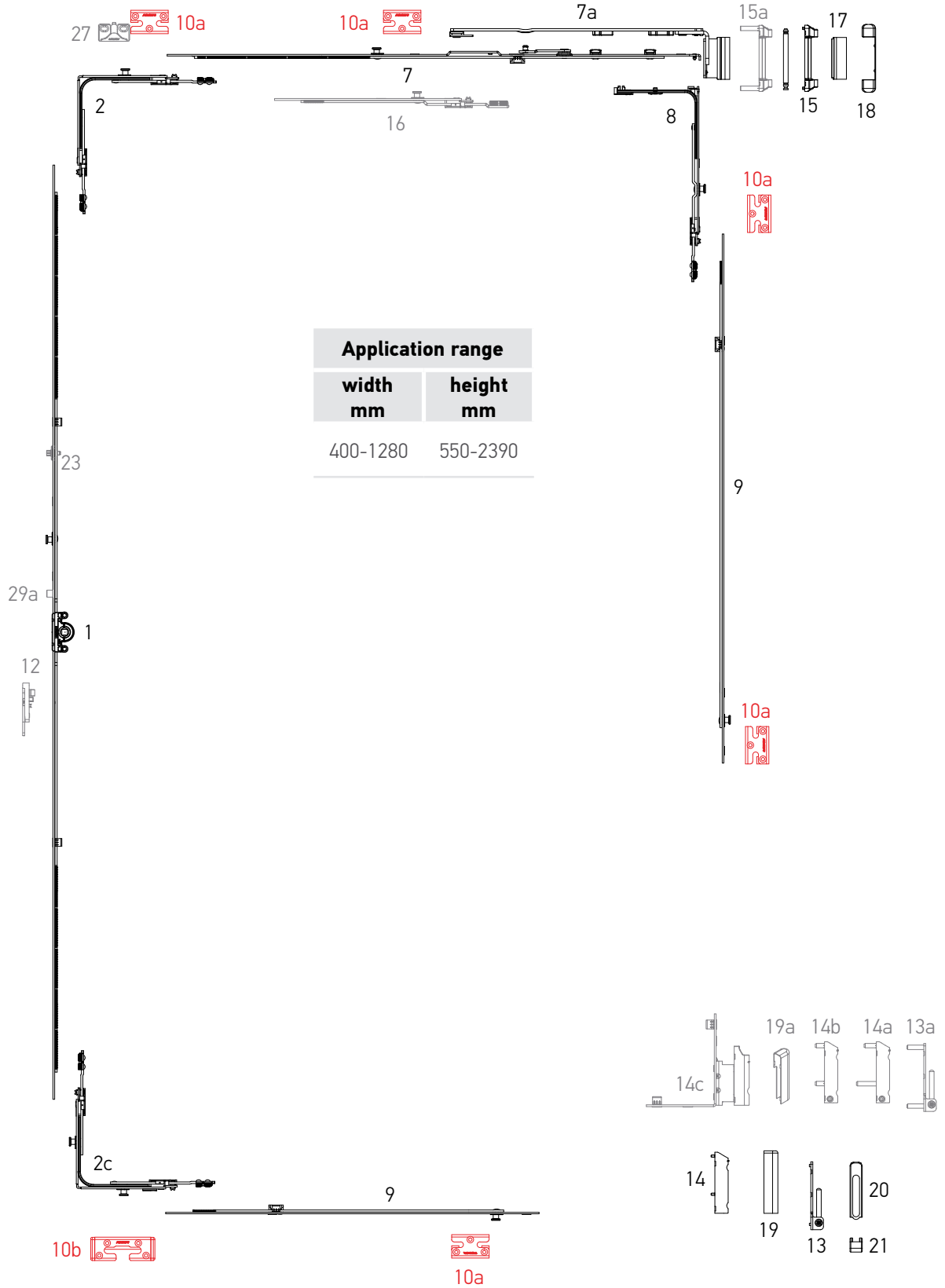

Section 6 ▶ Hardware set combinations

■ System S+. Double sash

Nº	Description	Application range by width	Application range by height	Part No.
1	Gear variable 1, L=520, 551-750	–	551-750	S1001-04-N03
	Gear variable 2, L=1000, 751-1230, 1 ML	–	751-1230	S1001-09-N03
	Gear variable 3, L=1200, 950-1430, 1 ML	–	950-1430	S1001-11-N03
	Gear variable 5, L=1680, 1431-1910, 2 ML	–	1431-1910	S1001-16-N03
	Gear variable 6, L=2160, 1911-2390, 3 ML	–	1911-2390	S1001-21-N03
2	Corner transmission standard	400-1280	450-2390	S2001-00-N03
2b	Corner transmission, bottom	400-1280	450-2390	S2006-00-N03
2c	Corner transmission, 2ML, bottom	400-1280	450-2390	S2007-00-N03
5	Corner transmission, double sash	400-1280	550-2390	S2005-00-N03
7	Stay arm connecting plate 1 L=485, 400-600	400-600	–	S3003-05-N03
	Stay arm connecting plate 2 L=685, 601-800	601-800	–	S3003-07-N03
	Stay arm connecting plate 3 L=925, 801-1040	801-1040	–	S3003-09-N03
	Stay arm connecting plate 4 L=1165, 1041-1280	1041-1280	–	S3003-12-N03
7a	Stay arm 13, L=248, 400-600, left	400-600	–	S3001-02-L03
	Stay arm 13, L=248, 400-600, right	400-600	–	S3001-02-R03
	Stay arm 13, L = 319, 601-800, left	601-800	–	S3001-03-L03
	Stay arm 13, L = 319, 601-800, right	601-800	–	S3001-03-R03
	Stay arm 13, L = 449, 801-1040, left	801-1040	–	S3001-04-L03
	Stay arm 13, L = 449, 801-1040, right	801-1040	–	S3001-04-R03
	Stay arm 13, L = 539, 1041-1280, left	1041-1280	–	S3001-05-L03
	Stay arm 13, L = 539, 1041-1280, right	1041-1280	–	S3001-05-R03
	Stay arm 9, L=248, 400-600, left	400-600	–	S3002-02-L03
	Stay arm 9, L=248, 400-600, right	400-600	–	S3002-02-R03
	Stay arm 9, L = 319, 601-800, left	601-800	–	S3002-03-L03
	Stay arm 9, L = 319, 601-800, right	601-800	–	S3002-03-R03
	Stay arm 9, L = 449, 801-1040, left	801-1040	–	S3002-04-L03
	Stay arm 9, L = 449, 801-1040, right	801-1040	–	S3002-04-R03
	Stay arm 9, L = 539, 1041-1280, left	1041-1280	–	S3002-05-L03
	Stay arm 9, L = 539, 1041-1280, right	1041-1280	–	S3002-05-R03
8	Middle lock vertical	–	551-850	S4001-00-N03
9	Middle lock extension L=480	800-1230	850-1230	S4002-05-N03
	Middle lock extension L=680	–	1231-1430	S4002-07-N03
	Middle lock extension L=880	1231-1620	1431-1710	S4002-09-N03
	Middle lock extension L=1040	–	1711-1910	S4002-10-N03
	Middle lock extension L=1530	–	1911-2390	S4002-15-N03
10	Locking plate	–	–	***
10a	Locking plate safety	–	–	***
10b	Tilt safety locking plate	–	–	***
11a	Lifting plate, double sash	–	751-2390	A6001-00-N03

Section 6 ▶ Hardware set combinations

■ System S+. Double sash

Nº	Description	Application range by width	Application range by height	Part No.
12	Wrong operation safety device with sash lifter	–	751-2390	A7001-00-N03
13	Corner bearing 3x3	–	–	A5002-00-N03
13a	Corner bearing 6x22	–	–	A5004-00-N03
14	Drill-in corner hinge 3x5	–	–	A5003-00-N03
14a	Drill-in corner hinge AD 6x16/26	–	–	A5006-00-N03
14b	Drill-in corner hinge with gasket pressing adjustment AD 6x12	–	–	A5007-00-N03
14c	Rebate corner hinge 20/9 left	–	–	A5009-09-L03
	Rebate corner hinge 20/9 right	–	–	A5009-09-R03
	Rebate corner hinge 20/13 left	–	–	A5009-13-L03
	Rebate corner hinge 20/13 right	–	–	A5009-13-R03
15	Stay arm bearing 3x3	–	–	A5001-00-N03
15a	Stay arm bearing 6x24	–	–	A5005-00-N03
16	Extension 240 mm	–	–	S4003-02-N03
17	Cover of top sash hinge	–	–	A7004-10-N*
18	Cover of stay arm bearing	–	–	A7005-10-N*
19	Cover of the drill-in corner hinge	–	–	A7006-10-N*
19a	Cover of rebate corner hinge, left / right	–	–	A7009-00-L/R**
20	Top cover of corner bearing	–	–	A7008-10-N*
21	Bottom cover of corner bearing	–	–	A7007-10-N*
22	Turn stay arm 12/20-13 left	280-1200	–	S5001-13-L03
	Turn stay arm 12/20-13 right	280-1200	–	S5001-13-R03
	Turn stay arm 12/20-9 left	280-1200	–	S5001-09-L03
	Turn stay arm 12/20-9 right	280-1200	–	S5001-09-R03
23	Optional micro ventilation for gear	–	950-2390	S7001-00-N03
24	Double sash lever espagnolette variable 1 L=450, 551-750	–	551-750	S1002-05-N03
	Double sash lever espagnolette variable 2 L=650, 751-950	–	751-950	S1002-07-N03
	Double sash lever espagnolette variable 3 L=1130, 951-1430	–	951-1430	S1002-12-N03
	Double sash lever espagnolette variable 4 L=1610, 1431-1910	–	1431-1910	S1002-17-N03
	Double sash lever espagnolette variable 5 L=2090, 1911-2390	–	1911-2390	S1002-22-N03
25	Concealed middle hinge sash part	–	–	A7056-00-N03
26	Concealed middle hinge, frame part	–	–	A7057-**-N03
27	Locking plate, integrated slit	–	–	***
28a	Locking plate for adjustable integrated slit for double sash	–	–	S6009-00-N03
29	Balcony catch for double-sash gear	–	–	A7019-00-N03
29a	Balcony locking pin	–	–	A7031-00-N00
32	Middle hinge with cover	–	–	A7045-00-N03
33	Middle hinge	–	–	A7030-**-N03

* - for decorative covers in other colors look at p. 28

** according to displacement axis of sash groove (9 mm, 10 mm, 13 mm, 14 mm)

*** look at the section "Profile-depending elements" or "Hinges group" of SMART LINE S+ technical catalogue



Section 6 ▶ Hardware set combinations

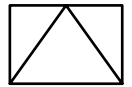

■ System S+. Tilt set. Basic security

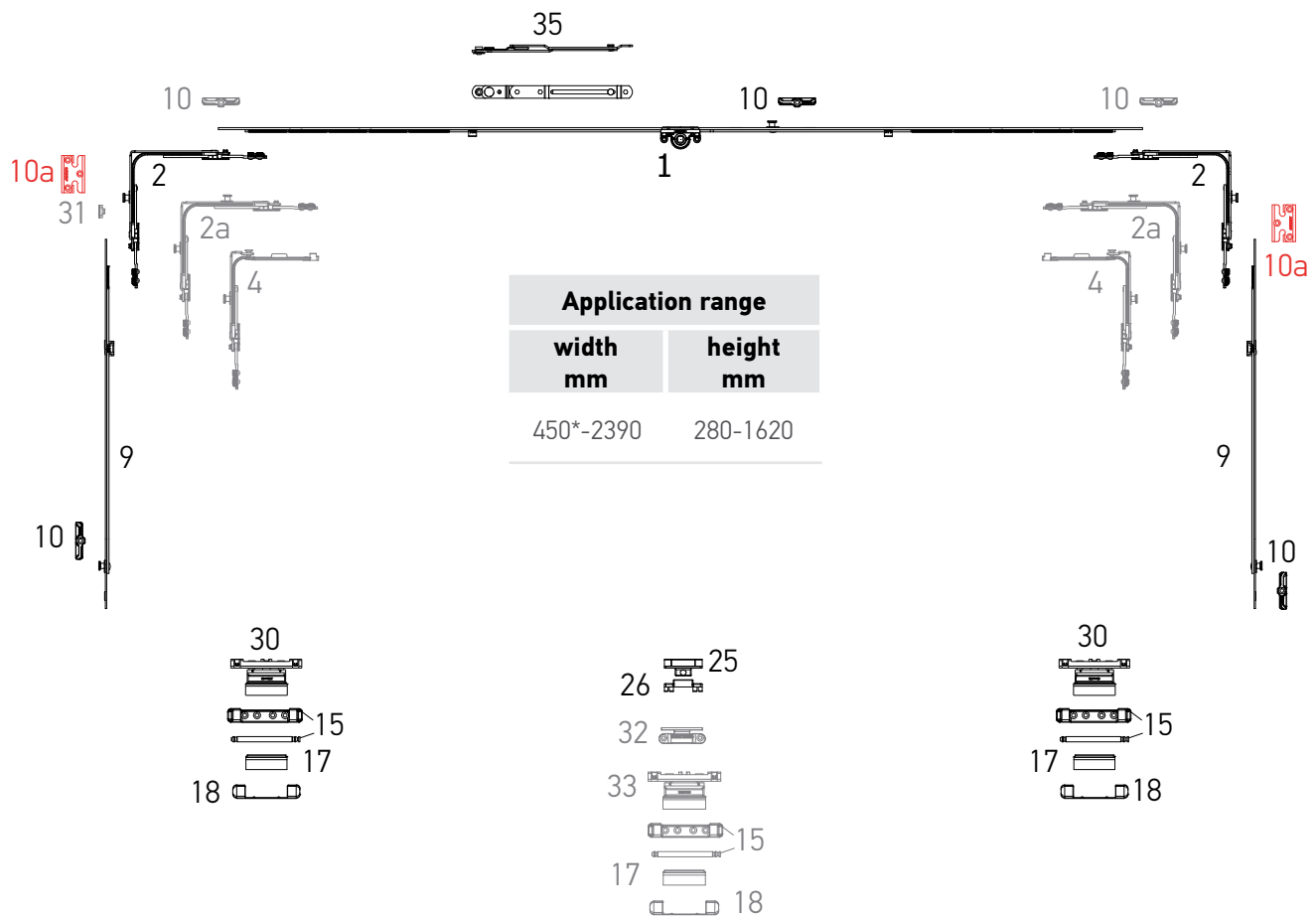

* stay arm should be installed vertically



Section 6 ▶ Hardware set combinations

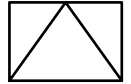

■ **System S+.**
Tilt set. Security level 1

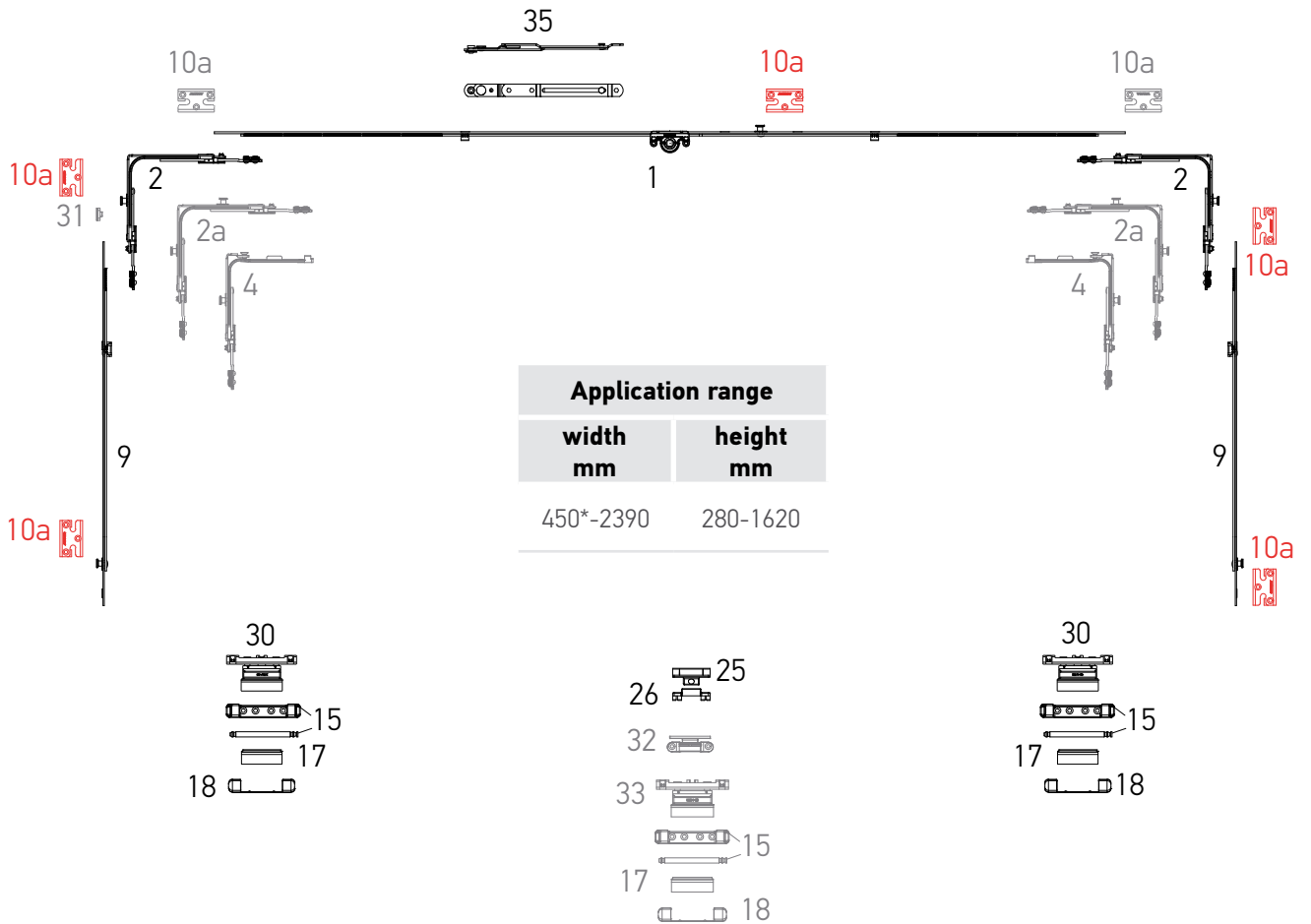

* stay arm should be installed vertically

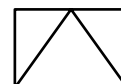
Section 6 ▶ Hardware set combinations

■ System S+.
Tilt set

Nº	Description	Application range by width	Application range by height	Part No.
1	Gear variable 1, L=520, 551-750	–	551-750	S1001-04-N03
	Gear variable 2, L=1000, 751-1230, 1 ML	–	751-1230	S1001-09-N03
	Gear variable 3, L=1200, 950-1430, 1 ML	–	950-1430	S1001-11-N03
	Gear variable 4, L=1480, 1231-1710, 2 ML	–	1231-1710	S1001-15-N03
	Gear variable 5, L=1680, 1431-1910, 2 ML	–	1431-1910	S1001-16-N03
	Gear variable 6, L=2160, 1911-2390, 3 ML	–	1911-2390	S1001-21-N03
2	Corner transmission standard	400-1280	450-2390	S2001-00-N03
2a	Corner transmission, 2ML	400-1280	450-2390	S2002-00-N03
4	Corner transmission s	280-1280	450-2390	S2003-00-N03
		350-520	290-350	S2003-00-N03
9	Middle lock extension L=480	800-1230	–	S4002-05-N03
	Middle lock extension L=880	1231-1620	–	S4002-09-N03
10	Locking plate	–	–	***
10a	Locking plate safety	–	–	***
15	Stay arm bearing 3x3	–	–	A5001-00-N03
15a	Stay arm bearing 6x24	–	–	A5005-00-N03
17	Cover of top sash hinge	–	–	A7004-10-N*
18	Cover of stay arm bearing	–	–	A7005-10-N*
25	Concealed middle hinge sash part	–	–	A7056-00-N03
26	Concealed middle hinge frame part	–	–	A7057-**-N03
30	Bottom hinges for tilt sash	–	–	A7014-**-N03
31	Stroke limiter 90°	–	–	A7052-00-N03
32	Middle hinge with cover	–	–	A7045-00-N01;N02
33	Middle hinge	–	–	A7030-**-N03
35	Tilt stay arm	–	–	A7017-00-N03

* - for decorative covers in other colors look at p. 28

** according to displacement axis of sash groove (9 mm, 10 mm, 13 mm, 14 mm)

*** look at the section "Profile-depending elements" or "Hinges group" of SMART LINE S+ technical catalogue

Section 6 ▶ Hardware set combinations

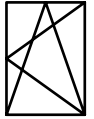

System S+.
Tilt and turn set. Basic security
for aluminum profile

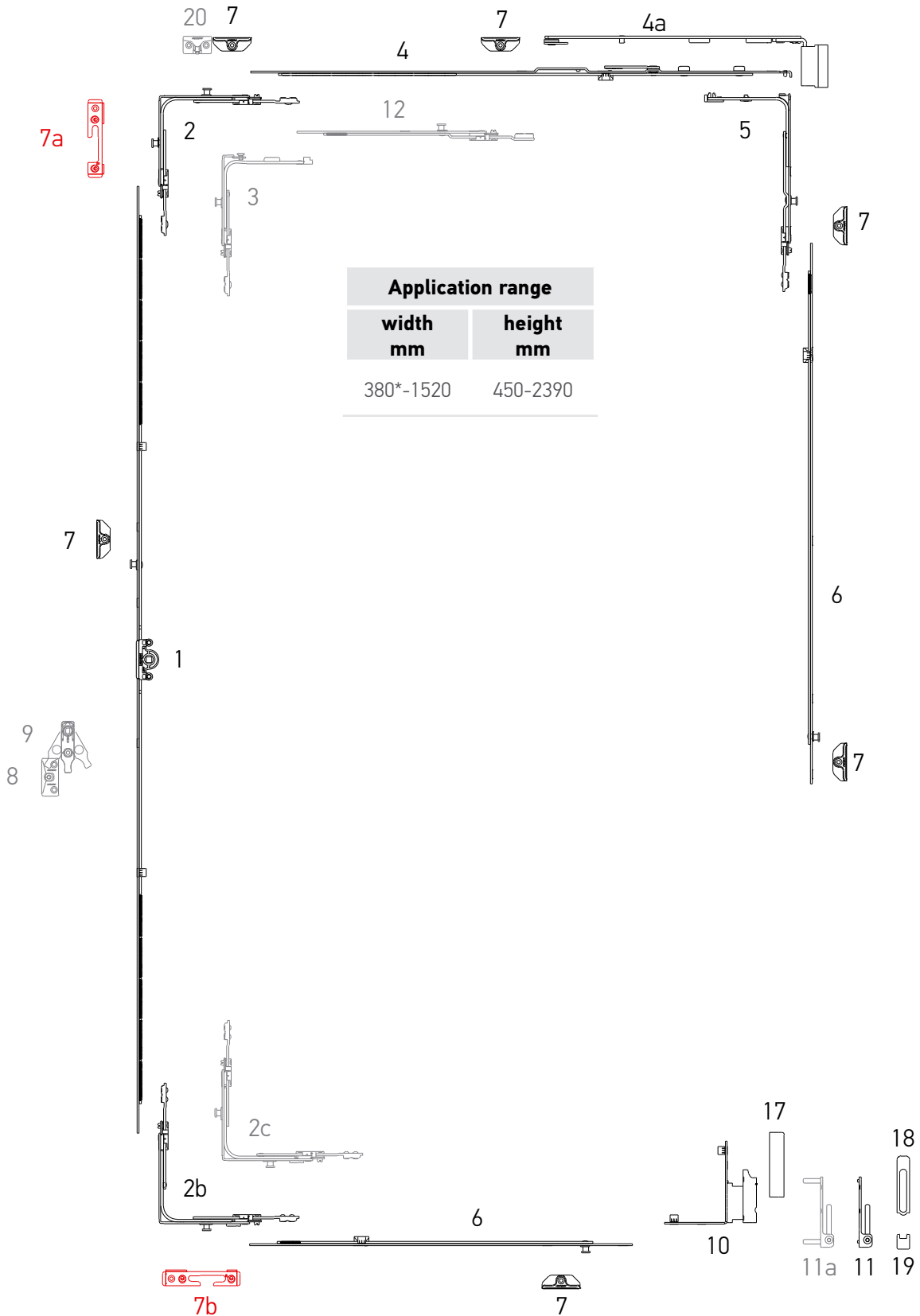

* with corner transmission s



Section 6 ▶ Hardware set combinations

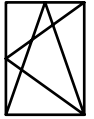

■ **System S+.**
Tilt and turn set. Security level 1
for aluminum profile

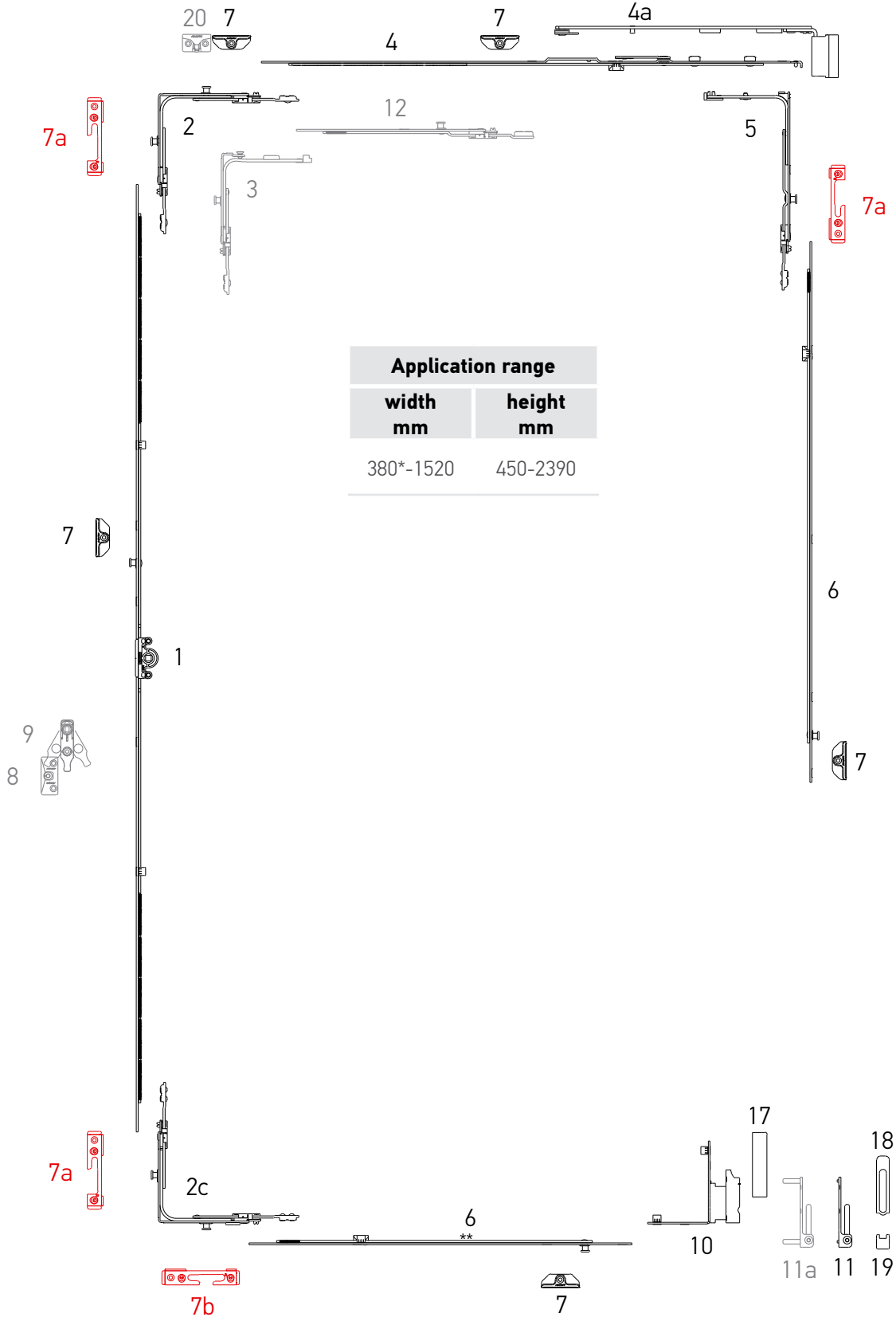

* with corner transmission s

Section 6 ▶ Hardware set combinations

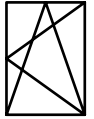

System S+.
Tilt and turn set. Security level 2
for aluminum profile

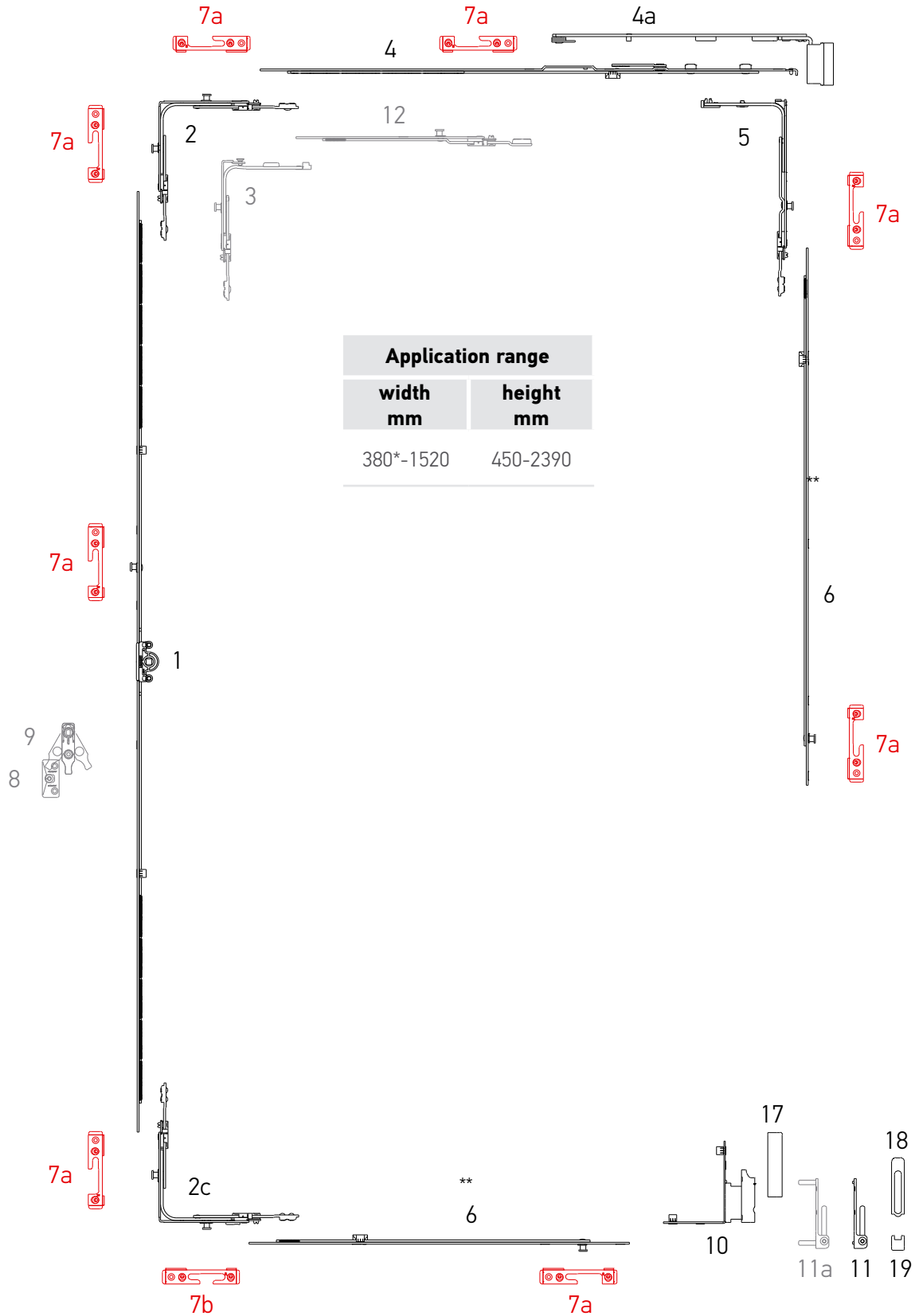

* with corner transmission s

Section 6 ▶ Hardware set combinations

■ System S+.
Tilt and turn set for aluminum profile

Nº	Description	Application range by width	Application range by height	Part No.
1	Gear variable 0, L=320, 450-550	–	450-550	S1001-02-N03
	Gear variable 1, L=520, 551-750	–	551-750	S1001-04-N03
	Gear variable 2, L=1000, 751-1230, 1 ML	–	751-1230	S1001-09-N03
	Gear variable 3, L=1200, 950-1430, 1 ML	–	950-1430	S1001-11-N03
	Gear variable 4, L=1480, 1231-1710, 2 ML	–	1231-1710	S1001-15-N03
	Gear variable 5, L=1680, 1431-1910, 2 ML	–	1431-1910	S1001-16-N03
	Gear variable 6, L=2160, 1911-2390, 3 ML	–	1911-2390	S1001-21-N03
2	Corner transmission, 2ML	400-1280	450-2390	S2002-00-N03
2b	Corner transmission, bottom	400-1280	450-2390	S2006-00-N03
2c	Corner transmission, 2ML, bottom	400-1280	450-2390	S2007-00-N03
3	Corner transmission s	280-1280	450-2390	S2003-00-N03
		330-520	290-350	
4	Stay arm connecting plate 1 L=485, 400-600	400-600	–	S3003-05-N03
	Stay arm connecting plate 2 L=685, 601-800	601-800	–	S3003-07-N03
	Stay arm connecting plate 3 L=925, 801-1040	801-1040	–	S3003-09-N03
	Stay arm connecting plate 4 L=1165, 1041-1280	1041-1280	–	S3003-12-N03
4a	Stay arm 9, L=248, 400-600, left	400-600	–	S3002-02-L03
	Stay arm 9, L=248, 400-600, right	400-600	–	S3002-02-R03
	Stay arm 9, L = 319, 601-800, left	601-800	–	S3002-03-L03
	Stay arm 9, L = 319, 601-800, right	601-800	–	S3002-03-R03
	Stay arm 9, L = 449, 801-1040, left	801-1040	–	S3002-04-L03
	Stay arm 9, L = 449, 801-1040, right	801-1040	–	S3002-04-R03
	Stay arm 9, L = 539, 1041-1280, left	1041-1280	–	S3002-05-L03
	Stay arm 9, L = 539, 1041-1280, right	1041-1280	–	S3002-05-R03
5	Middle lock vertical	–	450-850	S4001-00-N03
6	Middle lock extension L=480	800-1230	851-1230	S4002-05-N03
	Middle lock extension L=680	–	1231-1430	S4002-07-N03
	Middle lock extension L=880	1231-1620	1431-1710	S4002-09-N03
	Middle lock extension L=1040	–	1711-1910	S4002-10-N03
	Middle lock extension L=1530	–	1911-2390	S4002-15-N03
7	Locking plate for aluminum system, 9 mm	–	–	A7070-09-N03
7a	Safety locking plate for aluminum system, 9 mm, left / right	–	–	S6118-09-L/R03
7b	Tilt safety locking plate for aluminum system, 9 mm, left / right	–	–	S6120-09-L/R03
8	Lifting plate	–	–	A6028-09-N03
9	Wrong operation safety device with sash lifter	–	751-2390	A7001-00-N03

Section 6 ▶ Hardware set combinations

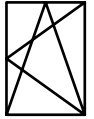

■ **System S+.**

Tilt and turn set for aluminum profile

Nº	Description	Application range by width	Application range by height	Part No.
10	Rebate corner hinge 20/9 left	-	-	A5009-09-L03
	Rebate corner hinge 20/9 right	-	-	A5009-09-R03
	Rebate corner hinge 18/9 left	-	-	A5010-09-L03
	Rebate corner hinge 18/9 right	-	-	A5010-09-R03
11	Corner bearing 3x3	-	-	A5002-00-N03
11a	Corner bearing 6x22	-	-	A5004-00-N03
12	Extension 240 mm	-	-	S4003-02-N03
17	Cover of rebate corner hinge	-	-	A7085-00-L/R*
18	Top cover of corner bearing	-	-	A7008-10-N*
19	Bottom cover of corner bearing	-	-	A7007-10-N*
20	Locking plate, integrated slit	-	-	A6026-09-N03

* - for decorative covers in other colors look at p. 28

Section 6 ▶ Hardware set combinations

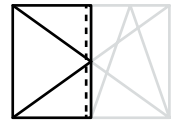

■ **System S+.**

Double sash. Secondary sash of double-sash window. Basic security for aluminum profile

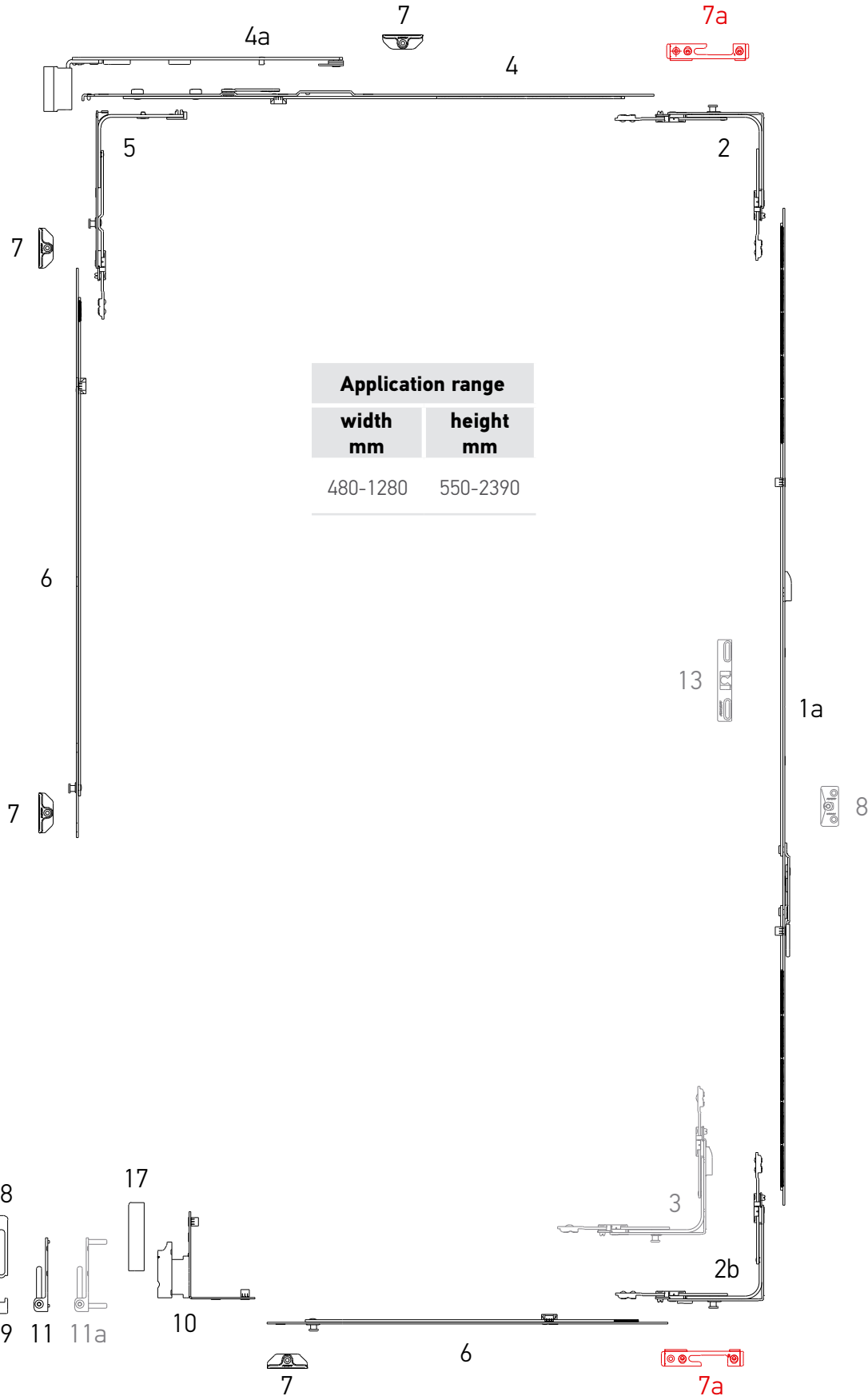

Section 6 ▶ Hardware set combinations

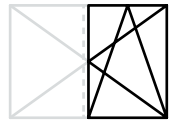

■ **System S+.**
Double sash. Main sash. Basic security
for aluminum profile

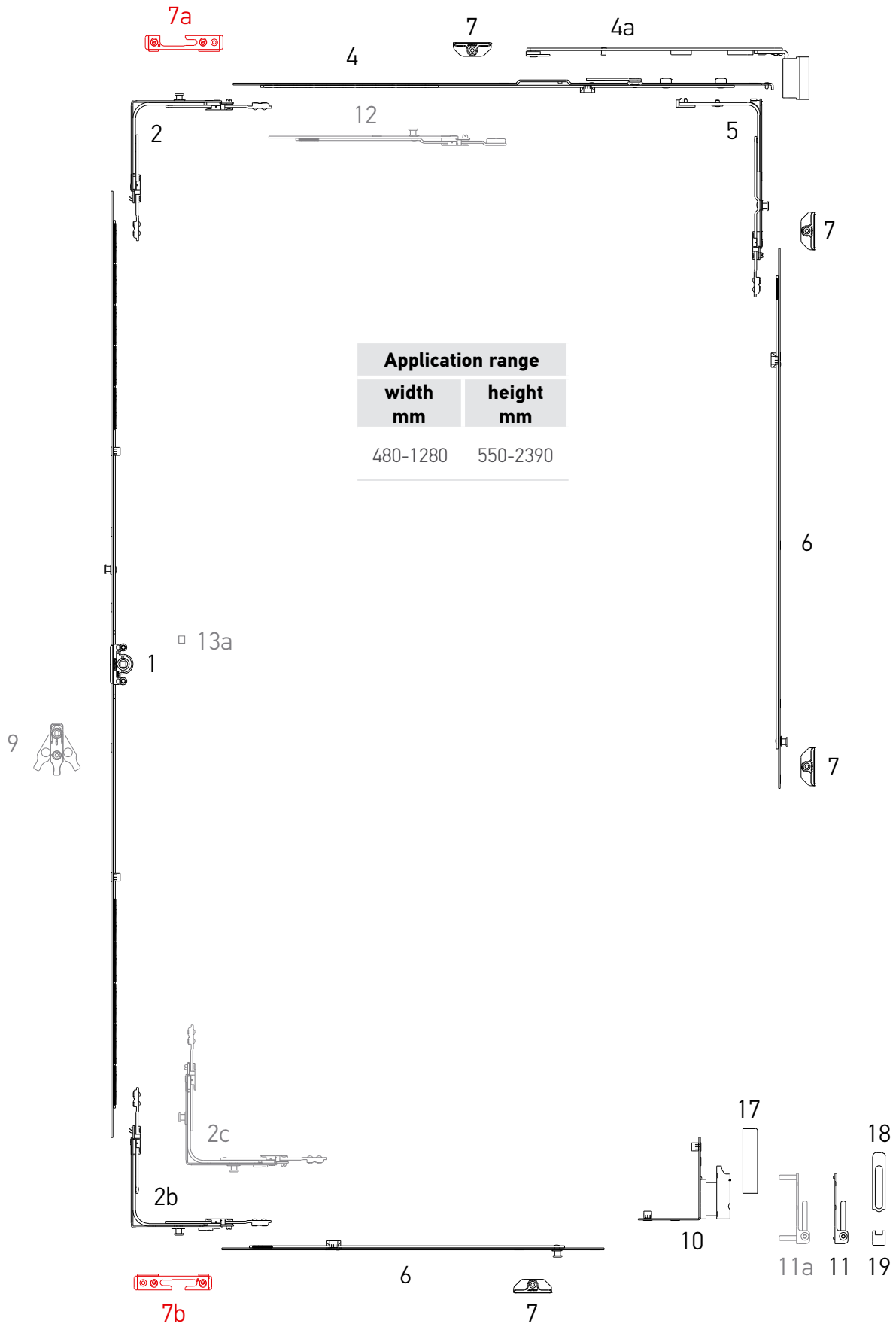

Section 6 ▶ Hardware set combinations

■ System S+. Double sash for aluminum profile

Nº	Description	Application range by width	Application range by height	Part No.
1	Gear variable 1, L=520, 551-750	-	551-750	S1001-04-N03
	Gear variable 2, L=1000, 751-1230, 1 ML	-	751-1230	S1001-09-N03
	Gear variable 3, L=1200, 950-1430, 1 ML	-	950-1430	S1001-11-N03
	Gear variable 5, L=1680, 1431-1910, 2 ML	-	1431-1910	S1001-16-N03
	Gear variable 6, L=2160, 1911-2390, 3 ML	-	1911-2390	S1001-21-N03
1a	Double sash lever espagnolette variable 1 L=450, 551-750	-	551-750	S1002-05-N03
	Double sash lever espagnolette variable 2 L=650, 751-950	-	751-950	S1002-07-N03
	Double sash lever espagnolette variable 3 L=1130, 951-1430	-	951-1430	S1002-12-N03
	Double sash lever espagnolette variable 4 L=1610, 1431-1910	-	1431-1910	S1002-17-N03
	Double sash lever espagnolette variable 5 L=2090, 1911-2390	-	1911-2390	S1002-22-N03
2	Corner transmission standard	400-1280	450-2390	S2001-00-N03
2b	Corner transmission, bottom	400-1280	450-2390	S2006-00-N03
2c	Corner transmission, 2ML, bottom	400-1280	450-2390	S2007-00-N03
3	Corner transmission, double sash	400-1280	550-2390	S2005-00-N03
4	Stay arm connecting plate 1 L=485, 400-600	400-600	-	S3003-05-N03
	Stay arm connecting plate 2 L=685, 601-800	601-800	-	S3003-07-N03
	Stay arm connecting plate 3 L=925, 801-1040	801-1040	-	S3003-09-N03
	Stay arm connecting plate 4 L=1165, 1041-1280	1041-1280	-	S3003-12-N03
4a	Stay arm 9, L=248, 400-600, left	400-600	-	S3002-02-L03
	Stay arm 9, L=248, 400-600, right	400-600	-	S3002-02-R03
	Stay arm 9, L = 319, 601-800, left	601-800	-	S3002-03-L03
	Stay arm 9, L = 319, 601-800, right	601-800	-	S3002-03-R03
	Stay arm 9, L = 449, 801-1040, left	801-1040	-	S3002-04-L03
	Stay arm 9, L = 449, 801-1040, right	801-1040	-	S3002-04-R03
	Stay arm 9, L = 539, 1041-1280, left	1041-1280	-	S3002-05-L03
	Stay arm 9, L = 539, 1041-1280, right	1041-1280	-	S3002-05-R03
5	Middle lock vertical	-	551-850	S4001-00-N03
6	Middle lock extension L=480	800-1230	850-1230	S4002-05-N03
	Middle lock extension L=680	-	1231-1430	S4002-07-N03
	Middle lock extension L=880	1231-1620	1431-1710	S4002-09-N03
	Middle lock extension L=1040	-	1711-1910	S4002-10-N03
	Middle lock extension L=1530	-	1911-2390	S4002-15-N03
7	Locking plate for aluminum system, 9 mm	-	-	A7070-09-N03
7a	Safety locking plate for aluminum system, 9 mm, left / right	-	-	S6118-09-L/R03
7b	Tilt safety locking plate for aluminum system, 9 mm, left / right	-	-	S6120-09-L/R03
8	Lifting plate, double sash	-	751-2390	A6028-09-N03
9	Wrong operation safety device with sash lifter	-	751-2390	A7001-00-N03

Section 6 ▶ Hardware set combinations

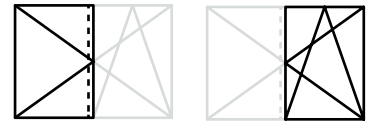
■ System S+. Double sash for aluminum profile

Nº	Description	Application range by width	Application range by height	Part No.
10	Rebate corner hinge 20/9 left	–	–	A5009-09-L03
	Rebate corner hinge 20/9 right	–	–	A5009-09-R03
	Rebate corner hinge 18/9 left	–	–	A5010-09-L03
	Rebate corner hinge 18/9 right	–	–	A5010-09-R03
11	Corner bearing 3x3	–	–	A5002-00-N03
11a	Corner bearing 6x24	–	–	A5004-00-N03
12	Extension 240 mm	–	–	S4003-02-N03
13	Balcony catch for double-sash gear	–	–	A7047-00-N03
13a	Balcony locking pin	–	–	A7031-00-N00
17	Cover of rebate corner hinge	–	–	A7085-00-L/R*
18	Top cover of corner bearing	–	–	A7008-10-N*
19	Bottom cover of corner bearing	–	–	A7007-10-N*

* - for decorative covers in other colors look at p. 28

SMART LINE **S+**

[7]

Tools / Instalation / Adjustments

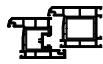

Section 7 ▶ Tools / Instalation/ Adjustments

■ **Locking plate jigs**

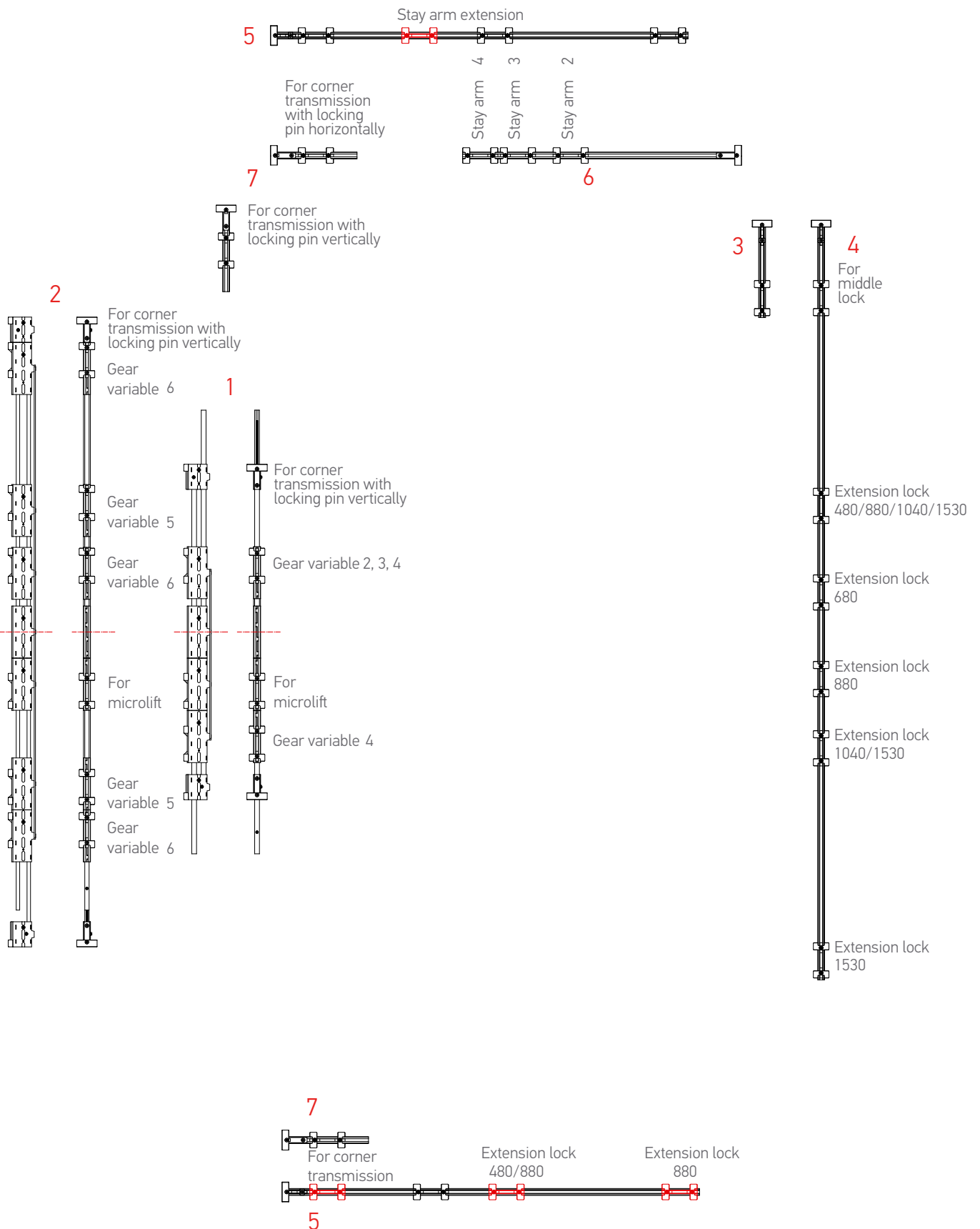

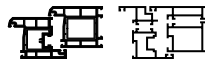
Section 7 ▶ Tools / Instalation/ Adjustments

■ Locking plate jigs

Nº	Description	Designation	Part No.
1	Telescopic jig GV 1	For tilt-and-turn gear 2, 3, 4. The handle is positioned in center	A7024-01-N00
2	Telescopic jig GV 2	For tilt-and-turn gear 5, 6. The handle is positioned in center.	A7024-02-N00
3	Linear jig ML	For middle lock.	A7049-00-N00
4	Linear jig EV	For all vertical middle lock extensions.	A7050-00-N00
5	Linear jig EH	For gorizontal extensions L=480 and L=880.	A7051-00-N00
6	Linear jig SA	For stay-arms of all sizes	A7032-00-N00
7	Linear jig CT	For corner transmission	A7025-00-N00



Section 7 ▶ Tools / Instalation/ Adjustments

Information for an adjustment of jigs

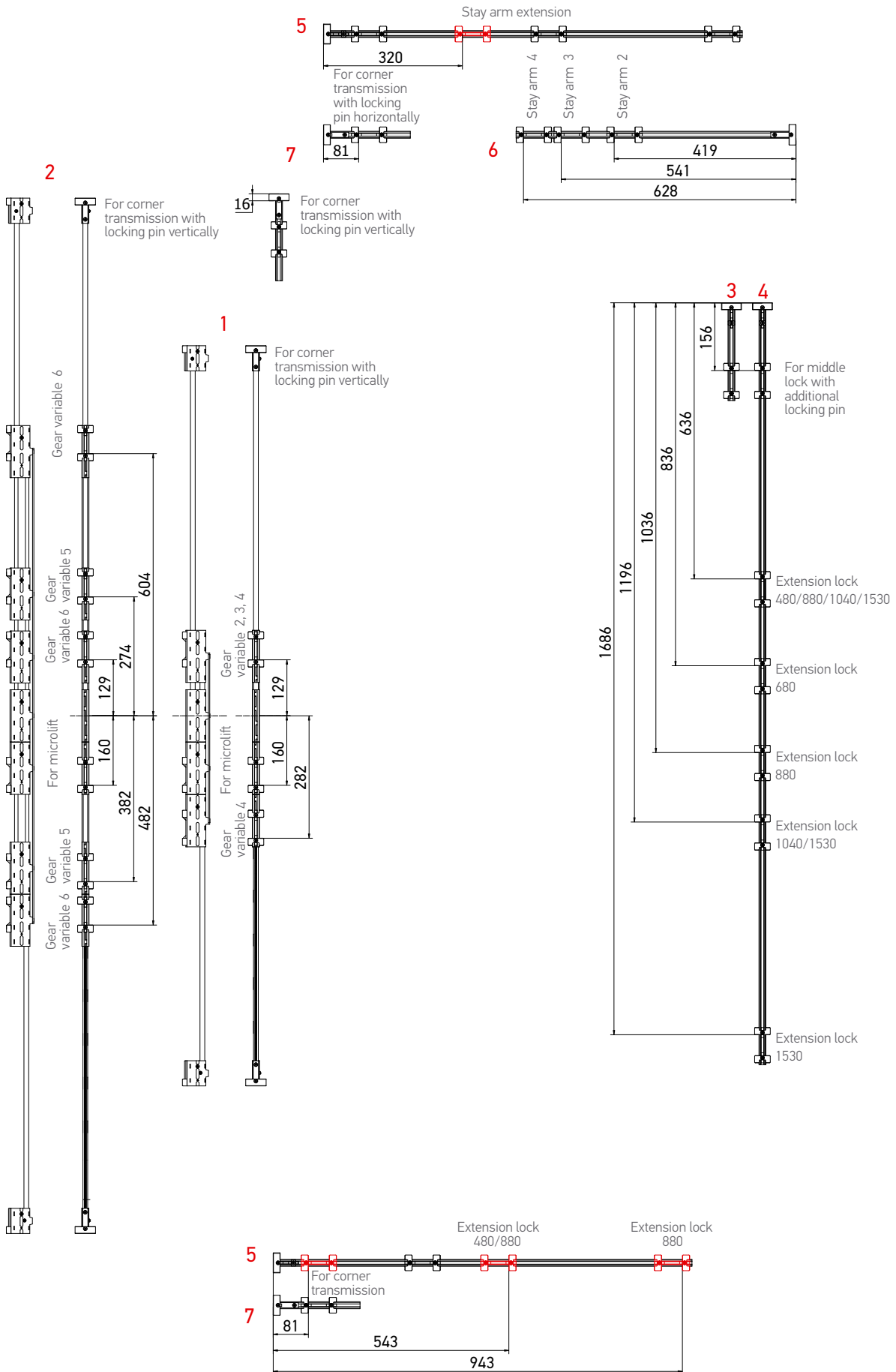

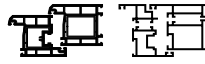

Section 7 ▶ Tools / Instalation/ Adjustments

■ Locking plate jigs

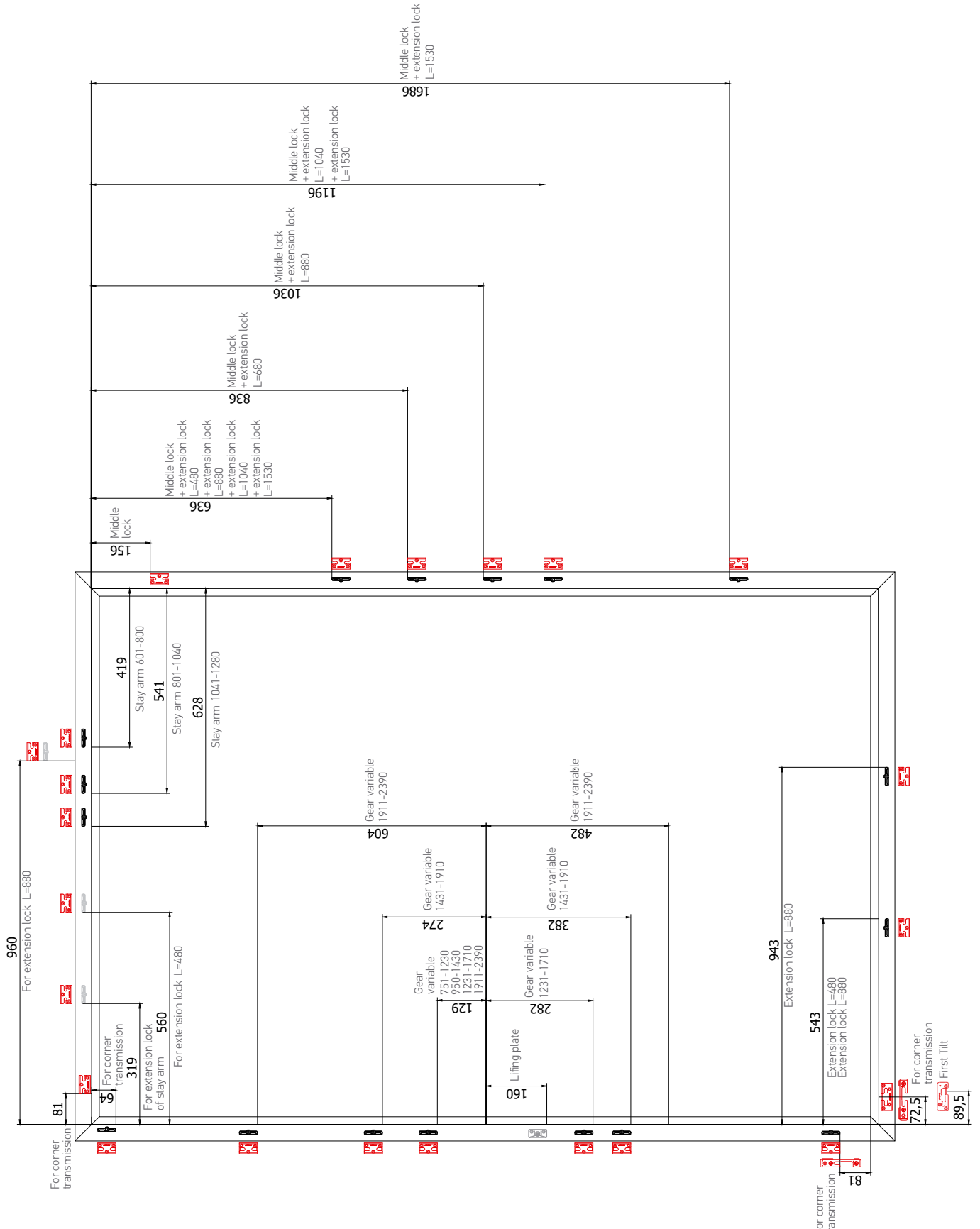

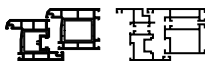

Section 7 ▶ Tools / Instalation/ Adjustments

■ Locking plate jigs (constant gear)

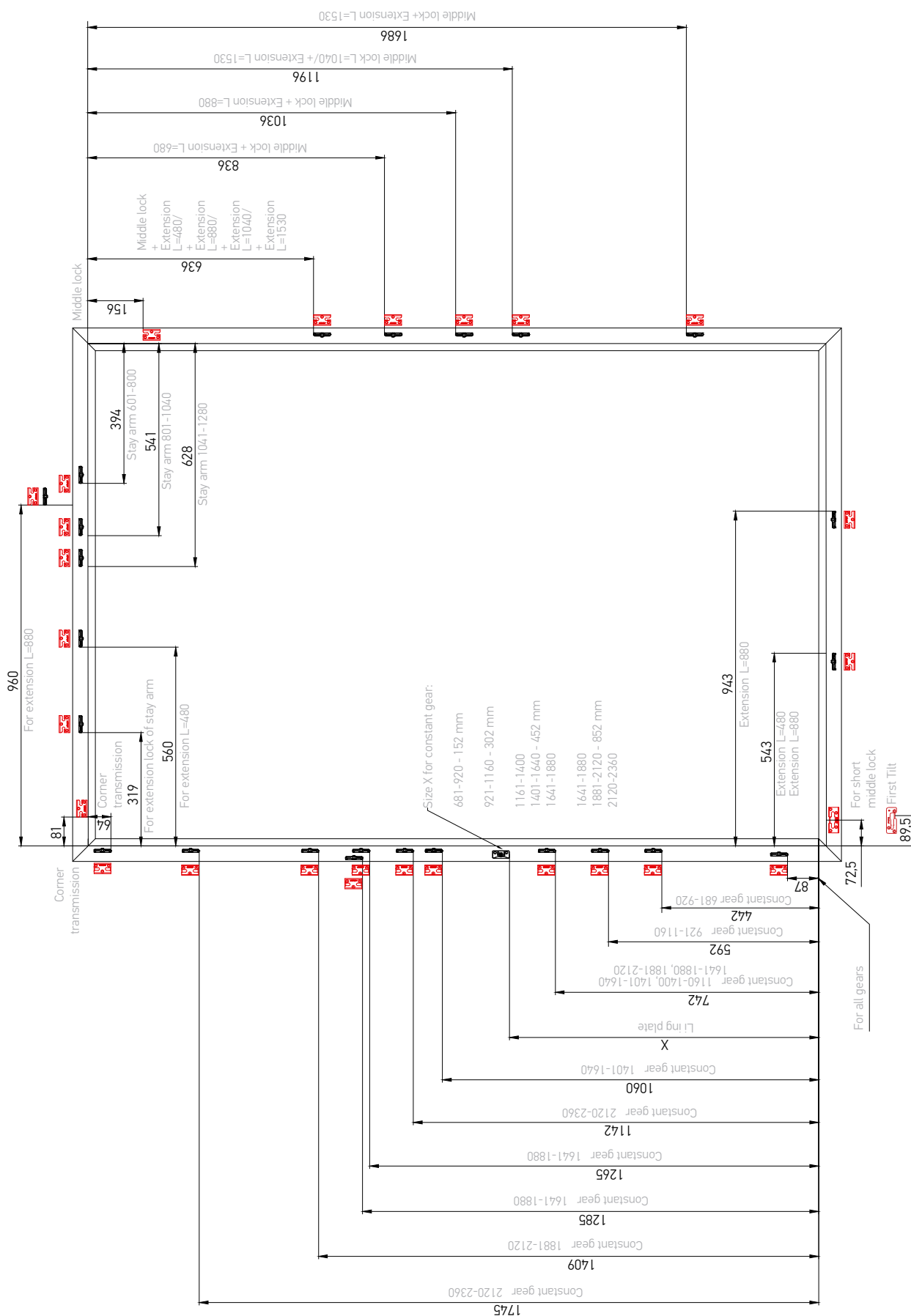

Section 7 ▶ Tools / Instalation/ Adjustments

■ **Drilling jig for frame hinges**

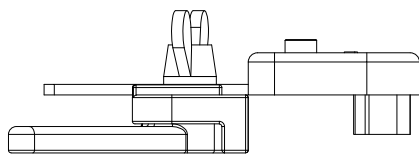
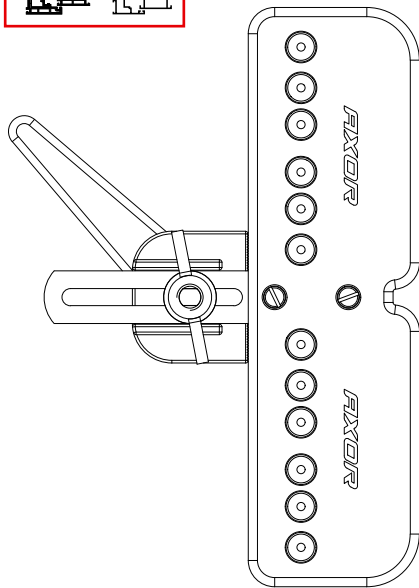
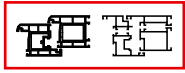

■ **Drilling jig for sash hinges**

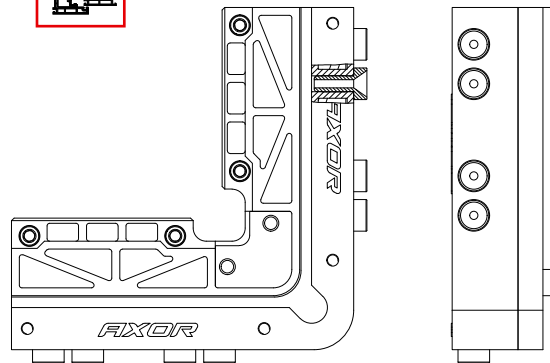

■ **Adjustment plate**



Description	Profile	Designation			Part No.
Drilling jig for frame hinges	12/20-13	For drilling holes for top and bottom frame hinges	drill Ø3	50	A7002-00-N09
Drilling jig for frame hinges	12/21-13	For drilling holes for top and bottom frame hinges	drill Ø3	50	A7002-20-N09
Drilling jig for sash hinges	12/20-13; 12/20-9	For drilling holes for bottom sash hinge	drill Ø3	80	A7003-00-N09
Drilling jig for sash hinges	12/21-13; 12/21-9	For drilling holes for bottom sash hinge	drill Ø3	80	A7003-20-N09
Adjustment plate 0,5 mm	—	For sash jig adjustment	—	1	10073-05-N08
Adjustment plate 1 mm	—	For sash jig adjustment	—	1	10073-10-N08

Section 7 ▶ Tools / Instalation/ Adjustments

■ **Drilling jig for frame hinges 130 kg**

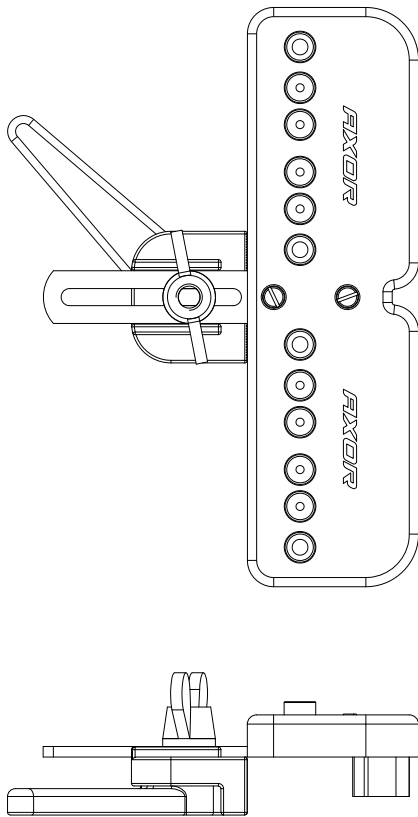

■ **Drilling jig for sash hinges 130 kg**

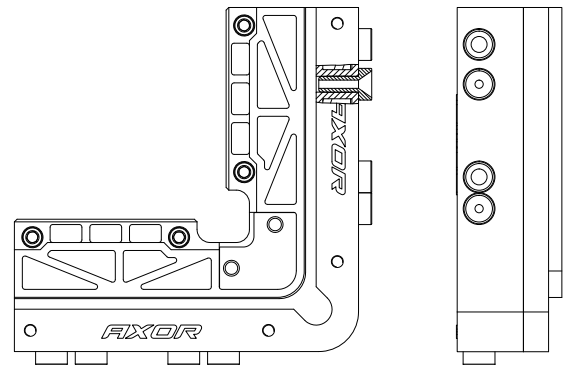

■ **Adjustment plate**



Description	Profile	Designation			Part No.
Drilling jig for frame hinges 130 kg	12/20-13	For drilling holes for top and bottom frame hinges	drill Ø3/6	50	A7002-10-N09
Drilling jig for frame hinges 130 kg	12/21-13	For drilling holes for top and bottom frame hinges	drill Ø3/6	50	A7002-30-N09
Drilling jig for sash hinges 130 kg	12/20-13; 12/20-9-	For drilling holes for bottom sash hinge	drill Ø3/6	80	A7003-10-N09
Drilling jig for sash hinges 130 kg	12/20-13; 12/21-9-	For drilling holes for bottom sash hinge	drill Ø3/6	80	A7003-30-N09
Adjustment plate 0,5 mm	—	For sash jig adjustment	—	1	10073-05-N08
Adjustment plate 1 mm	—	For sash jig adjustment	—	1	10073-10-N08

Section 7 ▶ Tools / Instalation/ Adjustments

■ **Aluminum drilling jig for frame top hinge, oblique window**

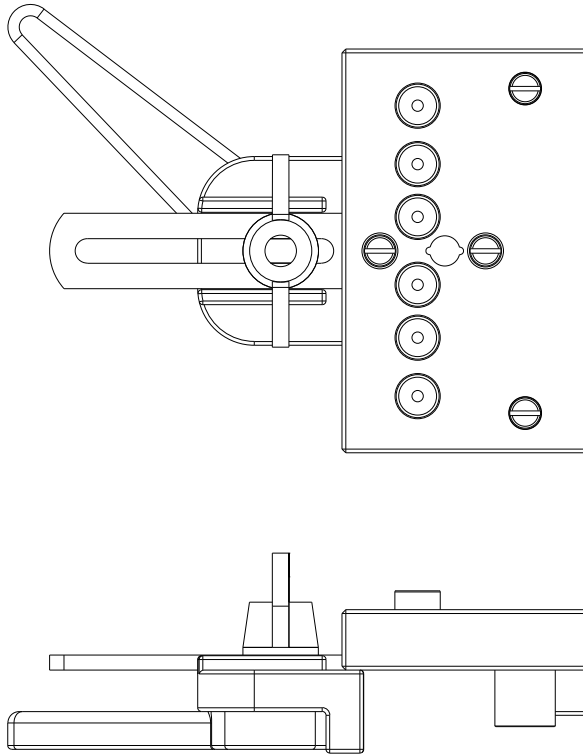

Description	Profile	Designation			Part No.
Aluminum drilling jig for frame top hinge, oblique window	12/20-13; 12/20-9	For drilling holes for top hinge, oblique window	drill Ø3	1	A7002-50-N03

Section 7 ▶ Tools / Instalation/ Adjustments

■ **Allen key U type**

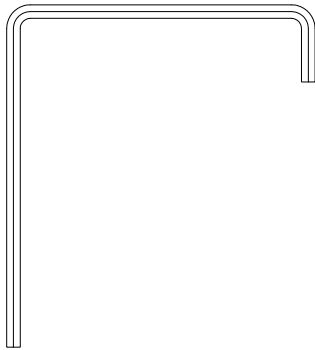

■ **Allen key (L type plastic coated)**

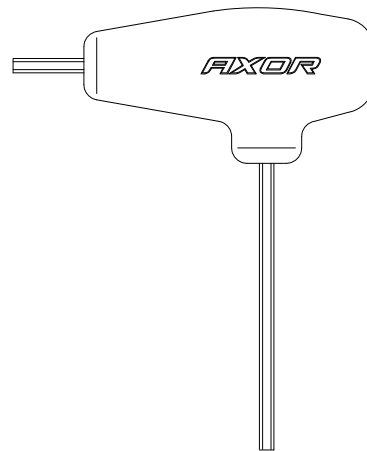

■ **Mounting square handle**

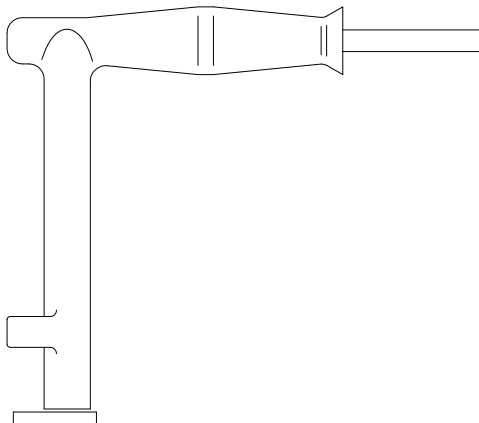

Description	Product group		Part No.
Allen key U type	K3-S+	100	A7020-00-N03
Allen key L type (plactic coated)	K3-S+	12	A7021-00-N03
Mounting square handle	K3-S+	1	A7022-00-N03

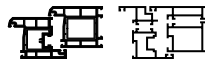

Section 7 ▶ Tools / Instalation/ Adjustments

■ Sash installation

The pin should be installed only when the sash has been closed and the handle is in "Tilt" position. Caution!

After the pin has been installed to rotate the handle to "Closed" position..

■ Sash removing

The pin should be removed only when the window has been closed and the handle is in "Tilted" position. Then, after the pin has been removed to turn the handle to "Open" position and to remove the sash.

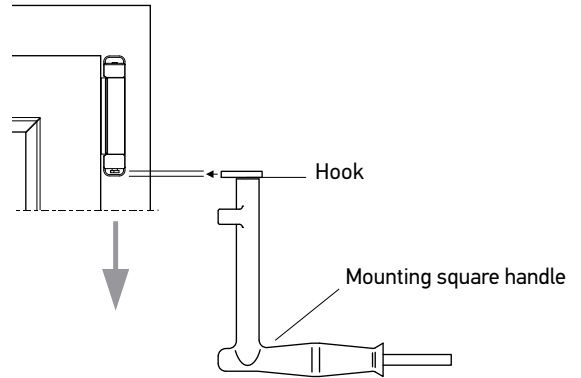
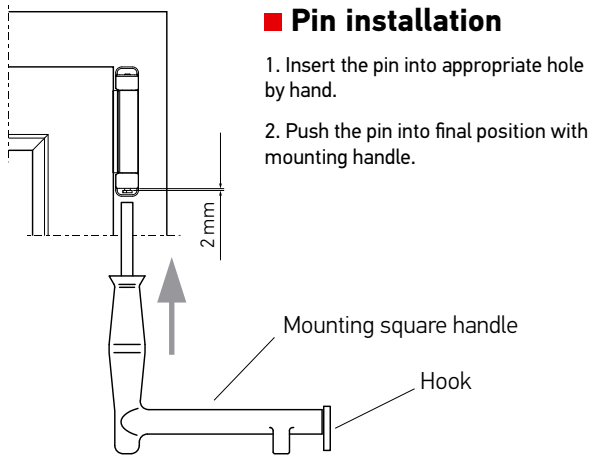

■ Stay arm

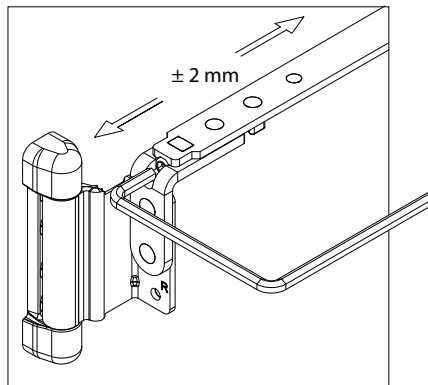
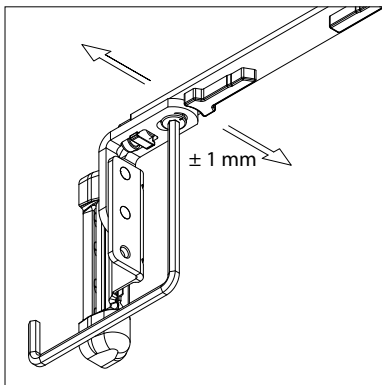

■ Drill-in corner hinge

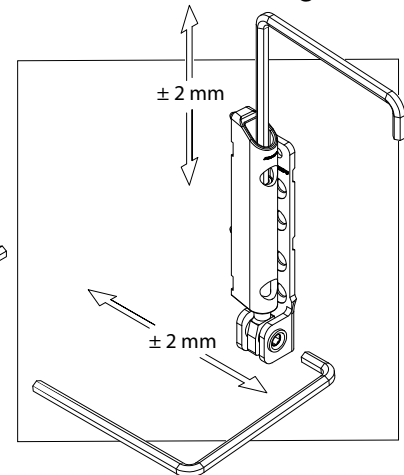

■ Turn stay arm

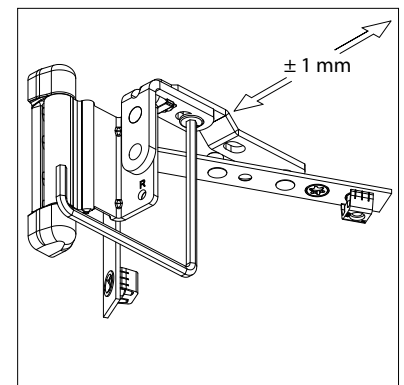
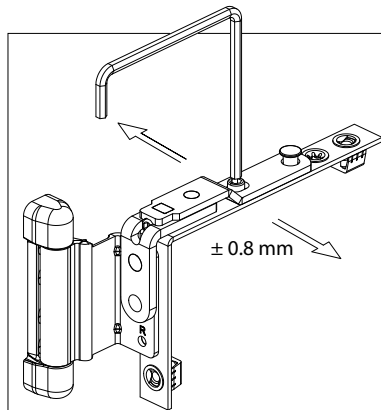
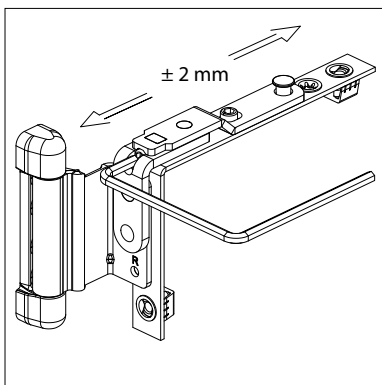

Section 7 ▶ Tools / Instalation/ Adjustments

■ **Drill-in corner hinge**

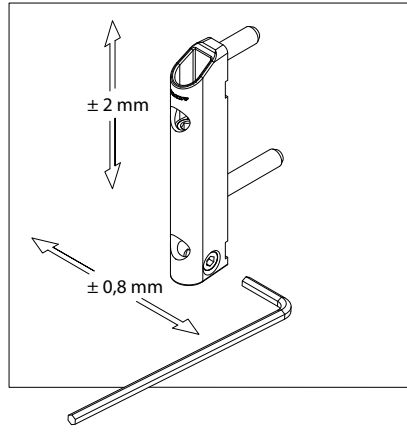
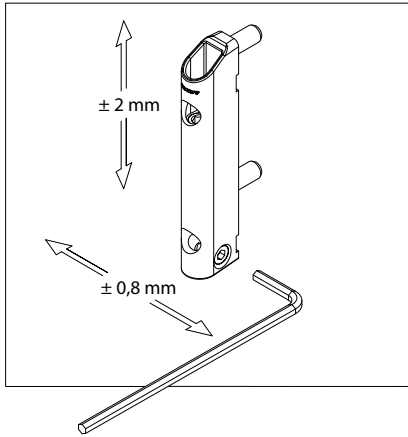

■ **Bottom hinge**

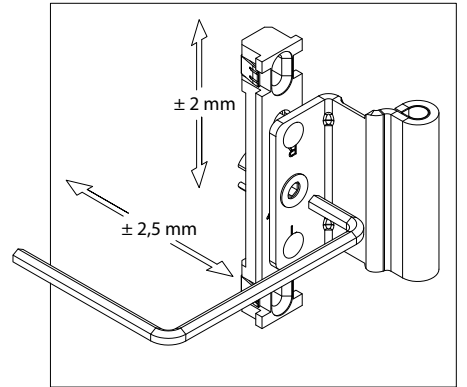

■ **Lifting plate**

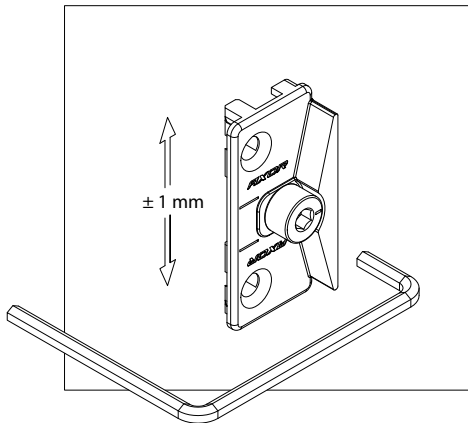

■ **Mushroom locking pin**

Locking pin	MP	Rotation direction	Adjustment limits
			± 1

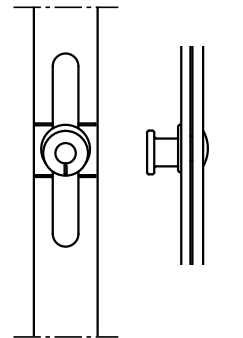

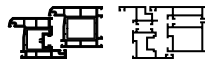

Section 7 ▶ Tools / Instalation/ Adjustments

■ **Straight cut connection**

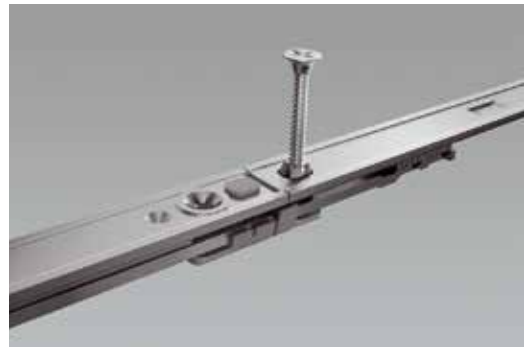
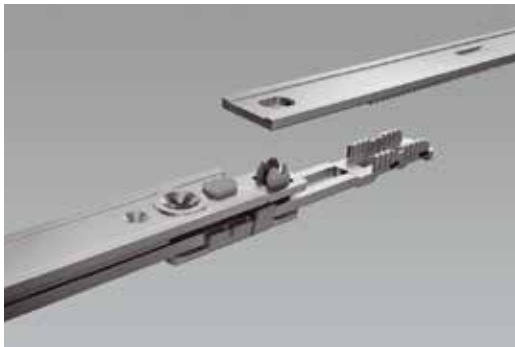

■ **Eccentric cut connection with usage of connection piece**



■ **Installation recommendations**



For hinge installation it is recommended to drill 3-mm hole in plastic and reinforcement profile, then to screw the hinge with screws without drill-bit.



Section 7 ▶ Tools / Instalation/ Adjustments

■ **Punching machines**



PS100-3-S5-GL20

- Integrated blow out function
- Eccentric cut
- Hydropneumatic drive 0,6 MPa (6 bar)..... 15 kN
- Working pressure, min..... 6 bar
- Working pressure, max..... 1 MPa (10 bar)
- Foot switch
- Designed for small up to medium size production



BSD-S5-SHGL20

- Hydropneumatic drive
- Eccentric cut
- Working pressure 6-10 bar
- Operating pressure..... 6 bar
- Matrix..... 28 kN
- Push rod..... 18 kN
- Maximum pressure 10 bar
- Foot switch

■ **The rulers**

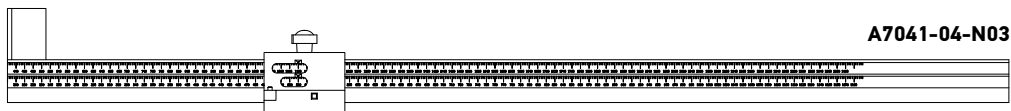

A7041-04-N03

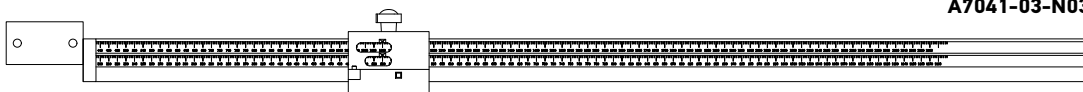

A7041-03-N03

Description	Part No.
Punching machine BSD-"S5-SHGL20, left with foot control	BSD-S5-SHGL20
Punching machine BS-Multi-MAX PS100 with foot control	PS100-3-S5-GL20
The ruler BSD-S5-SHGL20	A7041-03-N03
The ruler PS100-3-S5-GL20	A7041-04-N03



Section 7 ▶ Tools / Instalation/ Adjustments

■ **An order of the hardware installation for a frame**

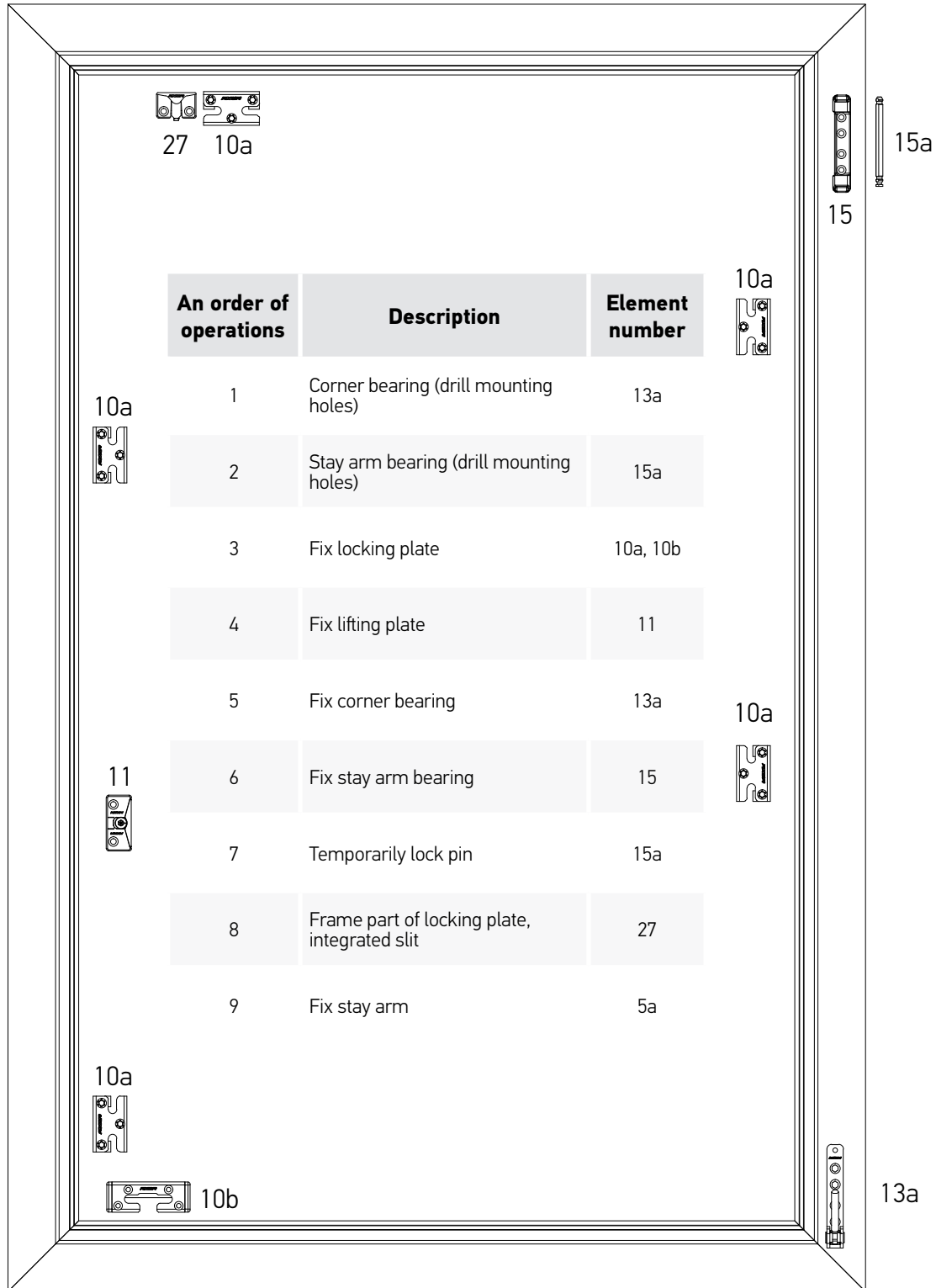



Section 7 ▶ Tools / Instalation/ Adjustments

■ **An order of the hardware installation for a sash**

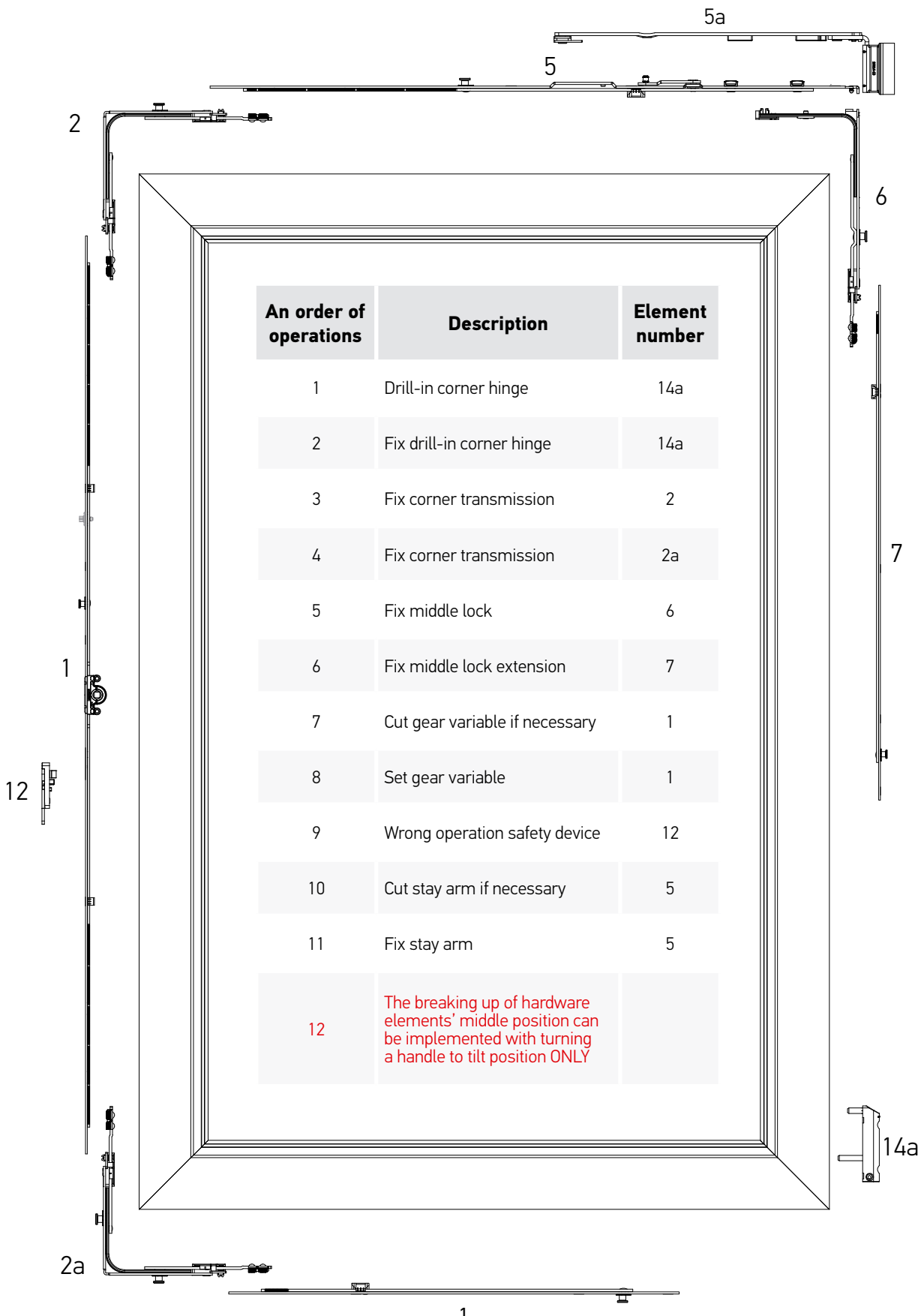

Section 7 ▶ Tools / Instalation/ Adjustments

■ **Minimum gap for mounting of visible hinges**

X - minimum gap between the groove of glazing bead and a jumb

Sash overlap, mm	X
18	26,5
20	28,5

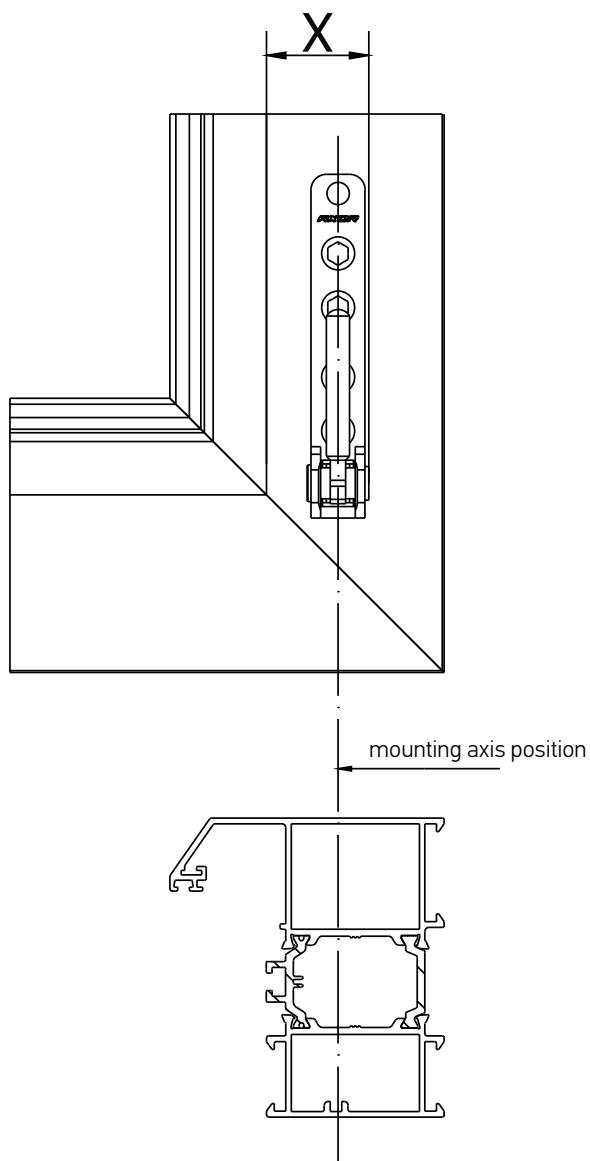

SMART LINE S+

[8]

Profile-dependent elements

Section 8 ▶ Profile-depending elements

Profile list

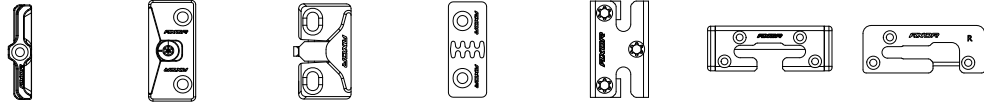

Profile's name	B	Locking plate standard	Lifting plate	Locking plate, integrated slit	Locking plate for adjustable integrated slit	Safety locking plate	Tilt locking plate safety	Tilt locking plate safety «First tilt»
ALUPLAST IDEAL 2000	13	A7012-13-N03	A6003-13-N03	A6002-13-N03	A6004-00-N03	S6001-13-N03	S6002-13-N03	
BROKELMANN 58	13	A7034-13-N00	A6003-13-N03	A6002-13-N03	A6004-00-N03	S6005-13-N03	S6006-13-N03	
BROKELMANN 70	13	A7012-13-N03	A6003-13-N03	A6002-13-N03	A6004-00-N03	S6005-13-N03	S6006-13-N03	
DECEUNINCK	13	A7044-13-N03	A6010-13-N03	A6012-13-N03		S6012-13-N03	S6013-13-N03	
GEALAN	13	A7042-13-N03	A6003-13-N03	A6002-13-N03	A6004-00-N03	S6014-13-N03	S6022-13-L/R03	
GEALAN 9000N	13	A7066-13-N03						
KBE 58/9	9	A7013-09-N03	A6007-09-N03	A6005-09-N03	A6004-00-N03	S6003-09-N03	S6004-09-N03	
KBE 58/9 Plus	9	A7043-09-N03	A6007-09-N03	A6005-09-N03	A6004-00-N03	S6003-09-N03	S6004-09-N03	
KBE 58/13	13	A7011-13-N03	A6003-13-N03	A6002-13-N03	A6004-00-N03	S6010-13-N03	S6011-13-N03	
KONING 70	13	A7012-13-N03	A6003-13-N03	A6002-13-N03	A6004-00-N03	S6005-13-N03	S6006-13-N03	
MIROPLAST WDS 400	13	A7011-13-N03	A6003-13-N03	A6002-13-N03	A6004-00-N03	S6001-13-N03	S6002-13-N03	S6015-13-L/R03
MIROPLAST WDS 404	13	A7011-13-N03	A6003-13-N03	A6002-13-N03	A6004-00-N03	S6001-13-N03	S6002-13-N03	S6015-13-L/R03
MIROPLAST WDS 505	13	A7011-13-N03	A6003-13-N03	A6002-13-N03	A6004-00-N03	S6001-13-N03	S6002-13-N03	S6015-13-L/R03
MIROPLAST WDS 800	13	A7011-13-N03	A6003-13-N03	A6002-13-N03	A6004-00-N03	S6001-13-N03	S6002-13-N03	S6015-13-L/R03
REHAU BASIC DESIGN	13	A7012-13-N03	A6003-13-N03	A6002-13-N03	A6004-00-N03	S6001-13-N03	S6002-13-N03	
REHAU BRILLANT DESIGN	13	A7012-13-N03	A6003-13-N03	A6002-13-N03	A6004-00-N03	S6001-13-N03	S6002-13-N03	S6015-13-L/R03
REHAU CLIMA DESIGN	13	A7012-13-N03	A6003-13-N03	A6002-13-N03	A6004-00-N03	S6001-13-N03	S6002-13-N03	S6015-13-L/R03
REHAU THERMO DESIGN	13	A7012-13-N03	A6003-13-N03	A6002-13-N03	A6004-00-N03	S6001-13-N03	S6002-13-N03	S6015-13-L/R03
SALAMANDER DESIGN 2D	13	A7012-13-N03	A6013-13-N03	A6014-13-N03	A6004-00-N03	S6001-13-N03	S6002-13-N03	S6015-13-L/R03
SALAMANDER DESIGN 3D	13	A7012-13-N03	A6013-13-N03	A6014-13-N03	A6004-00-N03	S6001-13-N03	S6002-13-N03	S6015-13-L/R03
VEKA SOFTLINE 58	13	A7011-13-N03	A6003-13-N03	A6002-13-N03	A6004-00-N03	S6001-13-N03	S6002-13-N03	S6015-13-L/R03
VEKA SOFTLINE 70	13	A7011-13-N03	A6003-13-N03	A6002-13-N03	A6004-00-N03	S6001-13-N03	S6002-13-N03	S6015-13-L/R03
VEKA TOPLINE AD	13	A7011-13-N03	A6003-13-N03	A6002-13-N03	A6004-00-N03	S6001-13-N03	S6002-13-N03	S6015-13-L/R03
WINTech 532 (ISOTECH)	13		A6017-13-N03	A6015-13-N03	A6016-00-N03	S6007-13-N03	S6008-13-N03	
WINTech 632	13		A6003-13-N03	A6002-13-N03	A6004-00-N03	S6001-13-N03	S6002-13-N03	S6015-13-L/R03
WINTech 742	13	A7011-13-N03	A6003-13-N03	A6002-13-N03	A6004-00-N03	S6010-13-N03	S6011-13-N03	S6015-13-L/R03
WINTech 752	13	A7011-13-N03	A6003-13-N03	A6002-13-N03	A6004-00-N03	S6010-13-N03	S6011-13-N03	S6015-13-L/R03
WINTech 80	13	A7011-13-N03	A6003-13-N03	A6002-13-N03	A6004-00-N03	S6001-13-N03	S6002-13-N03	S6015-13-L/R03

B - Sash groove position

Section 8 ▶ Profile-dependent elements

■ **Telescopic locking plate**

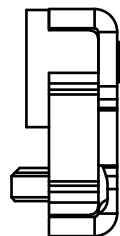
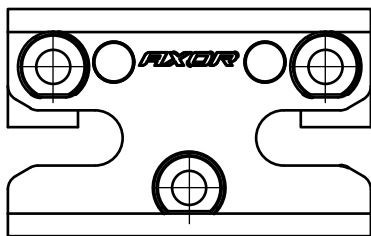
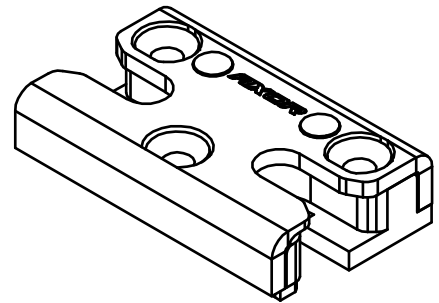
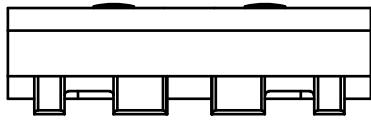

Description	Part No.
Telescopic locking plate 13 mm (WDS)	S6094-13-N03
Telescopic locking plate 13 mm (WINTECH 532)	S6095-13-N03
Telescopic locking plate 13 mm (KBE)	S6096-13-N03

Section 8 ▶ Profile-depending elements

■ Locking plates for aluminum profile

Description	Part No.
	Locking plate for aluminum system, 9 mm A7070-09-N03
	Safety locking plate for aluminum system, 9 mm, left S6118-09-L03
	Safety locking plate for aluminum system, 9 mm, right S6118-09-R03
	Tilt safety locking plate for aluminum system, 9 mm, left S6120-09-L03
	Tilt safety locking plate for aluminum system, 9 mm, right S6120-09-R03
	Tilt safety locking plate "TILT FIRST" for aluminum system, 9 mm, left S6119-09-L03
	Tilt safety locking plate "TILT FIRST" for aluminum system, 9 mm, right S6119-09-R03

SMART LINE S+



AXOR INDUSTRY
32, Truda Avenue, Dnipro,
49041, Ukraine
tel. / fax: +38-056-794-0-766
www.axorindustry.com
Designed by AXOR